



Texas Tech University – Space Raiders
Critical Design Review 2017 – 2018

Raider Aerospace Society – Space Raiders
Raider.areospace@gmail.com

Table of Contents

1. Summary	5
2. Changes since PDR	6
2.1. Vehicle	
2.2. Recovery	
2.3. Payload	
3. Vehicle Criteria	8
3.1. Design and Verification of Launch Vehicle	
3.1.1. Airframe	9
3.1.2. Fins	12
3.1.3. Nosecone	14
3.1.4. Motor Mount Assembly	17
3.1.5. Propulsion System	21
3.1.6. Bulkheads	23
3.2. Flight Predictions	24
3.2.1. Flight Profile	25
3.2.2. Simulation Data	
3.2.3. MatLab Verification	27
3.3. Subscale (Raider 1)	30
3.3.1. Fabrication / Construction	
3.3.2. Flight Predictions	31
3.3.3. Launch Report	33
3.3.4. Modeling and Scaling Factors	
3.4. Reflection	37
3.5. Recovery	
3.5.1. Final Design Specifications	
3.5.1.1. Parachutes	38
3.5.1.2. Harnesses	
3.5.1.3. Bulkheads	42
3.5.2. Final Electrical Design	50

3.5.2.1.	Altimeters	
3.5.2.2.	Ejection Charges	51
3.5.2.3.	Electronics Bay	53
3.5.2.4.	GPS Tracker	57
3.5.2.5.	Long Range Transmitter	
3.5.3.	Recovery System Performance Predictions	58
3.5.3.1.	Kinetic Energy	
3.5.3.2.	Drift	60
3.5.3.3.	Testing	63
3.5.4.	Recovery System Success Criteria	
4.	Safety	65
4.1.	Safety Procedures	
4.1.1.	Vehicle Safety	
4.1.2.	Payload Safety	66
4.1.3.	Recovery Safety	
4.1.4.	Personal Protective Equipment	67
4.2.	Reese Safety Policies	
4.3.	Safety Budget	
4.4.	Warnings and Hazards	68
4.4.1.	Recovery	
4.4.2.	Motor Preparation	71
4.4.3.	Setup on Launcher	72
4.4.4.	Igniter Installation	74
4.4.5.	Troubleshooting	75
4.4.6.	Vehicle	76
4.4.7.	Payload	78
4.5.	Section Checklist	79
5.	Payload Criteria	81
5.1.	Design Selection	
5.2.	Payload System Design	82
5.3.	Electronics	98

5.4. Justification	103
6. Project Plan	105
6.1. Testing	
6.1.1. Vehicle	
6.1.2. Recovery	
6.1.3. Payload	106
6.2. Requirements Compliance	108
6.2.1. Vehicle Requirements	
6.2.2. Recovery Compliance	111
6.2.3. Payload	112
6.2.4. Safety Requirements	114
6.3. Budget	117
6.3.1. Funding	
6.3.2. Recovery Parts List	119
6.3.3. Vehicle Parts List	
6.3.4. DACS Part List	120
6.3.5. Payload Parts List	121
6.3.6. Safety Parts List	
6.4. Timeline	122
6.4.1. Vehicle Timeline	
6.4.2. Recovery Timeline	123
6.4.3. Payload Timeline	124
7. Dynamic Apogee Control System	125
7.1. Parts	
7.1.1. Mechanism	126
7.1.2. Driver	127
7.1.3. Microcontroller / Electronics	129
7.1.4. Logic	130
7.1.5. Control Arms	131
7.1.6. Crown	133
7.1.7. Air Buffer	

7.1.8. Hinges	134
7.1.9. Flaps	135
7.1.10. Structure and Retirement	136
7.1.11. Bulkheads	137
7.2. Wind Tunnel Experiment	
Appendix A - Payload Detailed Drawings and Schematics	143
Appendix B - Guide to Building a Level One Rocket.....	182
Appendix C – Reese Technology Center Safety Protocol	202
Appendix D – Material Safety Data Sheets	206
Bibliography	214

1. Summary

Team Name: Space Raiders

Team Address: 3710 Erskine St. Apt 336, Lubbock, TX 79415

Mentors/Certification Level

- Bill Balash/L3
- Barre Wheatley/L3

Launch Vehicle Summary

Launch Vehicle Name: Raider 2

Size/Mass

- Height: 114.57in (291cm)
- Diameter: 6.73in (17.1cm)
- Mass on Pad: 42.82lbs (19425g)
- Dead Mass: 37.61lbs (17060g)

Final Motor Choice: Cesaroni Blue Streak

- Cesaroni L1395 - BS

Recovery System: Dual Deployment Recovery

- Undergoes separation and deploys a drogue parachute at apogee.
- Undergoes second separation and deploys a main parachute at 700ft.

Rail System: size 1515 rail system

Payload Summary

Payload (Rover) Name: **Rover RICK**

Payload Description

- Upon vehicle landing, a rover containing solar panels will be deployed from the separated nose cone. In order to ensure that our payload will exit the rocket in a correct orientation, the rover will be housed in a bearing housing that will allow the rover to exit in an upright position. The rover will use an ultrasonic guidance system to avoid obstacles.
- Nose separation charges will separate the nose cone from the rest of the rocket body
- The pins holding the bearing housing fixed will release and the housing will rotate to orient the rover in an upright position
- The rover will then deploy from the vehicle and travel a distance of at least 5 feet
- Data about the surrounding atmosphere will be collected using onboard electronics

2. Changes Since PDR

2.1 Vehicle and Recovery Changes

Shock Cord Length

We have changed our main parachute shock cord length from 30 feet to 40 feet after it was brought to our attention during the PDR presentation that we would need a greater factor of safety for main chute deployment.

Ejection Charge Wiring

- The main and backup ejection charges are now wired independently to ensure proper ignition.

Bulkhead Hardware Change

- The hardware that will be used to connect the drogue shock cord after the initial separation was originally going to be two U-bolts but we will be changing that to 3/8 inch eye bolts.

Back up Black Powder Amount

- We have now increased the backup ejection charges to an additional 25% mass of 4F black powder. This will ensure separation in case of main charge failure.

Electro Magnetic Shielding

- We have added electromagnetic shielding to the bulkhead located in the nose cone. This will ensure that the electronics in the nose cone will not be interfered with by the separation charge.

Electronics Activation Switches

- We chose to use a screw mechanism switch in order to engage the altimeter after having issues with the push button switch during the small-scale launch.

Mounting Procedure for Bearings in Rover Housing

- Rather than having the payload housing epoxied directly to the main tube of the rocket, we will be mounting the housing to a section of coupler tube allowing for easier access and construction.

Motor Changed from L1410-SK to L1395-BS

- The motor was changed as a correction to an action item due to the previously selected motor being a skidmark type motor which projects metal sparks.

Total Launch Vehicle Weight Change from 46.12 lbs to 42.95 lbs

- Due to updated component weights the new overall vehicle weight will range from 45 to 50 pounds.

Fin Geometry Change

- The geometry of the fins has been tweaked to maintain an ideal flight profile upon updated weight and motor change. Fin adjustment is projected to be made up until construction of the large rocket due to updating weights.

2.2 Payload Changes

Rover does not stow or otherwise change volume

- The payload team found that the improvements made by utilizing the stowing methods were minimal and added more cost and complexity, and thus the team felt that those resources were better spent elsewhere.

Delrin bearing balls chosen over 3D printed ball bearings

- Upon farther research, it was discovered that the 3D printed ball bearings were too rough and created too much friction, consequently preventing the bearing from rotating consistently and thus the decision was made to buy Delrin ball bearings.

Rover will drive out of housing instead of ejection by a spring

- The spring ejection was found to be unnecessary, as the wheel motors would be counterproductive by resisting the movement the spring would create, and any obstacle that would prevent the rover from driving forward would also prevent spring deployment.

Rover no longer constrained by pin

- The payload team concluded that the rover had enough degrees of freedom constrained without adding the constraint pin in order to ensure that the rover is secure within the launch vehicle.

Rover uses Arduino Micro instead of Raspberry Pi.

- The Arduino is now being used due to its more compact size and familiarity.

Wheel power is adjusted with ESC rather than Raspberry Pi.

- The wheel motors will now be controlled by an ESC rather than the Raspberry Pi.

Added counterweights

- Two different counterweights were added to gain stability to the rocket and to ensure that the bearings rotate when desired.

3. Vehicle Criteria

3.1 Design and Verification of Launch Vehicle

The group has researched different design options for sub-systems of the launch vehicle that include, but is not limited to: the nose cone, airframe, fins, motor assembly etc. Each one of these sub-systems was analyzed with regards to safety, efficiency, complexity, and expense. The design selected for the fabrication stage of the Raider 2 is the “Straight 6” design that was discussed in the PDR, and be represented in the subscale rocket, Raider 1. Raider 1 will directly reflect the groups' research to ultimately provide proof of concept that this platform can safely house a scientific payload while following a specific flight profile. Raider 2 was originally designed in Open Rocket for simulation purposes, and easy manipulation of the flight profile. The final mass of Raider 2 is expected to be near 42.8 pounds, final length to be 9.55 feet, and stability margin to be 2.52 cal. Raider 2 was then designed on Autodesk inventor (figure 3-1) to verify proper fitment and to help provide proper reference material during fabrication.



Fig 3-1

Our team has decided to utilize a 3D printed long elliptical nose cone, with a shoulder for coupler mounting, a straight 6" airframe that will be made out of blue tube, G10 fins to assure stability and reusability, and a Cesaroni L1395-BS 4 grain motor that will use a casing to allow for reloads. More information over each subsystem can be found in their respective sections below.

3.1.1 Airframe

The airframe of the launch vehicle has gone under a critical review of both the components/material selection, as well as the design/geometry. The material of choice is Blue Tube 2.0 with G10 reinforcement ribs where needed, and holes drilled for pressure stability and hardware such as threaded inserts and screws to allow for alignment and securing of couplers and the E-Bay.

3.1.1.1 Structural Elements

Blue tube is an extremely strong material, as it is made out of a vulcanized cellulose fiber, and is used in howitzer shells. Extra reinforcement is required on the airframe at the section where the DACS is stationed due to the large windows that will be cut out for the control arms. The method of reinforcement is by attaching G10 ribs to the inside of the airframe 45 degrees from the windows. These ribs will be fixed to the inside wall of the blue tube airframe with ¼ inch G5000 epoxy. More information over DACS airframe reinforcement can be found in the DACS section discussing individual parts and their roles.

3.1.1.2 Material Justification

Blue Tube 2.0 is vulcanized cellulose fiber. It is tolerant to high temperatures, and not prone to shattering or cracking when encountered with high forces at impact. Below in figures 3-2 and 3-3 is published data from the manufacturer that shows the structural properties of Blue Tube 2.0.

3/12/2009

Sample ID: BlueTube.mss
 Method: Tube Compression (Simple Servo).msm

Test Date: 3/11/2009
 Operator: MTS

Sample Results:
Specimen Results:

Specimen #	Specimen Comment	Inner Diameter in	Outer Diameter in	Platen Separation in	Area in ²	Modulus ksi	Load At Yield lbf
1		3.002	3.128	9.00000	0.60662	559.60219	2974.13082
2		3.002	3.128	9.00000	0.60662	607.10291	3211.11207
3		3.002	3.128	9.00000	0.60662	574.09091	3052.63859
Mean		3.002	3.128	9.00000	0.60662	580.26534	3079.29383
Std. Dev.		0.000	0.000	0.00000	0.00000	24.34486	120.71828

Specimen #	Stress At Yield MPa	Peak Load lbf	Peak Stress psi	Energy To Peak ft*lbf	Break Load lbf	Elongation at Peak in	
1	33.80322	2974.13082	4902.72798	14.11096	1504.89966	0.11156	
2	36.49669	3211.11207	5293.38147	20.93077	1607.34466	0.13095	
3	34.69552	3052.63859	5032.14469	18.27847	1534.46427	0.11815	
Mean	34.99848	3079.29383	5076.08472	17.77340	1548.90286	0.12022	
Std. Dev.	1.37205	120.71828	198.99895	3.43785	52.72665	0.00986	

Fig 3-2

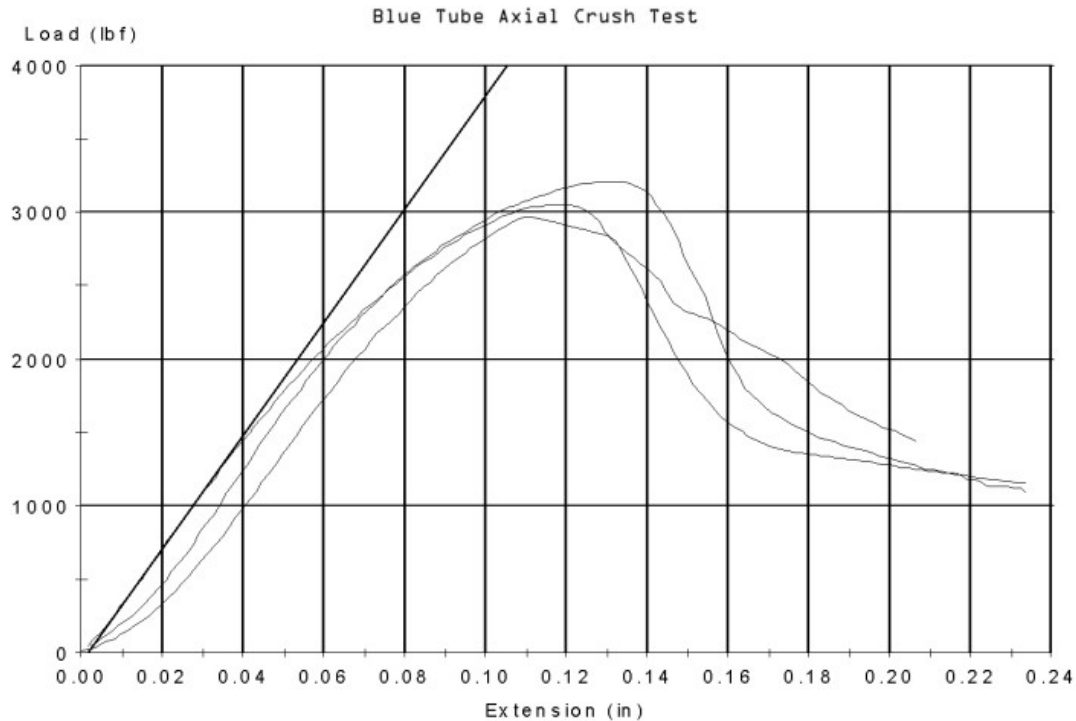

Fig 3-3

3.1.1.3 Completeness

Upon finalizing the design, it has been decided that hardware will be added to the airframe at sections that involve any various mounted features. Some of the features that will require modification of the airframe is the E-Bay and payload housing which will require alignment and retention screws/nuts, couplers that connect sections together will require similar retention hardware, or shear pins if there is separation occurring there. Other features are added such as cut windows for the drag flaps on the DACS and slots that are cut out for the fin-through-body design which are shown in figure 3-4.

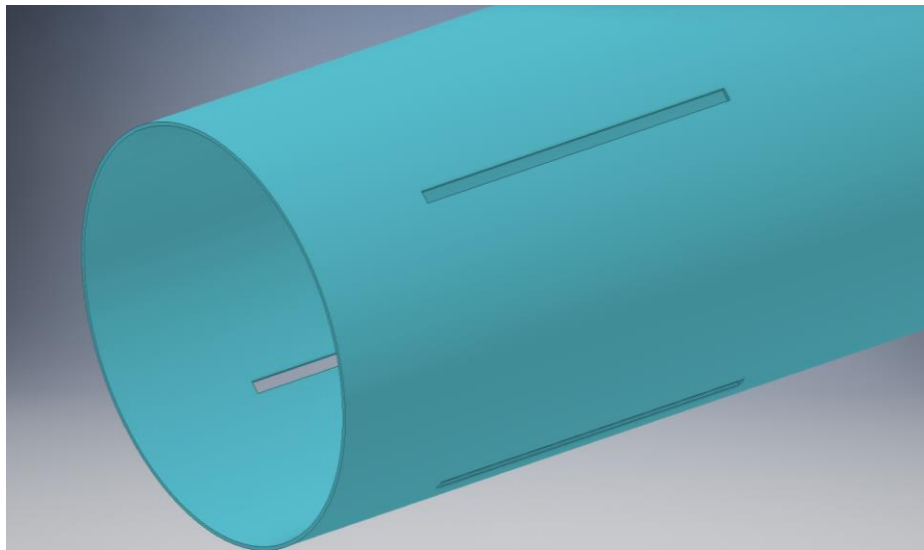

Fig 3-4

One of the most important events of a launch is motor ignition and liftoff, and to assure that this step event goes safely, commercially available Delrin 1515 rail buttons will be attached to the airframe in parallel.

3.1.1.4 Fabrication

For fabricating the airframe, some special tooling will be required tooling will be required such as, a custom 3D printed fin jig that will be used to mark the area to cut. The end-mill will then be used to cut the slots out, and the same process will be used to cut the DACS windows. A standard drill will be used to drill holes in the airframe for alignment, retention, and rail button hardware. Finally, an industrial band saw with the proper blade for cutting composites will be used for cutting the tube to length.

3.1.2 Fins

The fins of the back of the rocket were put under much scrutiny and design review, because of the heavy role they play in the stabilization of the rocket. We chose to design the fins in an Autodesk CAD program (figure 3-5) fabricating them by converting a DXF file that was exported from CAD to a CAM software and sending a tool path to a CNC router that will be cutting into a 1x3 ft. and 3/16 in thick sheet of fiberglass. The geometry of the design was optimized through our simulator program Open Rocket. 3/16 inch Fiberglass was chosen as the material because it is tough, light, and easy to shape and design with. It will be able to withstand the stress of flight, the forces of launch, and strong enough so that the connector piece does not shear off at any point in the flight. The fins must be able to channel the flow of air, reducing the air drag and helping to stabilize the air to reduce the amount of drag while channeling the airflow past the rocket to keep the rocket stable during flight making sure that it doesn't yaw or pitch during flight.

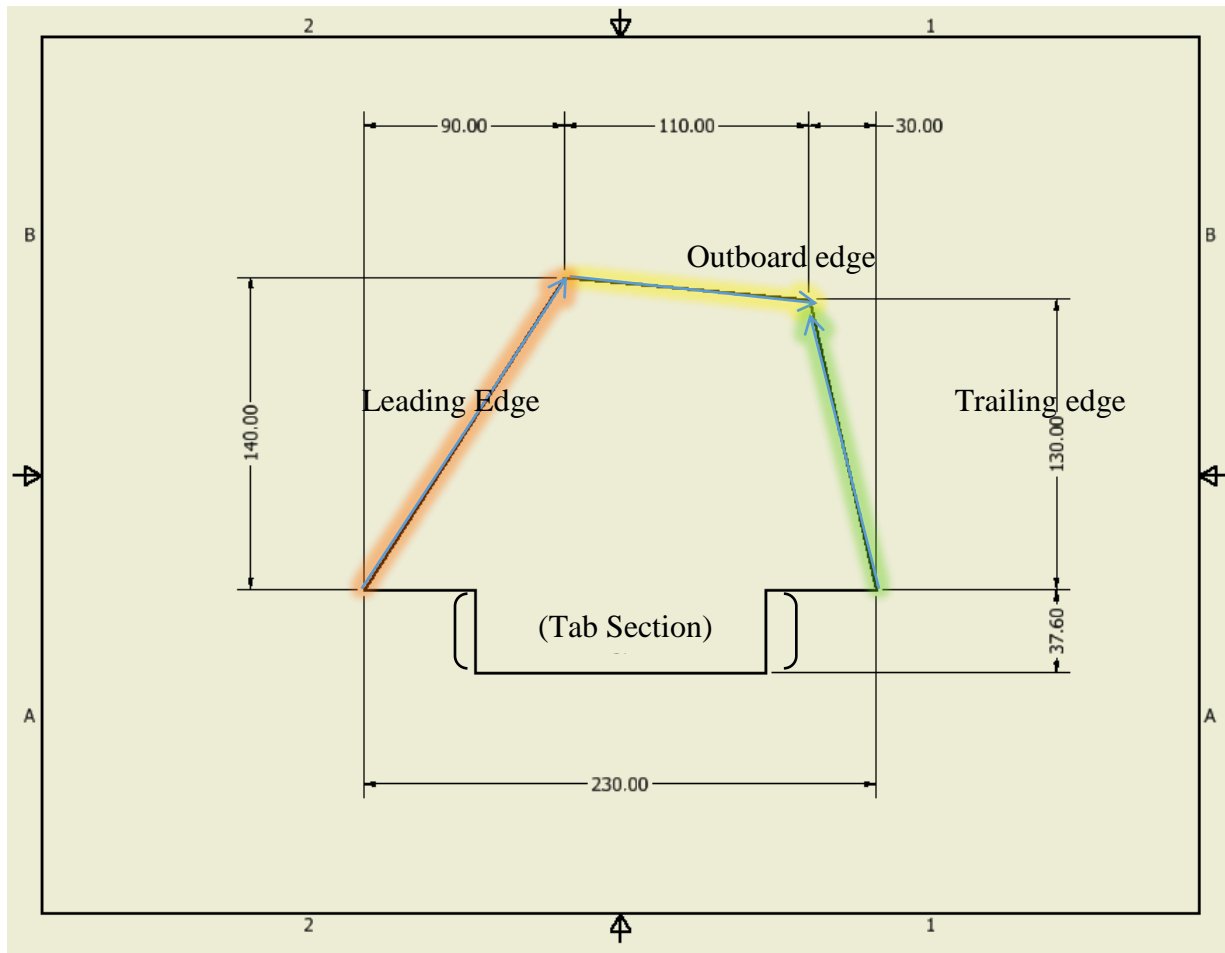

Fig 3-5

We attached the fins to the Airframe body by sliding the fin's connector section into the airframe and then bonding it to the airframe and the inner tube with Rockexpoxy G5000. It was very important to get a strong fillet of epoxy on the fin on the outside of the airframe. Once it is epoxied and everything else is set into place, we will use encapsulating foam as another layer of structure and support to make sure the fins are stable. One important thing about the fins is making sure that they are firmly attached and do not have any risk of coming off during any stage of flight. This is a serious problem, not only because of safety but because this would cause the rocket to start pitching, and yawing and ruin our flight path. Another thing is the manufacturing of the fins, because they are made of fiberglass. However, we will make the DACS flaps of the same type of fiberglass, so we will have experienced with the safety concerns with the shaping and processing of this certain type of fiberglass.

3.1.2.1 Completeness

The fin design was tested on the Raider 1 sub-scale rocket and proved to be a success. Due to the verification, the design has been finalized and is estimated to have a weight of 992 grams, or 2.2 lbs for all four fins.

3.1.3 Nose Cone

The nose cone of the launch vehicle has gone under a critical review of components, design, and geometry. We will be 3D printing the nose cone out of ABS plastic in two parts for the full-scale in a long elliptical shape with a modular rail that allows for a part sled to be seated in the cavity, see figure 3-6 for the CAD design. The shape was chosen because it reduced the amount of frontal area. For the Raider 1, since the nose cone is 1/3 the dimensions of the full scale, it was printed as one piece.

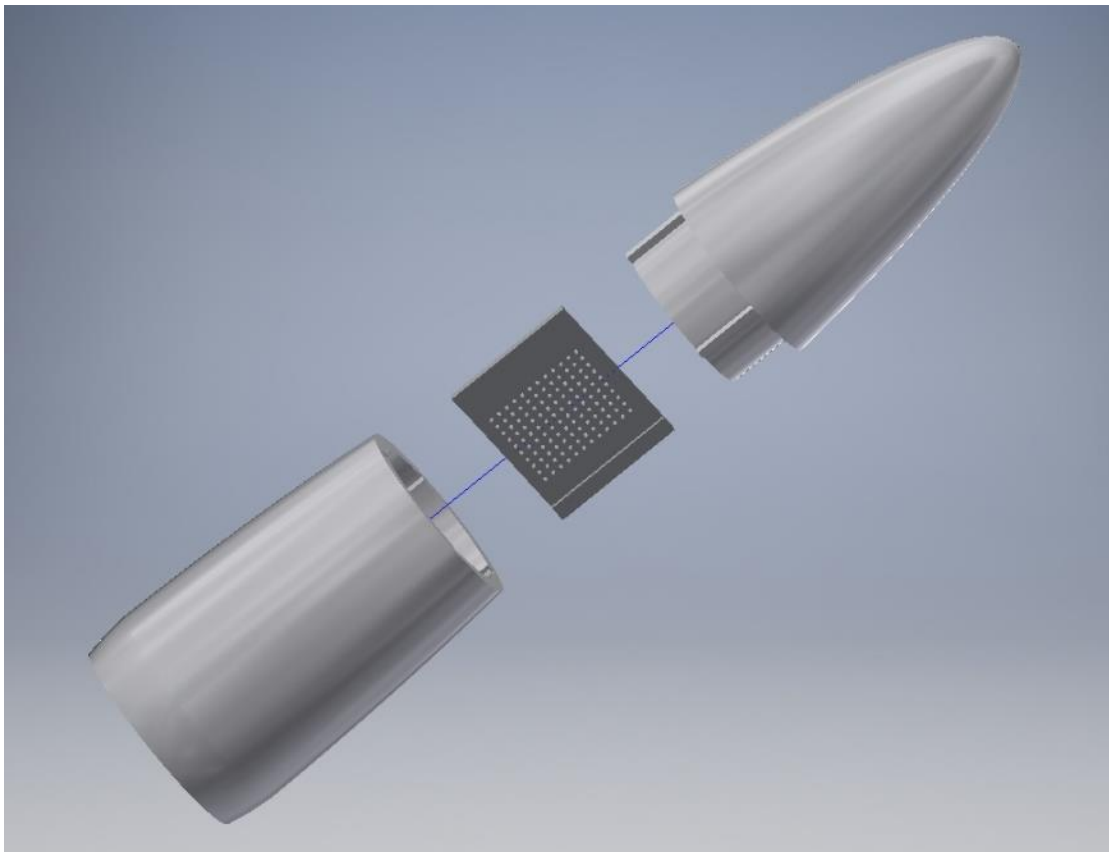

Fig 3-6

3.1.3.1 Aerodynamic Elements

The Aerodynamics of the nose cone has a great influence on the flight of the Raider rockets, and has been a major point of concern for research and optimization. The main reason that it was chosen is because it has the lowest amount of frontal area and thus has a lower coefficient of drag as opposed to other nose cones. Raider 1 and 2 rockets will not achieve a flight speed above Mach 1, so the aerodynamic drag characteristics will be tailored to sub-subsonic conditions. The Research has shown that the most aerodynamic shape for this situation is a long elliptical geometry. A graph showing the relationship between surface drag and nosecone shape is shown in figure 3-7 below.

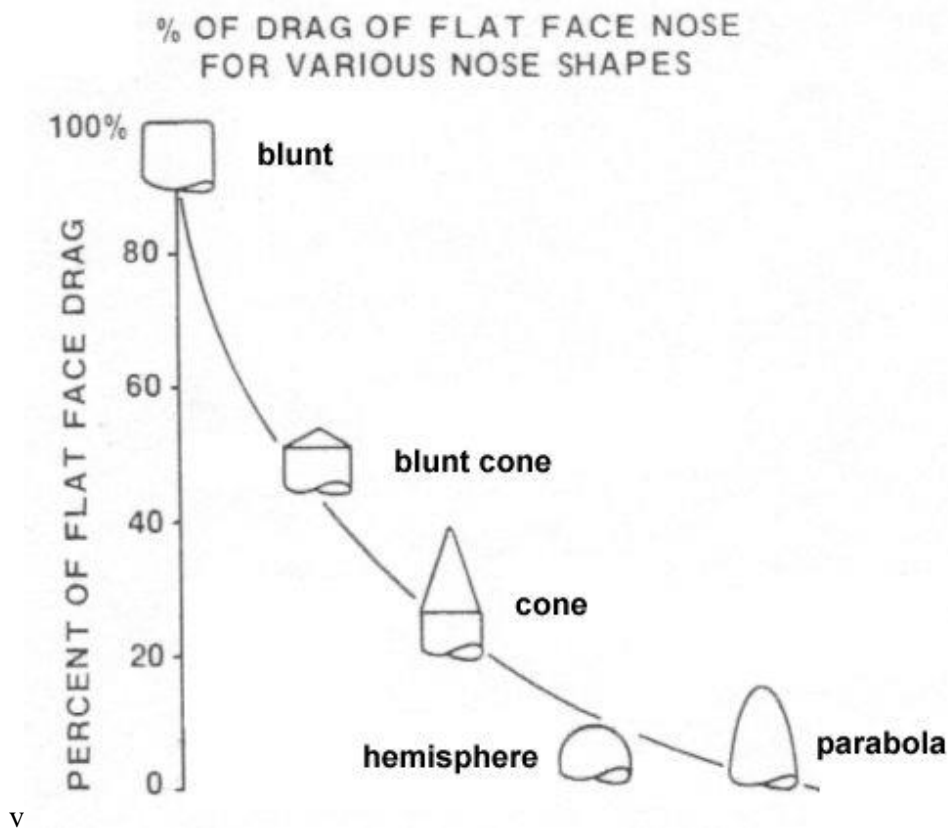

Fig 3-7

3.1.3.2 Material Justification

The team chose to 3D print the nose cone in ABS plastic because of flexible design, low cost, and ideal shape. Fabricating the nose cone will be done the same way for Raider 2 as it was done for Raider 1, being DFM 3D printing techniques and utilizing a Stratasys 3D printer that is

equipped with dual filament printing for both ABS model material and dissolvable support material. ABS plastic or Acrylonitrile Butadiene Styrene is a thermoplastic material that is commonly used in 3D printers that is melted, set, and cooled. ABS plastic has a high density of 60%. 6in diameter nose cones on the market sell for \$130+ with little to no information and most come in an ogive shape while 3D printing is a significantly lower cost considering the 3D printer in the ME shop is free to use for projects. From an experiment posted on Apogee Rockets Newsletter, it found that the nose cone with the lowest drag coefficient was a long elliptical versus ogive which was ranked on the lower half of the results. In addition to 3D printing our nose cone, we can design the dimensions at the same time as working to make sure the simulation on Open Rocket will reach our predicted apogee. This design was verified during the sub-scale launch.

3.1.3.3 Completeness

With finalizing the design, it has been decided that the nose cone will have a vertical guide rail interface that will allow for the part sled to be seated in the bottom, and allow for the tip to attach to the bottom and seal the cavity. The part sled has already been printed and is shown in figure 3-8 below. The dimensions have also been finalized for both sub-scale and full scale with the height of the sub scale is 6.67 in with a 2 in shoulder and the full scale will be 20 in with a 5.5 in shoulder that will be made from a blue tube coupler inserted into the nose cone. The estimated weight of the nose cone is 1400 grams from the open rocket simulation, and this mass number will be updated when the print has finished.

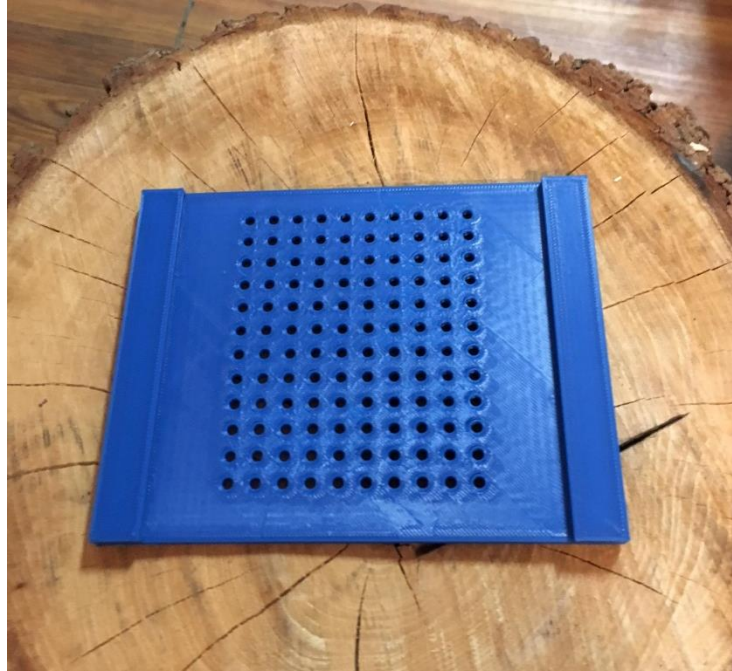

Fig 3-8

3.1.4 Motor Mount Assembly

The motor mount assembly will be constructed around the Cesaroni L1395 Blue Streak motor, and include key components such as centering rings, a thrust plate, screws that tie into the thrust plate, fiberglass motor mount, and a retainer ring. The selected motor produces a relatively large amount of force with a total impulse of 4895 Ns and a maximum thrust of 1,800N. Due to the amount of stress this will cause on the motor mount, a thrust plate will be used, accompanied by a series of wooden centering rings and encapsulating foam. The motor mount will be attached to the rocket by strong bonds of both epoxy resin and foaming epoxy between the fin inserts, the motor inner tube, centering rings, and the airframe. Finally, the motor assembly will utilize a thrust plate and a retainer ring to seal the motor assembly and hold the fuel grain, nozzle, and casing together. A graphic of the thrust plate mounting technique is shown in figure 3-9.

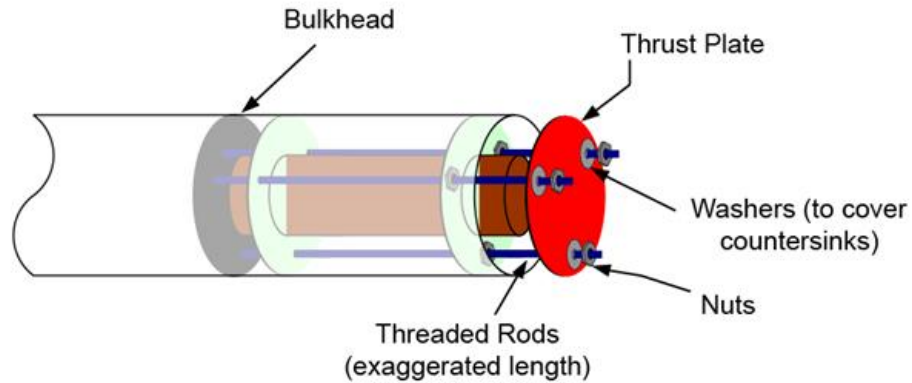

Fig. 3-9

3.1.4.1 Structural Elements

The structural integrity of some key components such as the thrust plate have been analyzed using FEA simulation software at the event where the highest amount of force will be seen, which for the motor mount will be the period of maximum thrust. (seen in figure 3-10) This component has been determined safe to use due to the maximum Von Mises stress being 33.49 MPa and the yield stress of 6061-T6 Aluminum being 240MPa. This will create a factor of safety of 7.16. Other factors that will affect the structural integrity of the motor mount is the shear strength of the epoxy and the volume and density of the encapsulating foam being used.

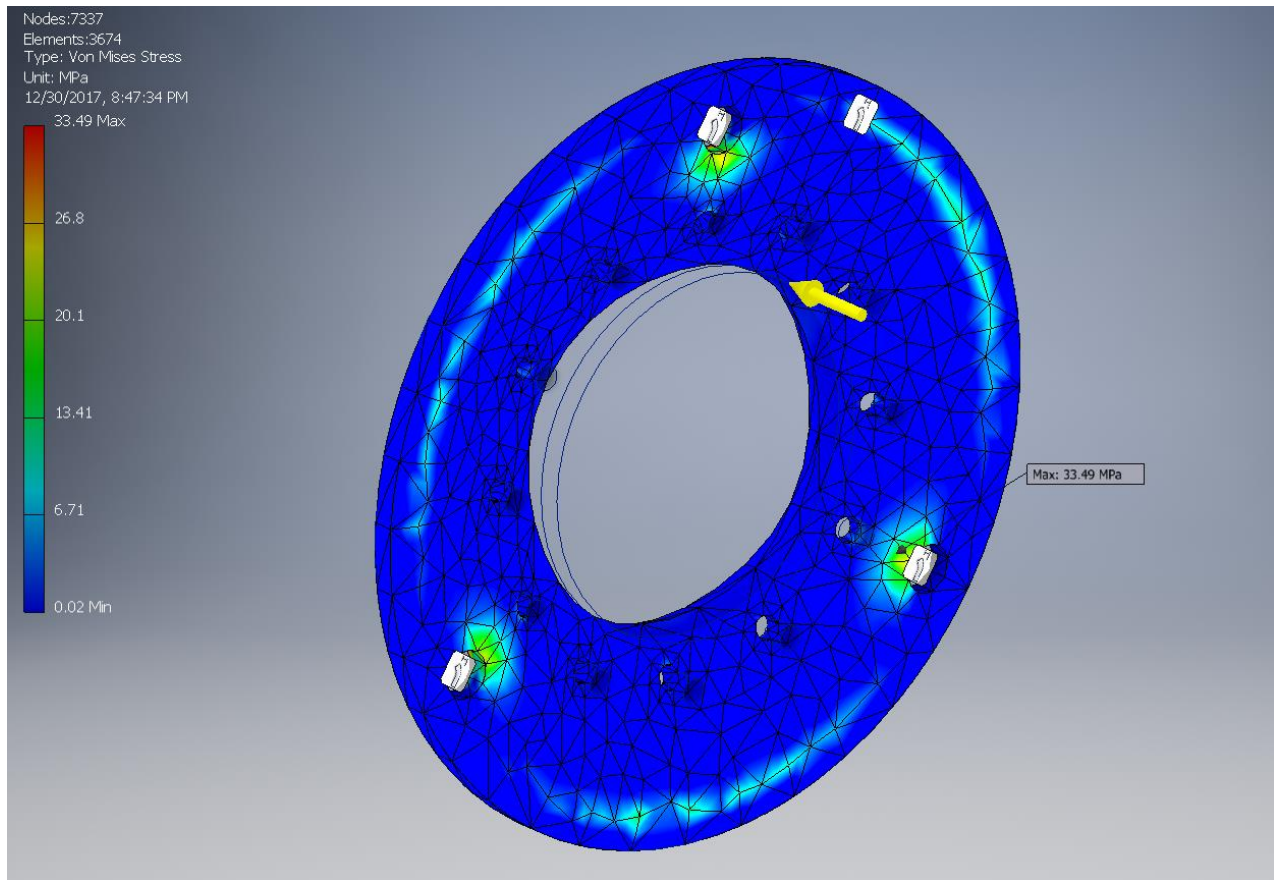

Fig. 3-10

3.1.4.2 Material Justification

The materials that are chosen to be a part of the motor mount assembly reflect their individual roles by tailoring to the requirements that each component must hold up to. Because there are various roles that each component will play, there is various materials that are selected, for example, the centering rings will be made from laminated plywood. The centering rings do not need to be very strong because the thrust plate will divert most of the intense force from the motor away from the centering rings. Other components such as the inner tube will be made from a fiberglass composite. We chose this material due to its availability as a surplus piece that was provided for free, and verified it's use because of its excellent strength and proven ability to function as a 75mm motor mount. The Thrust plate will be made from 6061-T6 Aluminum with holes for mounting hardware of threaded steel rod with nuts and lock washers. This is the material that the commercially available thrust plates uses and has a melting point of 1,085 degrees Fahrenheit. The retaining ring will be similar to the retaining ring used on the sub-scale model,

made out of steel with one side fixed to the motor mount and the other threaded, however scaled up to fit the 75mm motor. The Adhesives being used are the same Rocketpoxy G5000 that will be used on the fins, bulkheads, and various bonding needs, as well as an additional epoxy foam to encapsulate the fins and fill and bond to all components inside the aft end of the rocket and around the inner tube. Both are two-part thermoset polymers, with one part being a resin and the other a catalyst that acts as a hardener/reactant that causes the foaming process. See data sheets in the appendix for epoxy information.

3.1.4.3 Completeness

The components of the motor retention system are all compatible with the 75mm motor. The thrust plate and retainer ring have concentric holes that allow for nuts and bolts for mounting. The fin-through body design that was discussed in a previous section also compliments the motor retention system by using the tab length as a secondary form of mounting, and the encapsulating foam as a tertiary form. The chambers that will be filled with foam will be in between the centering rings, shown in figure 3-11.

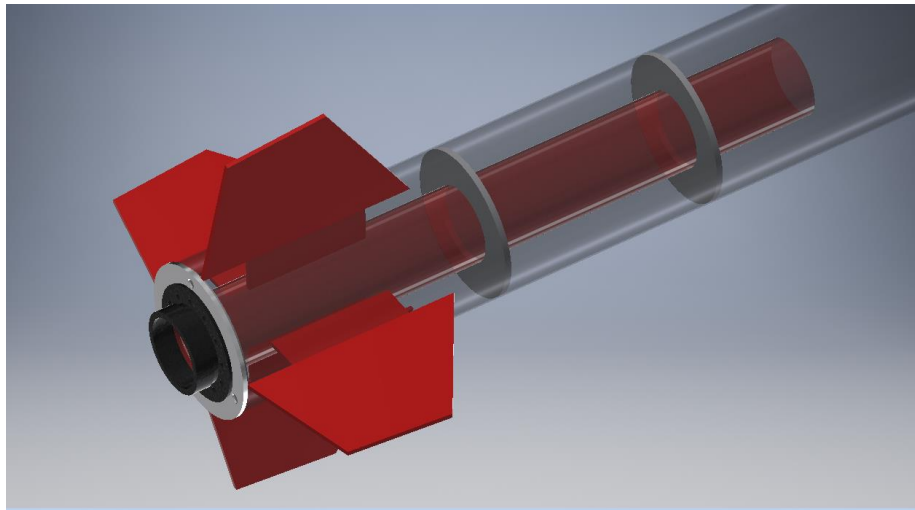

Fig 3-11

3.1.4.4 Fabrication

While some ideas were considered to design and fabricate some components of the motor retention system, it has been decided that the specialized components such as the thrust plate and retainer ring will be purchased from a licensed manufacturer to ensure no failure occurs and decrease the time required for full-scale part sourcing and assembly. Other aspects of the retention system like centering rings, inner tube, foam and, epoxy will be fabricated, or measured and applied in house using a CNC router for custom shape cutting, band saw for cutting the tube to length, and precise scales for measuring weight of consumables.

3.1.5 Propulsion System

The motor that was selected to be used in the full-scale launch vehicle is the Cesarani L1395-BS. This motor is a multi-part sub assembly that consists of an aluminum casing with front and rear closures, a four-grain Ammonium Perchlorate fuel grain that uses a flexible binder to hold the fuel and oxidizer together and prevent the grain from cracking thus creating an uneven burn. The solid propellant motor has ideal properties for the size and weight of the launch vehicle and will be the best replacement for the previously selected motor that had a “skid mark effect” by projecting smoke and sparks and cannot be used in the USLI competition.

This motor’s chemical makeup, Ammonium Perchlorate, is one of the most widely used solid propellants. This crystalline oxidizer is so common for many reasons, but one aspect is the way in which this compound can easily be mixed with catalysts or other fuel enhancers. For the Cesarani L1395-BS, the exact chemical mixture is not listed. There are percentage ranges of the amount of Ammonium Perchlorate, metal powders, and synthetic rubber on the Safety Data Sheet. Though the actual amount remains unknown, the main reaction of the Ammonium Perchlorate and its stoichiometry is listed below:

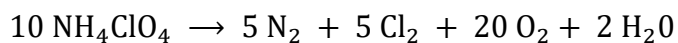

The other additives that are mixed in with the Ammonium Perchlorate give the engine many desirable traits which play into the overall objectives. For example, the synthetic rubber additive in the Cesarani L1395-BS provides the mixture to flex inside of the canister holding the fuel. Without this rubber, the solid mixture would run a chance of cracking during transportation or

could be susceptible to humidity/weather changes. Another one of the additives is the metal powders used as a catalyst for the engine. Though the exact catalyst in the Cesaroni L1395-BS is not listed, the quick burning, blue flame is a result of the metal powder in the engine. This will result in an engine with high amount of thrust in a short amount of time which is perfect for our vehicle needs.



Fig 3-12

The casing that the engine will be held in is a Cesaroni 75mm 4-Grain Hardware Set and is shown in figure 3-12. This casing is made T6 aluminum and can hold an internal pressure of over 3000 psi. The set will include not only the casing, but also the closure, and retaining rings. This set is the one recommended by Cesaroni for our L1395-BS engine.

For our full-scale model, this 4-grain engine will be the best commercial available engine to meet the mission objectives. An average thrust of 1779.9 N, a total impulse of 4895.4Ns and a burn time of 3.5 seconds will give our rocket the needed force to lift itself and the payload up the targeted apogee. Along with this the casing is the perfect fit for this ideal engine. Below, the thrust

curve can be found in figure 3-13, and the safety data sheet can be found in the appendix section of this document.

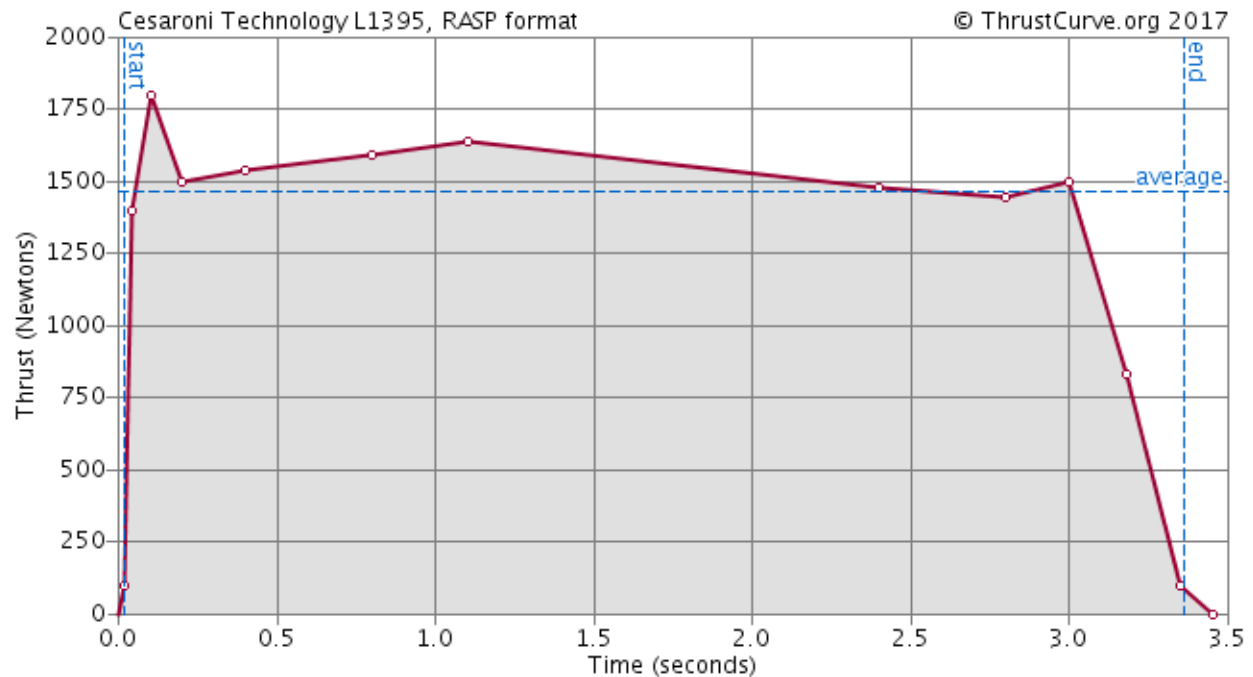

Fig 3-13

3.1.6 Bulkheads

The Raider 2 will have a total of six bulkheads throughout the vehicle where they are broken up into pairs. The three pairs will exist to connect the nosecone to the bulkhead directly in front of the rover housing which protects the rover from ejecting the nosecone after landing and the bulkhead receded into the nose cone. The drogue bulkheads which are situated directly behind the rover housing and the forward most bulkhead on the electronics bay. Last, the main bulkhead's with on being situated at the aft most portion of the electronics bay and directly above the DACS system. A more detailed and in-depth explanation of each specific bulkhead is given in recovery section [3.5.1.3](#).

3.2 Flight Predictions

Open Rocket has been the simulation software of choice for this project, due to its ease of use and availability as an open source software. However, because it is open source, we had to verify that it could be relied upon as an accurate source. The verification method was modeling Raider 1 in Open Rocket and compare the actual altitude with the projected. More information about the Raider 1 flight analysis can be found in its respective section.

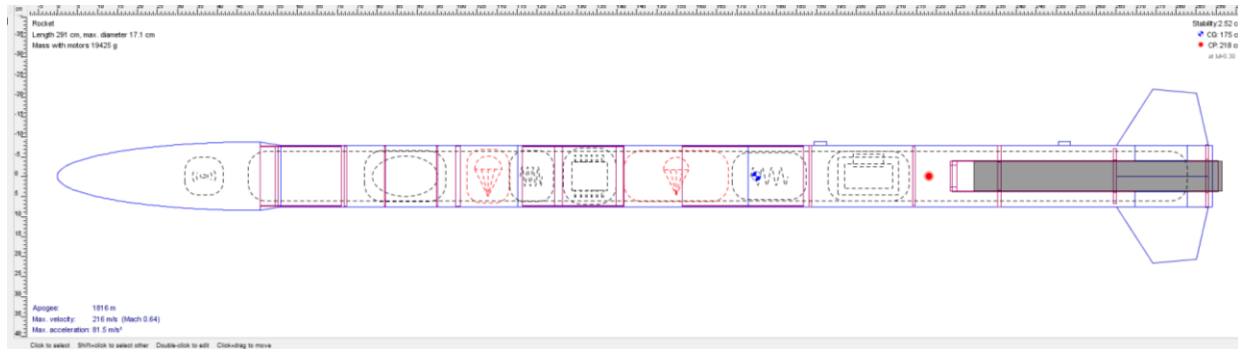

Fig 3-14

The drag characteristics were modeled from Open Rocket, and more research has gone into verifying the math that was used in the simulation software. Figure 3-15 is a chart that shows the coefficients of drag for each component of Raider 2. Equations were pulled from the technical document that breaks down the software for identifying the total coefficient of drag, by including a reference area for Cd summation.

$$C_{D0} = \frac{A_{\text{component}}}{A_{\text{ref}}} \cdot C_{D\bullet}$$

Component	Pressure C_D	Base C_D	Friction C_D	Total C_D
Nose cone	0.02 (5%)	0.00 (0%)	0.04 (9%)	0.06 (14%)
Transition	0.00 (0%)	0.00 (0%)	0.00 (1%)	0.00 (1%)
Body tube	0.00 (0%)	0.00 (0%)	0.05 (12%)	0.05 (12%)
Body tube	0.00 (0%)	0.00 (0%)	0.05 (11%)	0.05 (11%)
Body tube	0.00 (0%)	0.11 (27%)	0.09 (23%)	0.20 (50%)
Freeform fin set	0.01 (3%)	0.00 (0%)	0.03 (8%)	0.04 (11%)
Launch lug	0.00 (1%)	0.00 (0%)	0.00 (0%)	0.00 (1%)
Launch lug	0.00 (1%)	0.00 (0%)	0.00 (0%)	0.00 (1%)
Total	0.04 (9%)	0.11 (27%)	0.25 (64%)	0.40 (100%)

Fig 3-15

3.2.1 Flight Profile

The desired flight profile of the Raider 2 follows a flight profile that is very typical for high powered rockets, with an added stage for apogee correction. This is laid out in the bullets below:

- Safe motor ignition
- Motor burnout
- Dynamic apogee control
- Apogee and drogue deployment (5280 feet AGL)
- Main deployment (700 feet AGL)
- Touchdown
- Nose cone separation
- Rover deployment

3.2.2 Simulation Data

The Open Rocket simulation data was plotted on the graph in figure 3-17 below and directly reflects the flight profile by modeling the velocity, altitude, and acceleration. The simulation was run by using environmental data that represents the average weather conditions that will be seen at the launch site in Huntsville, shown in figure 3-16 below. The projected apogee is 5,958 feet before apogee correction. The DACS will bring the actual apogee down to close to 5,280 feet.

Temperature: High (deg F)	74
Temperature: Low (deg F)	50
Humidity	<30%
Wind Speed (mph)	6.5
Latitude	34.73deg
Longitude	-86.586deg
Elevation(ft)	669

Fig 3-16

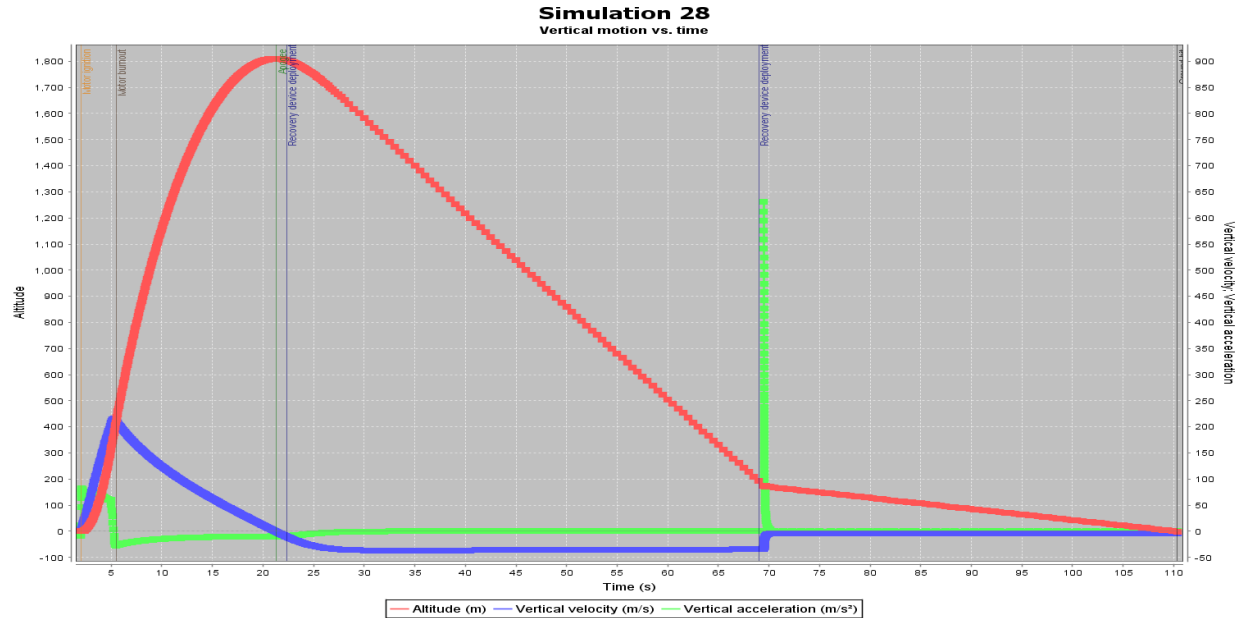

Fig 3-17

The simulation data from Open rocket shows Raider 2 as stable with the stability margin of 2.52 cal. This is determined by applying the Barrowman Equations to find the Center of Pressure (Cp) and running a quick calculation with the Center of Gravity (CG) shown below in the equation and a visual representation in figure 3-18.

$$\frac{(CP - CG)}{d} = \text{Stability Factor}$$

$d = \text{Diameter}$

Stability: 2.52 cal

● CG: 175 cm

● CP: 218 cm

at $M=0.30$

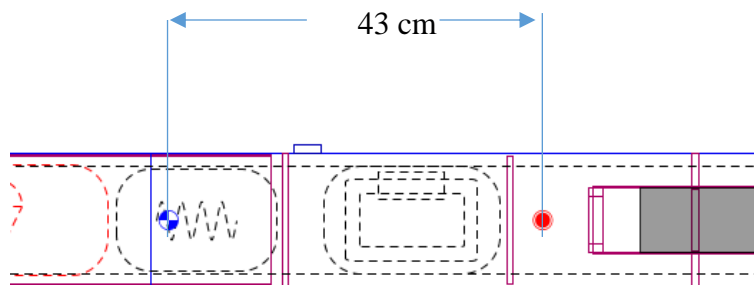

Fig 3-18

The projected Thrust to weight ratio of Raider 2 is 7.66. This was calculated by running the calculation that is shown in the equation below.

$$\frac{\text{Average Thrust}}{\text{Weight}} = \text{Thrust to weight ratio}$$

Other general information over Raider 2 is the length (9.55feet), diameter (6 inches) , maximum velocity (708 feet/sec) and maximum acceleration (226 feet/s²). This data is shown in metric below.

Rocket	
Length 291 cm, max. diameter 17.1 cm	Apogee: 1816 m
Mass with motors 19425 g	Max. velocity: 216 m/s (Mach 0.64)
	Max. acceleration: 81.5 m/s ²

The Rail exit velocity is an important factor to consider with the launch of Raider 2. In order to comply with USLI handbook sanctions, the launch Vehicle must have a rail exit velocity of at least 52 fps. This requirement will be met, as the expected rail exit velocity is 62.32 fps.

3.2.3 MatLab Verification

Now that the final engine has been selected and having a better picture of what final mass would turn out to be, our team ran some of the same verification codes in Matlab to once again establishing that our predictions of this engine were correct.

Due to the fact that this motor is our ideal engine candidate, hand calculations were done to confirm the data we received in OpenRocket. In Matlab, a simple code using the linear momentum equation:

$$m(v1) + \int F dt = m(v2)$$

And the velocity equation:

$$v = \frac{ds}{dt}$$

Together gave us plots of velocity vs time and position vs time our rail exit velocity of:

$$v_{rail\ exit} = 63.272\text{fps} \left(19.285\frac{m}{s}\right)$$

The calculation above shows that the velocity that our rocket will accelerate too by rail exit is higher than the given minimum velocity of 52 fps. The graphs shown below are the time it takes to reach the top of the rail and the velocity reached at rail exit.

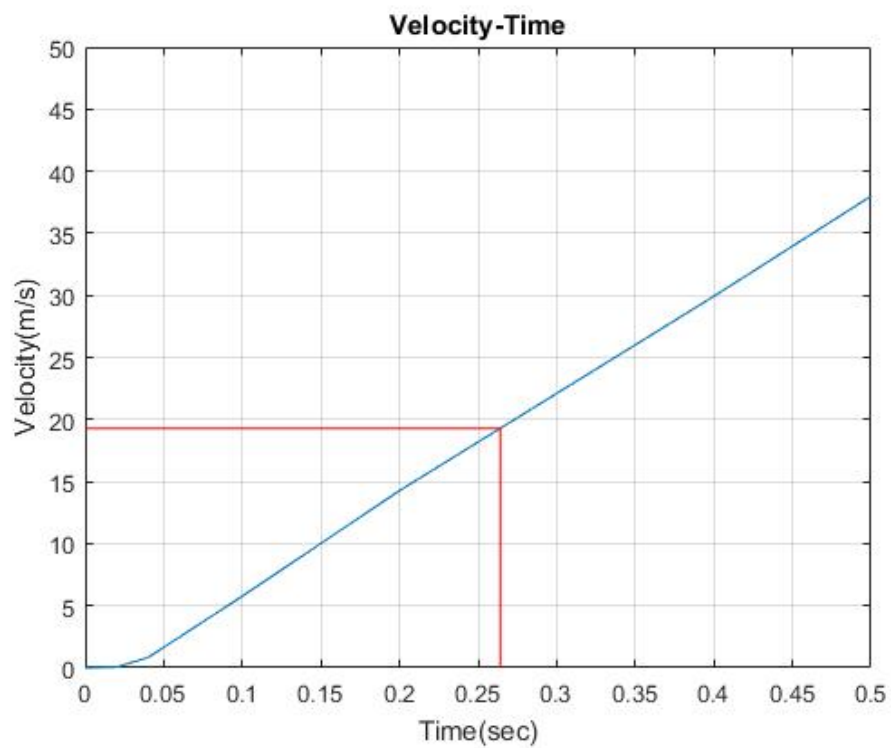

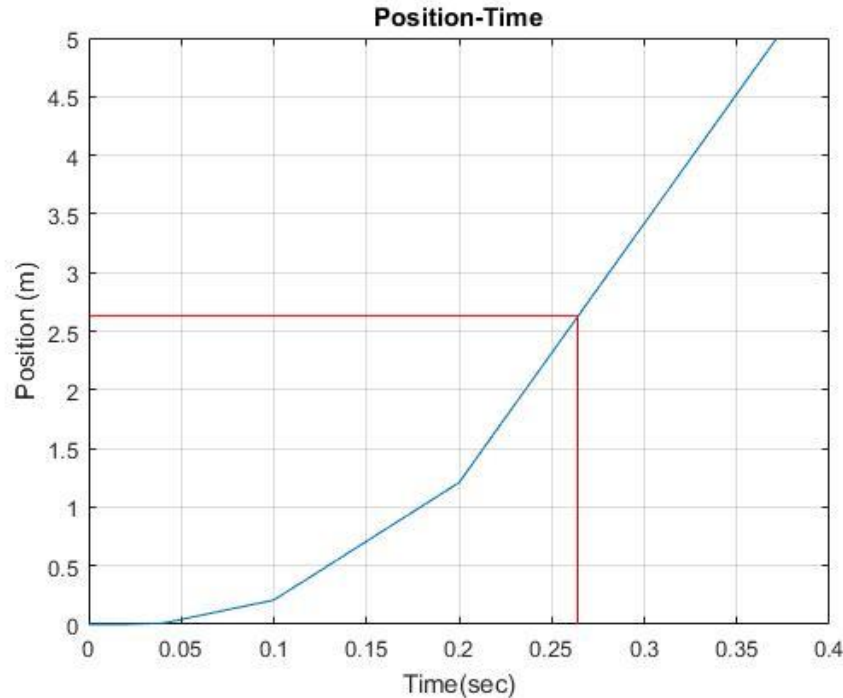

Fig. 3-19

Another calculation done with the help of Matlab was a validation of the apogee we received in the OpenRocket simulation. To help simplify some of these equations, we assumed a constant mass for the duration that the engine will burn. Knowing this mass loss would inevitably affect the apogee calculated, a small, but reasonable amount error was expected with these results. In order to calculate the vehicle's apogee, a burn time was needed to calculate our velocity and height when engine burn out occurred. Our burn time (tb) equation came out to be the total impulse (I) divided by the average thrust (T):

$$tb = IT$$

Before our main velocity and heights could be calculated, a wind resistance factor needed to be accounted for. Using air density (ρ), the coefficient of drag our rocket body (Cd), and the cross-sectional area of our rocket body (A), the equation for wind resistance came out to be:

$$k = 12\rho CdA$$

Including both calculated values with the mass of our rocket (m) and the gravitational constant (g), the values for the height (zb) and the velocity (vb) at engine burnout were calculated:

$$z_b = (-m_2k) \ln(T - mg - kv^2T - mg)$$

After burnout, the value of mass changes to the mass of the rocket without fuel (m_{ab}) and our thrust (T) goes away. This causes the equation for height to be modified to an equation for coasting height (z_c):

$$z_c = (m_{ab}^2k) \ln(m_{ab}g + kv^2m_{ab}g)$$

Finally, adding our burnout height and our coasting height together we get the estimated apogee:

$$Z = z_c + z_b$$

3.3 Sub-Scale (Raider 1)

The sub-scale build was a crucial step in the design process as it proves concepts of design, provides an opportunity to apply construction methods, generates more experience, and sparks more interest within the team. Although the concepts of the sub-scale rocket are the same as the full scale, only key design components, fabrication, simulation, flight results, and a reflection will be discussed in detail in the section below.

3.3.1 Fabrication/Construction

Because the subscale was designed to replicate the full-scale launch vehicle, similar methods of fabrication such as creating custom tooling and finishing processes are being tested and applied. Because this is the first high powered rocket build for some, it has been made a priority to work under the supervision of our mentor Bill Balash, to expedite the learning curve, refine methodologies, and identify any problems that could be corrected, ensuring construction of the large scale runs as smooth as possible. Attached in Appendix B is the fabrication manual that was created during the construction of the subscale rocket to aid the Raider Aerospace Society and constituents in future building of high power rockets.

3.3.2 Flight Predictions

Raider 1 was designed using Open Rocket (figure 3-20) and updated to the actual component weights during construction up until finalization. To ensure accurate simulation data, the launch day conditions were noted and confirmed in Open Rocket and simulated mass for epoxy and hardware was added to correct total weight discrepancies. An extra function of the sub-scale launch was to test the accuracy of the simulation software to verify that it can be used to make reliable predictions.

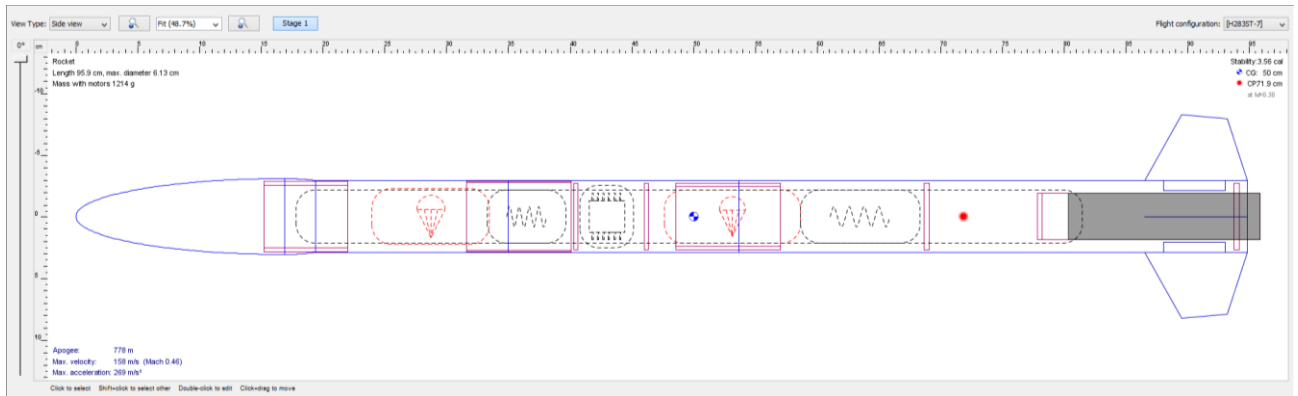

Fig 3-20

With updated masses, the CG was located 19.69, and the CP was 28.3 inches from the nose cone tip. The stability margin was 3.56 cal. The total length was 37.76 inches and the diameter 2.1 inches. The total mass on the launch pad was 2.67 pounds and mass at motor burnout was 2.46 pounds. The projected apogee was 2,549 feet. This data is shown in metric units from open rocket in figure 3-21 and the plot, figure 3-22, below.

Apogee:	778 m	Stability: 3.56 cal	Rocket
Max. velocity:	158 m/s (Mach 0.46)	CG: 50 cm	Length 95.9 cm, max. diameter 6.13 cm
Max. acceleration:	269 m/s ²	CP: 71.9 cm	Mass with motors 1214 g
		at I/F=0.30	

Fig 3-21

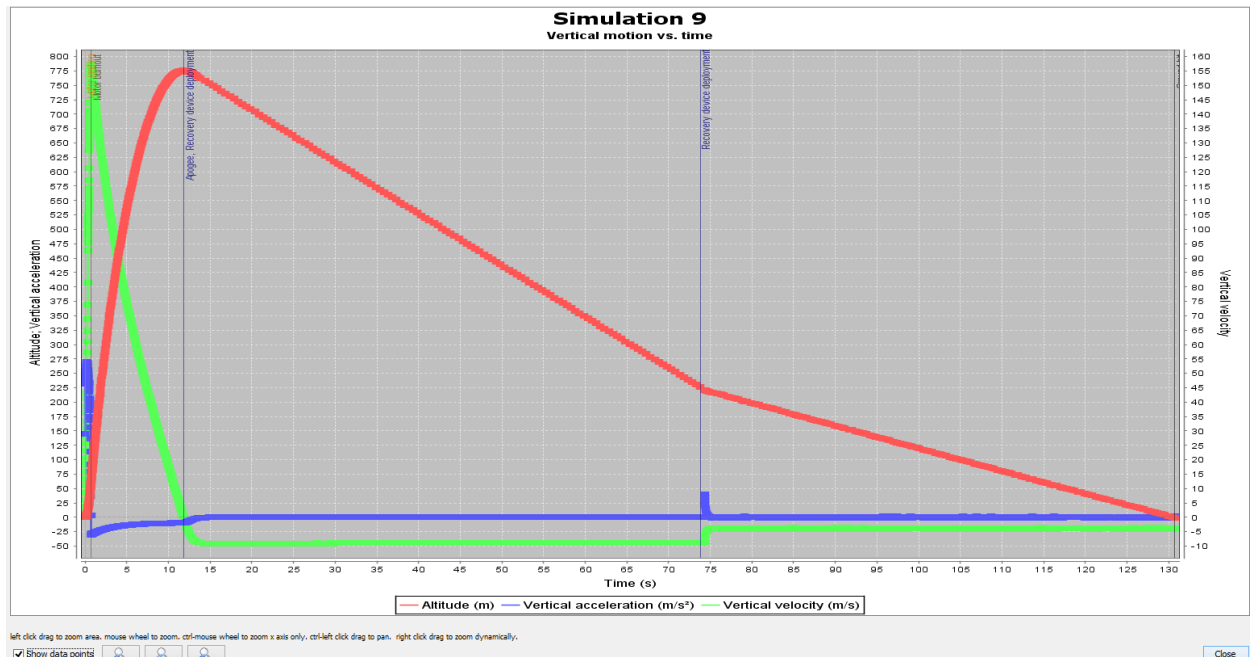

Fig 3-22

The official simulation that is used for analyzing in this report was ran hours before the launch at Cal Farley's Boys Ranch, TX with the weather conditions adjusted to reflect the conditions at the time of launch. These conditions are shown in figure 3-23.

Weather Conditions	
Wind (10mph)	10
Temperature (Fahrenheit)	59
Latitude (degrees)	35
Longitude (degrees)	-102
Altitude (feet)	3,186

Fig 3-23

The simulation returned some surprisingly good results for the coefficient of drag. For this sub scale model our total coefficient of drag came out to be 0.47 which can be seen in figure 3-24. This answer seems to be within reason for our subscale launch and will help in the analysis of the full-scale.

Component	Pressure C_D	Base C_D	Friction C_D	Total C_D
Nose cone	0.02 (5%)	0.00 (0%)	0.04 (9%)	0.06 (14%)
Transition	0.00 (0%)	0.00 (0%)	0.01 (2%)	0.01 (2%)
Body tube	0.00 (0%)	0.00 (0%)	0.04 (10%)	0.04 (10%)
Body tube	0.00 (0%)	0.00 (0%)	0.05 (11%)	0.05 (11%)
Body tube	0.00 (0%)	0.12 (25%)	0.12 (25%)	0.24 (51%)
Freeform fin set	0.02 (4%)	0.00 (0%)	0.04 (9%)	0.06 (13%)
Total	0.04 (9%)	0.12 (25%)	0.31 (66%)	0.47 (100%)

Fig 3-24

3.3.3 Launch Report

The launch of Raider 1 achieved the same flight profile that was expected and was successfully recovered. The achieved height was 2,495 feet, and comparing that to the prediction of 2,549 feet, there is a margin of error of 2%. Shown below in figure 3-25 is the flight data that was recorded using the on board altimeter.

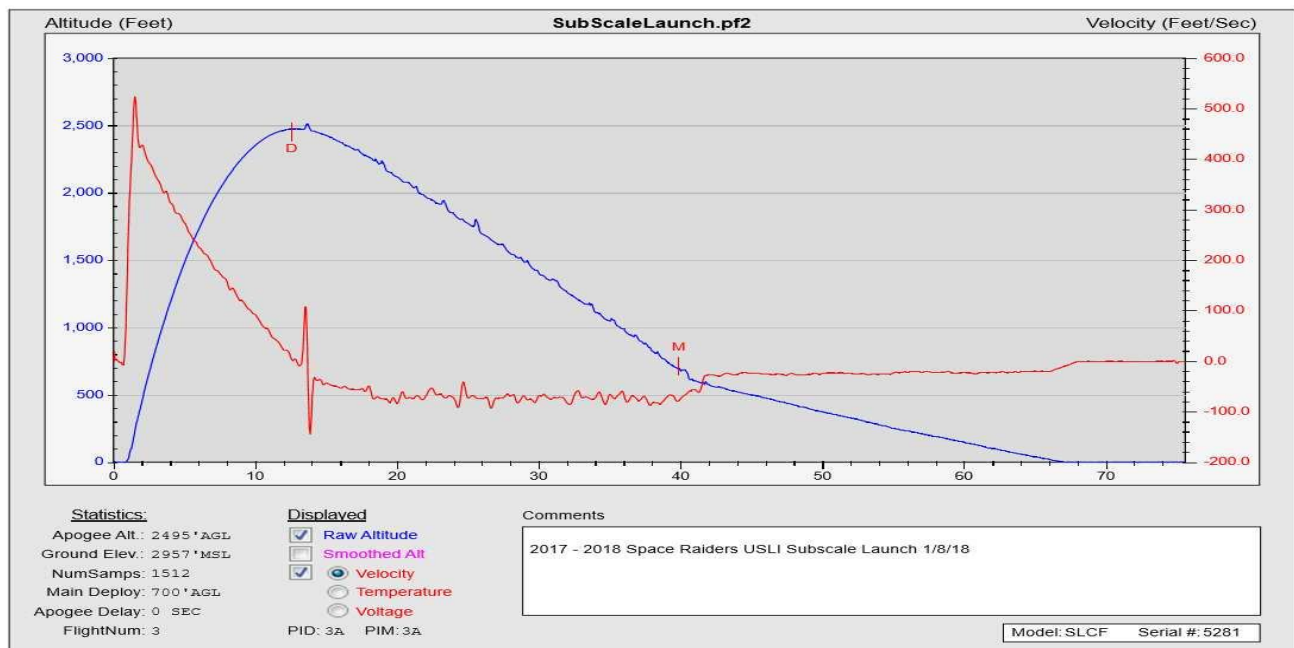

Fig 3-25

3.3.4 Modeling and Scaling Factors:

One of the first things that must be stated is that when comparing our subscale and full-scale rockets, the model is already assumed to be a distorted model. This means that not every variable

accounted for or scaled when launching our subscale rocket. For example, our team could not scale the density of air or gravitational acceleration. Acknowledging that this is a distorted model simply means that we should expect some level of error in our similitude equation's results. Even with this, the information inferred about our full-scale model will be valuable and built upon none the less.

In transforming all the geometries from the full scale to the subscale, each length was transformed by a factor of three. This translated to having a scaling factor of:

$$k = 1/3$$

For the powered flight portion of our rocket launch, the equation generally used for acceleration is:

$$a = \frac{T - D}{m} - g$$

With T being the thrust of the engine, D being the drag force, m being the mass of the rocket, and g being acceleration due to gravity. Both our subscale and full scale use this acceleration equation with the thrust and drag force equations listed below.

$$T = [\rho_e V_e^2] A_c$$

$$D = \frac{1}{2} C_D \rho V^2 A$$

If the density and velocity at the exit of our engines comes out to be similar, it can be inferred that our area is proportional to thrust. This same principle can be applied to the drag force too as it is also proportional to area. Both k factors in the previous two equations come from the fact that area is just a length squared. Since k is a length relation, it would have to be squared for similitude to translate. The equations of similitude for thrust and drag force comes out to be:

$$T_{ss} = k^2 T_{fs}$$

$$D_{ss} = k^2 T_{fs}$$

For the mass relation between the full and sub scales, it was important to realize that mass is dependent on volume and not area. Placing this principle into math, the equation of similitude for the mass come out to be:

$$m_{ss} = k^3 m_{fs}$$

Now we are left with three equations for the variables in our previous acceleration equation. It is now possible to relate the acceleration during the powered portion of our flight between our subscale and our full scale.

$$a_{ss} = \frac{k^2(T_{fs} - D_{fs})}{k^3 m_{fs}} - g$$

Performing a bit of algebra, we are left with the following similitude equation:

$$a_{ss} = \frac{1}{k} \frac{(T_{fs} - D_{fs})}{m_{fs}} - g$$

The next step of our analysis is extremely interesting but is entirely dependent on our subscale and full-scale rockets both having the same fuel chemistry. The first equation listed below is the similitude equation for the mass of the fuel for each engine. This is the same equation which was used for total mass above, but for the next step in the analysis this mass will be referring to total fuel mass. Moving forward with the assumption that the motors do have the same or a negligible difference in chemistry, the mass flow rate for the full scale would come out to be the second equation listed below.

$$m_{ss} = k^3 m_{fs} \text{ (total fuel mass)}$$

$$\dot{m}_{fs} = \rho_e V_e A_{fs}$$

A similitude equation for the subscale can also be derived from the logic used in the thrust similitude equation above. Since the velocity and fuel density of the two engines is assumed to be similar, the equation can again be seen to depend only on area and a k squared similitude equation for the mass flow rate can be derived as seen below.

$$\dot{m}_{ss} = k^2 \rho_e V_e A_{fs}$$

$$\dot{m}_{ss} = k^2 \dot{m}_{fs}$$

The final step in this analysis is using the similitude equations for total fuel mass and mass flow rate to create a similitude equation for the time of engine burnout. By dividing the total mass by the mass flow rate, our time of burn of can be calculated for the large scale and by similitude to the subscale model.

$$(t_{burnout})_{fs} = \frac{m_{fs}}{\dot{m}_{fs}}$$

$$(t_{burnout})_{ss} = \frac{k^3 m_{fs}}{k^2 \dot{m}_{fs}}$$

$$(t_{burnout})_{ss} = k(t_{burnout})_{fs}$$

The final phase of this analysis comes in the coasting phase. The velocity at the time of burn out for the both scales should come out to be the same in this idealized model. This conclusion derives itself in the fact that the acceleration due to thrust of each engine is so much greater than the acceleration due to gravity that the gravity term can be neglected. After the gravity term is canceled out, multiplying the acceleration of the rocket and the time of burn out cancels out the scaling factor thus the velocity of the subscale and full-scale should be the same at time of burnout.

$$\frac{T_{fs} - D_{fs}}{m_{fs}} \gg g$$

$$a_{ss} = \frac{1}{k} a_{fs}$$

$$V_{ss} = a_{ss} t_{ss} = \left(\frac{1}{k} a_{fs}\right) (k t_{fs}) = V_{fs}$$

$$(V_{ss})_{bo} = (V_{fs})_{bo}$$

The heights at burnout are very different for the subscale and the large scale. From the first equation below, the initial velocity of zero for both the full and sub scale. This causes the equation to become just the acceleration part and transforms it into the following equation.

$$\Delta h = V_i t + \frac{1}{2} a t^2$$

$$(h_{bo})_{fs} = \frac{1}{2} a_{fs} (t_{bo})_{fs}^2$$

$$(h_{bo})_{ss} = \frac{1}{2} \left(\frac{1}{k} a_{fs}\right) (k t_{bo})_{fs}^2$$

$$(h_{bo})_{ss} = k \frac{1}{2} (a_{fs}) (t_{bo})_{fs}^2$$

The last two steps of this the analysis comes from the combining the terminal velocity of the rocket body during the coasting phase with an equation for the apogee of the full scale and the subscale. This final equation gives a way in which height and engine data from the scale model test can be used to determine the coefficient of drag for the full scale.

$$V_{term} = \sqrt{\frac{2mg}{\rho AC_d}}$$

$$h_{apogee} = h_{bo} + \frac{V_{term}^2}{2g} \ln \left(1 + \left(\frac{V_{bo}}{V_{term}} \right)^2 \right)$$

$$(h_{apogee})_{ss} = k \frac{1}{2} (a_{fs})(t_{bo})_{fs}^2 + \frac{2m}{k\rho C_d} \ln \left(1 + \frac{V_{bo}^2 \rho C_d k}{2mg} \right)$$

3.4 Reflection

Building and launching Raider one was a great experience and proved to be extremely beneficial by verifying simulation methods, construction methods and identifying design aspects that can be improved and applied to the full-scale launch vehicle, Raider 2. The launch of raider 1 came with getting a member of the team a level 1 high power rocket certification, and other team members gaining valuable experience with the construction, assembly, testing, and preparation of high powered rockets. Some things that will be improved upon is using the E-Bay as a coupler for a section, using nylon shock chords with Kevlar leads to prevent the risk of burning and breaking the elastic chord. Due to the great success of the Raider 1 launch, we are moving forward with momentum to Raider 2

3.5 Recovery

3.5.1 Final Design Specifications

The recovery system in our rocket will have two main stages as it returns to the ground. The first stage will be activated right after the rocket has reached apogee by deploying a drogue parachute 2 feet in diameter. This drogue parachute will help reduce the terminal velocity of the rocket while not allowing the rocket to drift past the requirements set forth by NASA. Upon reaching an altitude of 700 feet the 16-foot main parachute will deploy reducing the descent velocity enough for a safe landing. After the rocket has landed we will locate the rocket from an onboard T3 GPS Tracking System provided by missile works and activate the rover deployment

sequence. At this point, the nose cone will be ejected by a small ejection charge and the rover will then exit the launch vehicle to begin the deployment sequence.

3.5.1.1 Parachutes

For our full scale rocket we will be utilizing a 2-foot drogue parachute and a 16-foot main parachute. When looking at our main parachute we went back and recalculated our minimum parachute diameter based of an updated mass, this was done using the same method of calculation as used in the PDR

Due to the minimum kinetic energy allowance and updated mass we would still need a 16-foot main parachute to comply with the requirement. With this we will be utilizing the 16-foot main parachute produced by RocketMan. This selection was made due to strong recommendations from our mentor along with research proving a very high reliability for larger rockets. Along with proven reliability we determined that the larger RocketMan parachutes proved to be much easier to pack than many of the other commercially available parachute of similar size. From this the 16-foot 1.1 rip-stop nylon parachute from RocketMan will be the main parachute for the full-scale rocket.

Looking at the drogue parachute we have to pay more attention to the maximum drift allowance and how different sized drogue parachutes would negatively affect our allowed drift. With a more finalized and updated mass we were able to run through the drift calculation again show in section 3.5.3.2 which lead us to choose a 2-foot drogue parachute. Again we will be going with the RocketMan parachute but we will be choosing 1.9 rip-stop nylon parachute as the added thickness will allow for an added safety factor in the drogue parachute.

3.5.1.2 Harnesses

For our recovery system we will be using a two part system. The first part will consist of shock cords which will connect the two separate sections once they separate in the air and a second woven harness that will be the connection point between the shock cord and the bulkhead.

Both of our shock cords will be 1 inch tubular nylon with Kevlar leaders by RocketMan. This option was outlined as the frontrunner in our PDR but was yet to be decided upon until we talked to our mentor and confirmed that they could support the forces that will be acting on our rocket for both main and drogue deployment. We will have two shock cords in our rocket, one for the drogue and one for the main parachute. The first separation stage will deploy the drogue parachute that will be directly attached to a 15 foot shock cord. On the shock cord the drogue parachute will be attached 5 feet from the aft section which will be closer to the electronics bay. With our current rocket design this 15 foot shock cord will be connecting our front most section, which houses the payload, and the aft section that contains the electronics bay and motor. With the payload being directly connected to the drogue shock cord we wanted the shock cord to absorb as much of the impulse as possible. In order to help maximize the amount of energy absorbed by the shock cord we are going to accordion the cord in 4 inch sections. We will take about 4 to 6 inches of material and fold it over itself 3 to 5 times and secure each bundle with a single wrapping of electrical tape. An example of this process can be seen in figure 3-26



Figure 3-26

This method of bundle will help add a shock absorbing ability to the shock cord as each individual section will need to be broken and hence energy that would have been transferred into the rover will be absorbed by the cord.

To attach the drogue shock cord to the bulkhead's and the airframe we will use the woven harness outlined in the PDR and above. This harness will be woven between two 3/8 inch eyebolts that are bolted to the bulkheads along with a set of fender washers which shall help reduce stress concentration on the bulkheads and ultimately to the airframe. For the woven harness we will be using a length of Paracord that will allow us to get 5 wraps through each eyebolt. Wrapping the

Paracord around multiple times will increase the tensile strength of the harness as it would act as a larger composite material. With the Paracord woven between the two eyebolts the harness itself will act more as a shock absorber like you would see in your car. This ultimately helps reduce the amount of stress each bulkhead sees and is further explained in section 3.5.1.3.

Then next step in the recovery system is deployment of the main parachute that will happen at around 700 feet above the ground. At this point there will be separation between the electronics bay and the motor housing which will be connected through the main shock cord. With this being one of the more important stages of recovery we are again going with the 1 inch tubular nylon shock cord with Kevlar leaders. The length of this shock cord will be significantly greater than that of the drogue parachute being 40 feet in length. We will again use the procedure outlined in figure (3-26) to accordion the shock cord taking 6 inch sections and folding them over each other taking up about 2 foot of material at a time and securing these individual section with a single wrapping of electrical tape. Once the shock cord is deployed and the parachute deploys, the impulse force traveling through the shock cord will have to break each of these bundles before it is able to reach the airframe greatly reducing the amount of force seen by the airframe. The final connection point between the shock cords and the bulkhead will be similar to that of the drogue but will utilize 4 separate 3/8 inch eyebolt evenly spaced around the bulkhead. Again we will be using a length of Paracord to weave a cross shape between the 4 eyebolts where we will require 6 wraps to get the requisite amount of strength in this component. After the harness is woven we will attach the shock cord to the middle most point insuring the strongest point of connection. An example of the woven drawing can be seen below in figure 3-27 where the black lines represent the Paracord and the red arrow represents the shock cord attachment:

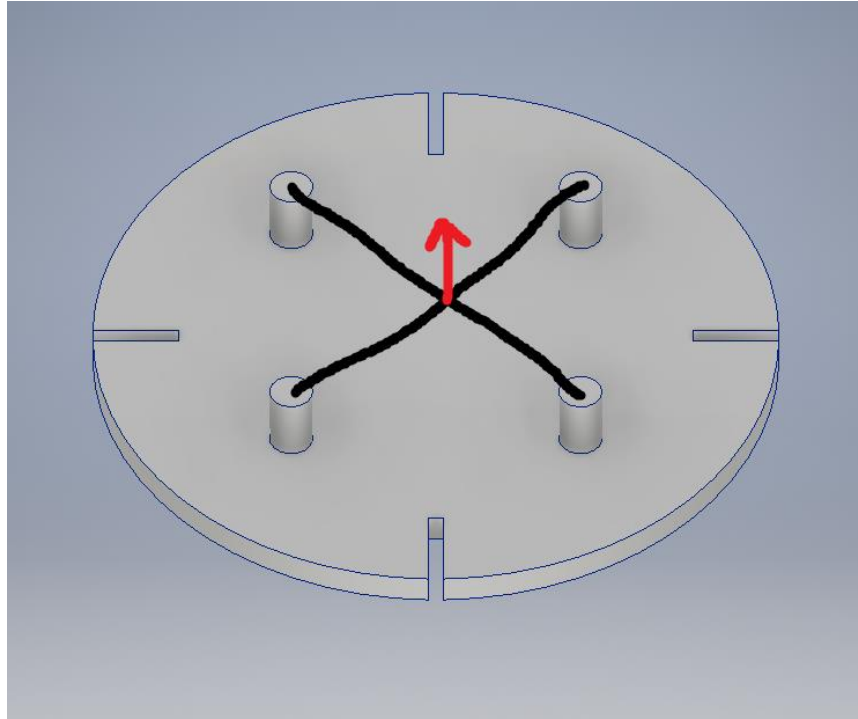

Figure 3-27

With the main parachute deployment being the largest force the rocket will experience it's important to fully understand all the forces in play at this point. The biggest risk we face during this point of recovery is some type of mechanical failure due to overload of a single component. In order to ensure that this does not happen we need to calculate the maximum force generated once the main is deployed. From our simulation data we can see that once the main is deployed we have a vertical acceleration of $631 \frac{m}{s^2}$ or $2070.21 \frac{ft}{s^2}$ we also know the mass of the aft and forward sections, that being $9821 g$ or $.67295 slugs$ and $7190 g$ or $.49267 slugs$ respectively. From here we can calculate the force on the aft most section, referred to as section from Newton's second law as shown in equations below:

$$F = \text{Force (lbf)}$$

$$m = \text{Mass (slug)}$$

$$a = \text{Acceleration } \left(\frac{ft}{s^2} \right)$$

$$F = ma$$

$$F = (.67295 slugs) \left(2070.21 \frac{ft}{s^2} \right)$$

$$F = 1393.148 lbf$$

And for the forward most section:

$$F = ma$$
$$F = (.49267 \text{ slugs}) \left(2070.21 \frac{ft}{s^2} \right)$$
$$F = 1019.930 \text{ lbf}$$

Here we can see that the maximum force of 1393.148 *lbf* acting directly on the bulkhead connecting the third section to the electronics bay. For design purposes we rounded up to 1400 *lbf* to help add a factor of safety while making the number easier to work with. Our shock cords are rated for 4200 *lbf* which gives us a comfortable safety factor of 3. This shows that the shock cords them self will be in a good position not to fail.

The final connection points will be in the nose cone where we have a bulkhead in the base of the nose cone that is connected to a bulkhead near the front part of the rover housing. The connection here will not be structural in any fashion and simply need to keep the two bulkheads connected while they are ejected. With this ejection charge only detonation after landing there will be a relatively low force acting through this shock cord. For this section we will utilize Paracord wrapped twice between the two connections. With the nature of this detonation we will have to make sure that some slack does exist within this connection point otherwise there would be no movement within this ejection system. This stage of ejection will not be connected to the rocket after ejection to help aid the deployment of the rover.

Further analysis of how these forces act on their respective bulkheads is carried on in section 3.5.1.3.

3.5.1.3 Bulkheads

Our rocket will have three separate ejection charges and 6 separate bulkheads to help contain these ejection charges within a certain volume. We have broken these contained volumes into three separation sections; the nose cone where we have a bulkhead in the bottom section of the nose cone and the top part of the rover housing; the drogue bulkhead's that will be placed on the aft end of the rover housing and the front end of our electronics bay; and the main bulkhead's that will be on the aft section of the electronics bay and the upper portion of the DACS system in front of the motor housing. Each of these bulkheads will be made out of a different material in

accordance to the forces they will see. Along with this the mechanical fasteners for all shock cord connections will be 3/8 inch eyebolts that are secured with a pair of nuts on either side along with a fender washer on the back side of the bulkhead to help more evenly distribute the stress each bulkhead will experience.

Due to the larger force this recovery harness will experience the biggest concern we have is minimizing the amount of stress that each bulkhead will experience. One simple way of doing this is to add more points of connection and help redistribute the stress acting on each bulkhead. An example proving that this process will help reduce the maximum stress each bulkhead is shown below in figure 3-28:

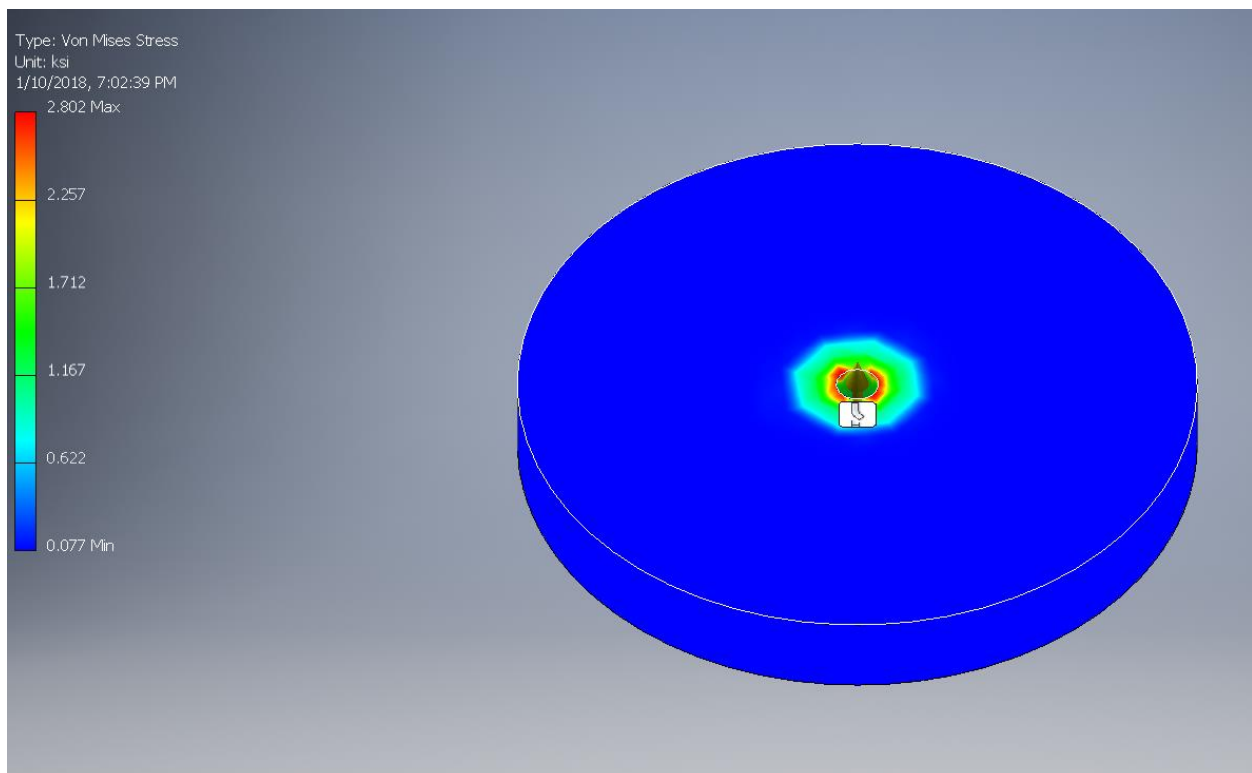

Figure 3-28

With one hole we can see a 2.802 ksi load where the same force applied to the same bulkhead with 2 holes can be seen in figure (3-3-3-2)

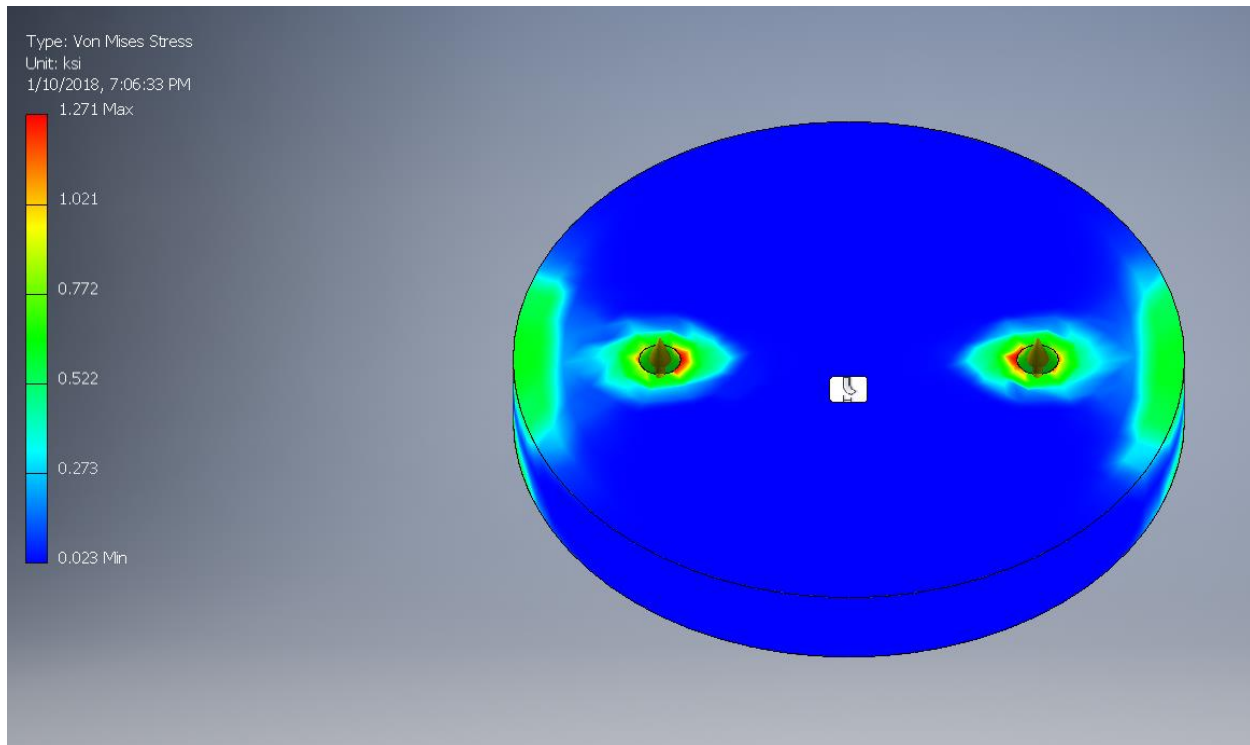

Figure 3-29

Here we can see that the maximum stress within the part will be 1.271 ksi.

3.5.1.3.1 Nose cone Bulkheads

The forward most bulkhead will be inside the nose cone right above the coupler of the nose cone. This bulkhead will be made of 1/2 inch plywood and then epoxied into place using G5000 in order to for an airtight seal and prevent the corrosive gasses from entering the compartment containing our long range receiver. This bulkhead will have to have five separate penetrations one for the 3/8 inch eye bolt where the shock cord will be connected. The remaining four connection will be for the ejection charges and their jumpers. We are unable to run the wire for the ejection charge through the bulkhead as it would not permit an airtight seal that's required for safe working order of the electronics in the nose cone. These ejection penetrations will be made with 1/16 inch all thread cut into long enough sections to allow for two bolts on either side of the bulkhead. The ejection charges themselves will then be attached secured between the pair of nuts on either side. Within the nose cone we will be attaching the bulkhead to the lip shown in figure 3-30

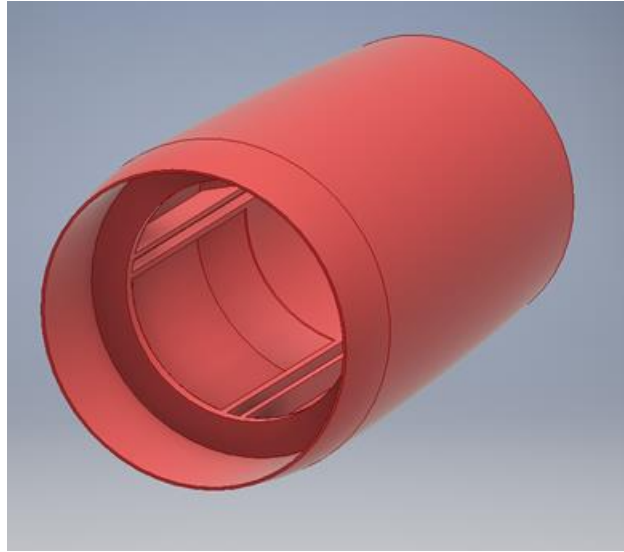

Figure 3-30

The other bulkhead in this system will be attached directly above the rover housing and secured directly to a 2 inch section of coupler. This bulkhead will only have a single penetration which will be for the 3/8 inch eyebolt that is connected in the fashion outlined above. This bulkhead will not be fastened to the airframe and will instead be removable and utilize a snug fit to secure it in place during flight. Upon ejection the nose cone will be forcefully removed and the momentum from the nose cone being blown off will take up all the slack and pull this aft bulkhead out after it. From here this aft bulkhead and nose cone will no longer be attached to the main airframe but still contain the GPS tracker therefore staying in compliance with the NASA requirements.

With the bulkhead in the nose cone being the only bit of separation between the ejection charges for this section and the receiver that will be setting off these charges, there is a high likelihood that the receiver could pick up stray signals that would set ignite the electric matches causing a premature ejection of the nose cone. With this high likelihood for error we will be including an electromagnetic barrier on this bulkhead to greatly reduce the probability of a premature detonation. For our electromagnetic barrier we will use a brass mesh that is attached directly to the inside of the bulkhead.

3.5.1.3.2 Main Bulkheads

The two bulkheads that will be used for the main parachute will have to be the strongest and most secure within the entire rocket as they will see the largest forces as shown above in section 3.5.1.2. For the forward most bulkhead in this system we will be fabricating it out of 1/4 inch thick G10 fiberglass as it has ample enough strength to support the 1020 *lbf* force. To get the 1/4 inch thickness we will be laminating two separate 1/8 inch thick G10 bulkheads as this will allow one of the two layers to be cut to the inner diameter of the electronics bay coupler while the other layer rests on the face of the coupler. This bulkhead will have a total of eight penetrations; four of which will be 1/16 inch in diameter and used as connection points for the ejection charges while the other four penetrations will be used as connection points for the recovery harness and its respective 3/8 inch eyebolts. This bulkhead will be torqued down to ensure that an air tight fit is achieved so the corrosive gasses released after a black powder detonation do not reach the electronics bay and damage the altimeters. This bulkhead is shown below in figure 3-31 in millimeters:

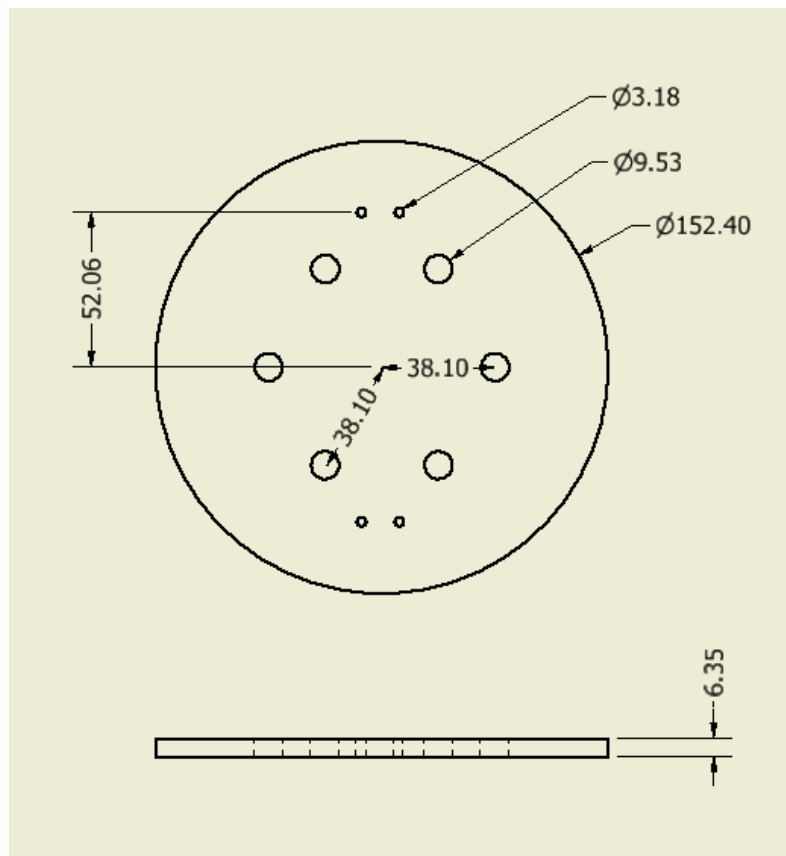

Figure 3-31

The aft bulkhead will be milled out of solid T6-6061 aluminum and attached directly above that DACS system where it will be connected to a set of reinforced fiberglass ribs with 3/16 inch machine hardware. This bulkhead design is shown below in figure 3-31:

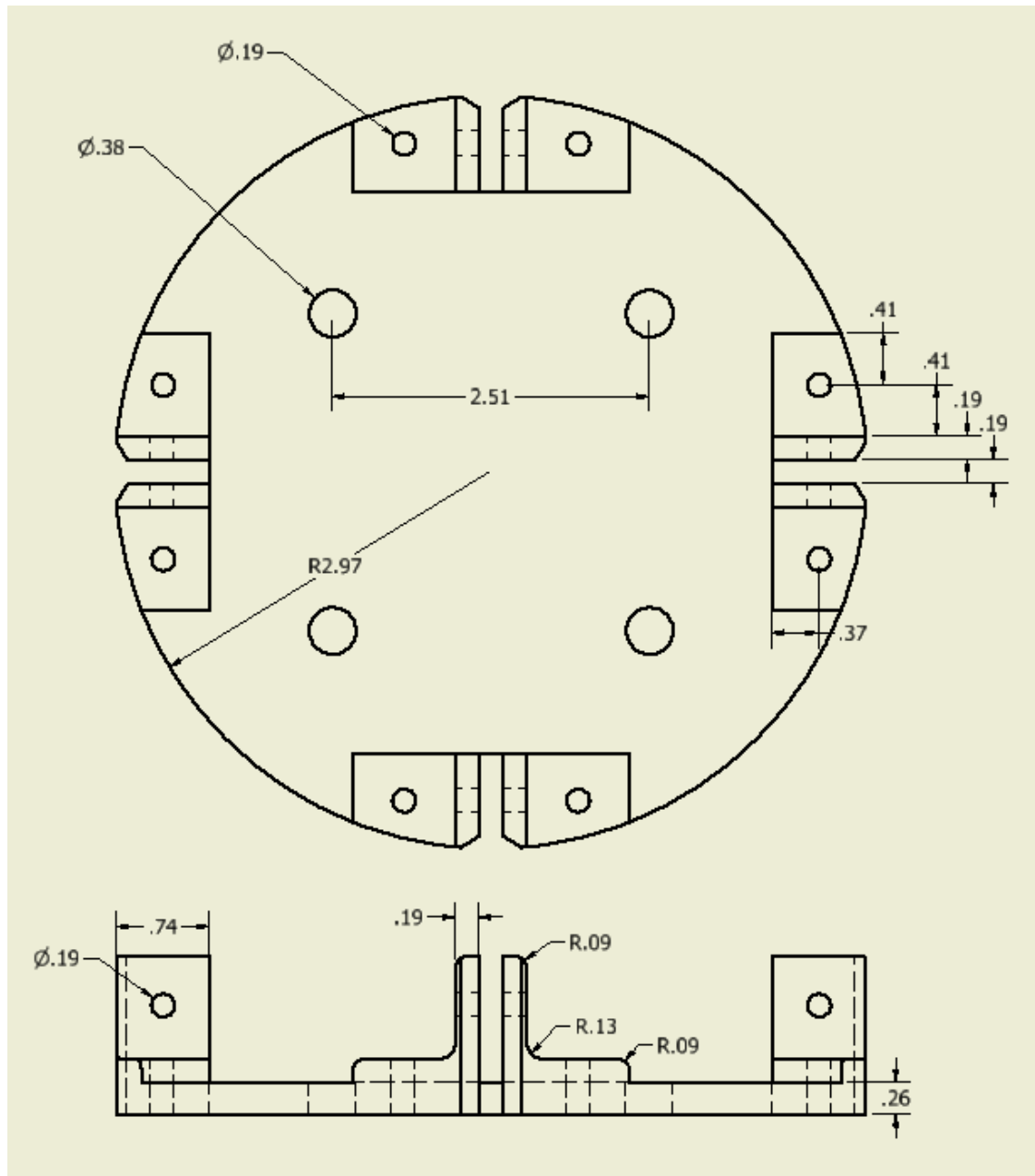

Figure 3-32

The decision the use aluminum was due to the increased safety factor of a solid metal bulkhead. With this specific member experiencing upwards of 1400 *lbf* we needed to make sure that it is properly secured to the airframe. To ensure a secure connection we will mechanically

fasten this bulkhead to the G10 ribs that will be exposed near the top of the DACS with a set of machine screw. To ensure that this single component could withstand the massive force that's applied to it we ran the bulkhead through a set of finite elemental analysis to determine its safety factor under load to be 2.14 which can be seen in figure 3-33:

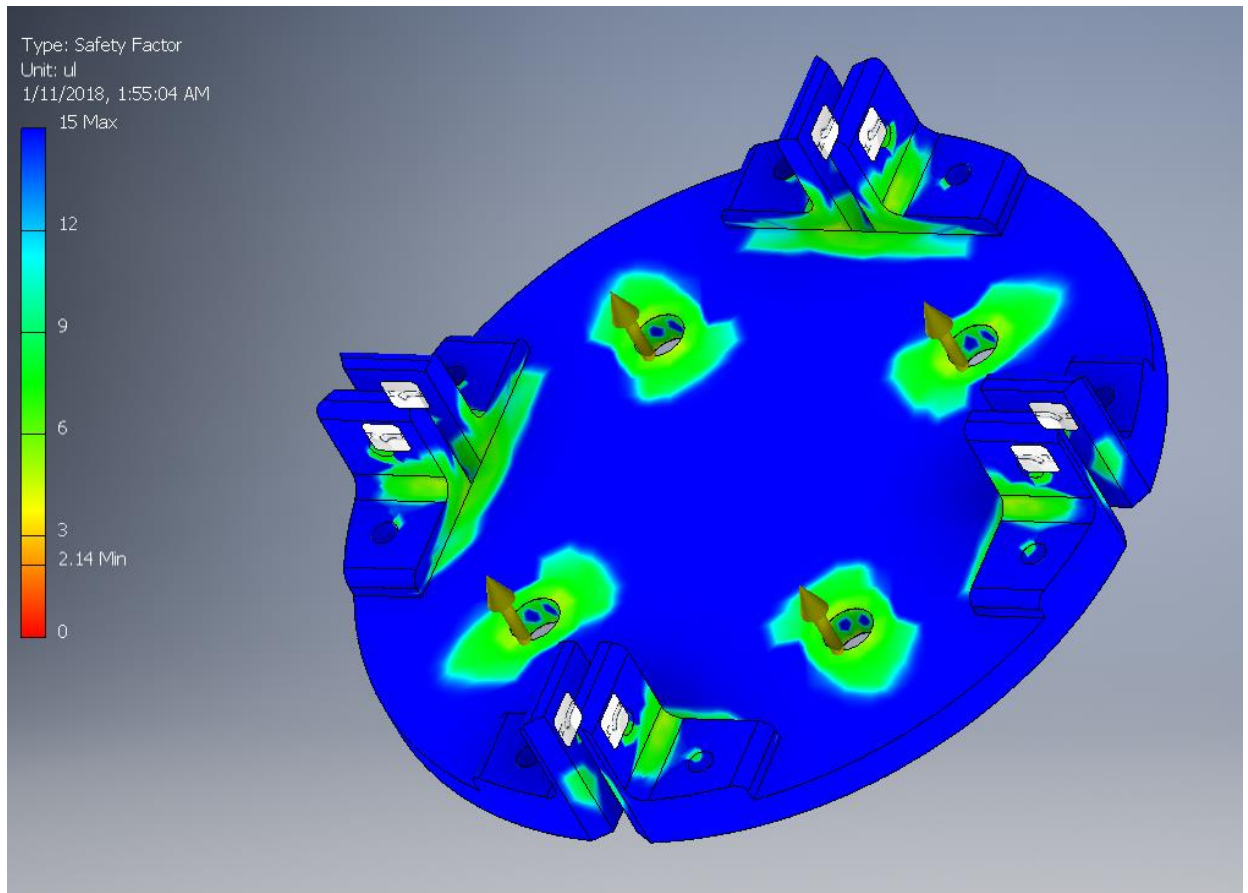

Figure 3-33

With the addition of our recovery harness the force experienced during flight will not be nearly as high and only improve our factor of safety. Again we will be looking for an air tight fit as this compartment will house the largest black powder detonation in our rocket. To help achieve this we will be constructing this part with extremely tight tolerances to achieve as snug a fit as possible. We will not be able to laminate this component directly to the airframe seeing how it will be the main point of access to the DACS subsystem.

With this set of bulkheads experiencing the greatest force they also have the highest risk of failure and therefore must be very carefully constructed and installed. Upon construction all aspects of these two bulkheads will be double and triple checked by the recovery team lead, vehicle team lead, and team safety officer. This will help reduce the chance of human error and work to ensure that these two components are securely fastened into the rocket.

3.5.1.3.3 Drogue Bulkheads

The final set of bulkheads in the rocket will be the connection points for the drogue parachute. These bulkheads will again be made of two separate materials with the one behind the rover housing being made of plywood and the bulkhead on the electronics bay made of G10 fiberglass. This bulkhead can be seen below in figure 3-34:

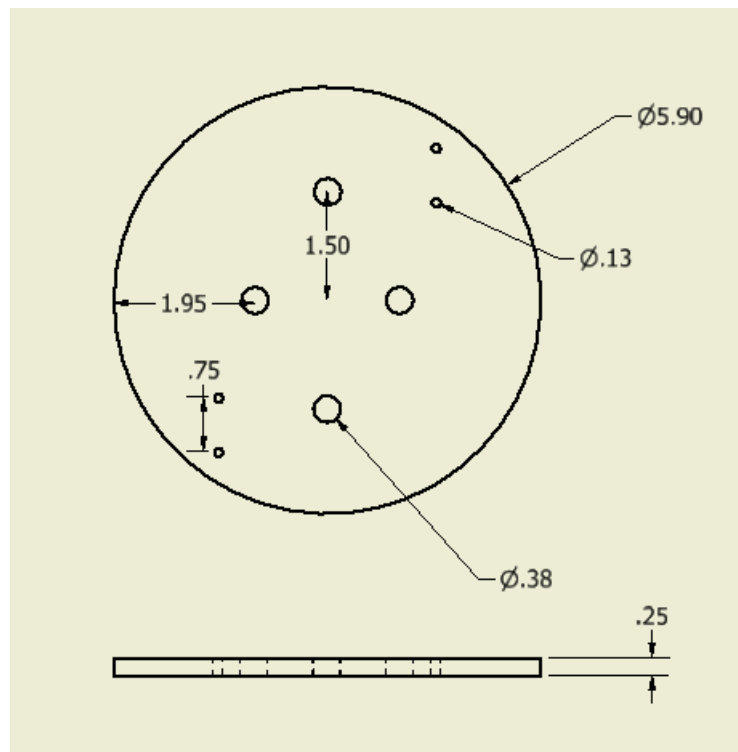

Figure 3-34

The bulkhead directly behind the rover housing will be made of $\frac{3}{4}$ inch thick plywood that will be epoxied in place with G5000 Rocketpoxy. This bulkhead will have two penetrations that will be for the mechanical fasteners used for the shock cord connection. These mechanical connections will be the standard $\frac{3}{8}$ inch eyebolts with nuts and washers.

The bulkhead that is on the forward end of the electronics bay will be made of G10 fiberglass 1/4 inch thick. This thickness will be accomplished by laminating two pieces of 1/8 inch thick G10 together and have a total of 6 penetrations. There will be two large penetrations for the shock cord hardware which will be the standard 3/8 inch eyebolts secured in the fashion outlined above. The four other penetrations will be the jumpers for the ejection charge. This will incorporate four 1/16 inch all-thread rods that are cut long enough to penetrate the bulkhead and have two small nuts on either side of the bulkhead. Two of these ejection penetrations will be used for the main ejection charges and two of them will be used for the backup ejection charges.

3.5.2 Final Electrical Design

3.5.2.1 Altimeter

For our altimeter we decided to go with the Perfectflight StratologgerCF which can be seen in figure (3-35) and was outlined in the proposal. This decision was made after doing research and looking at other team's previous USLI competitions and seeing that the StratologgerCF was a very popular among other teams in the past and widely known by our mentors as being a very reliable altimeter. The StratologgerCF is also ready right out of the box and does not need to be preprogrammed as the factory preset was the exact same as needed for our full scale rocket. Along with this, the StratologgerCF can be powered with a simple 9 volt battery which is large enough to provide power for the full 2 hours that is required by NASA.

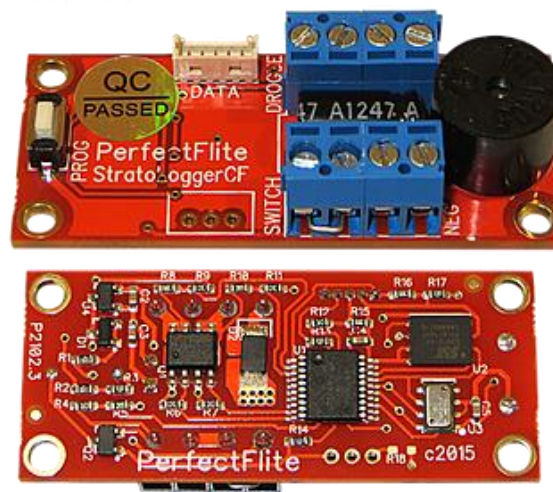

Figure (3-35)

When mounting the StratologgerCF we had to make sure there was clearance from the back of the altimeter and the sled we will be using. The altimeter required a 1/32 of an inch of space but we still had to insure that the altimeter was securely fastened. To accommodate both of these requirements we will use screws that are countersunk into the sled. With the screws coming up through the bottom of the sled we will attach a set of lock nuts on each screw so that the circuit board of the altimeter is resting on the locknuts and not directly on the sled giving us the required clearance between the pressure sensor and the sled. We will then lock the altimeter in place with a series of nuts to make sure it does not move during liftoff. The main altimeter will be programmed to deploy the main parachute at 700 feet with the backup system will be programmed to deploy the main at 650 feet.

To comply with NASA's requirement of redundancy we will be utilizing two separate altimeters, both of which will be Perfectflight StratologgerCF altimeters. Each of these altimeters will be completely separate from one another. This includes entirely separate power systems, arming switches, and ejection charges. One of the altimeters will be used for the main deployment while the other will be used as our backup ejection system along with being the dedicated NASA altimeter.

3.5.2.2 Ejection Charges

Deployment of parachutes will be initiated by the detonation of black powder charges in the parachutes' respective compartments. The drogue parachute main parachute compartments will be secured by #4 nylon "shear" screws. The detonation of the black powder charges will create an increase in pressure, which will shear the nylon screws and allow for the deployment of the parachute in the compartment. At the recommendation of our mentor, 30 psi is the pressure our charges will be sized to create.

The ejection charges will be packed into plastic centrifuge casings. The casings come in two sizes with enough space to pack 1.5 grams and .5 grams of black powder. Each casing (individual .5 or 1.5 gram canisters) will have an e-match run from the electronics bay, where it

will be connected to an anode and cathode. The e-matches will be triggered at the altitudes for their respective chute deployments.

To address our statement regarding the e-matches from the PDR, brought to our attention during NASA's review of the PDR. These e-matches will be wired in series, in order to ensure that the individual canisters, which make up the ejection charge, will ignite individually. This is to ensure uniform combustion, and mitigate the risk of incomplete charge detonation. The ejection charges will not be all set off at once.

Backup charges will also be placed inside of their respective compartments. These charges will be 1.2 times the size of the primary charges, and will be wired to our secondary altimeter. The backup charge will be detonated several meters after the primary charge, in order to ensure that parachute deployment occurs.

With regard to the nose cone ejection charge. The charge will be placed between the nose cone and payload bay. The charge is intended to propel the nose cone out and off, and pull the payload loose from the vehicle. These charges will be set off via radio transmitter manually. Similar to the drogue and main parachute charges, a redundancy charge will also be in place.

The mass of the black powder charges are given by the equation:

$$mass_{BP}(grams) = \frac{P_{req} * V}{\left(266 \frac{in * lbf}{lbm}\right) * (3307 R)} * \left(454 \frac{g}{lbf}\right)$$

The number shear screws has also changed, at the recommendation of our mentor. There will be a total of 3 #2 Nylon shear screws which will secure the drogue compartment. For the main chute compartment, a total of 4 #4 Nylon shear screws will be used. For securing the nose cone where it will eject away from the payload section, a total of 3 #Nylon screws will be used. The reduction in our overall screw count was to increase the probability of shearing, and reduce the probability of possible pressure buildup which could compromise the integrity of the airframe.

The volume of the compartments has changed since the preliminary design review, as well as the desired pressure, thusly the mass of the black powder charges has increased. The new compartment volumes and charge sizes are tabulated below.

Charge Sizes			
	Compartment Volume (in ³)	Charge Size (oz)	Charge Size (g)
Drogue Charge	278.2907 in ³	0.1520 oz	4.3088 g
Main Charge	500.9222 in ³	0.2736 oz	7.7559 g
Nose cone Charge	200.2676 in ³	0.1094 oz	3.1008 g

Potential risks regarding the ejection charges stem primarily from the use of explosive charges and the shear screws. It is vital to make sure that charges are properly sized, and also that shear screws will break. If the shear pins fail to break, pressure built up in the compartments could cause catastrophic damage to the vehicle and more importantly failure to deploy the parachutes. Failure to deploy the parachutes would result in the loss of vehicle, and mission failure.

3.5.2.3 Electronics Bay

The electronics bay will be at the heart of the recovery system and situated near the middle of the rocket during flight. The main structure of the electronics bay will be very similar to the sub-scale rocket in its general design having all the electronic components fastened to a plywood sled which is contained within a coupler and capped with two G10 bulkheads. The altimeters, batteries, and switches will all be mechanically secured to the sled with each altimeter independent of the other. The switches will be accessible from the outside of the rocket allowing the electronics bay to be armed on the launch pad without fully disassembling the rocket.

To construct the sled we will use a 1/8 inch plywood sheet connected to a pair of 1/4 inch diameter rods that run the length of the electronics bay and out each of the bulkheads. These two rods will be attached to the plywood by epoxying them on using a liberal amount of G5000 and assuring that it is fully cured before final electronics bay construction. The plywood sled will work solely as an attachment point for the different working components of the electronics bay. To ensure that the different components will not interfere with one another each separate system will be on either side of the sled to help reduce the chance of wire entanglement. The altimeters themselves will be attached with a set of countersunk screws coming up through the bottom of the

electronics bay that will be secured in place with a locknut which will also act as a spacer for the altimeter. The altimeter will then rest on these locknuts which will help by spacing the altimeter more than double the requisite 1/32 inch of space off the back of the altimeter. We will then secure the altimeter in place with a series of bolts.

The batteries used will be 9 volt Duracell and secured on the opposite side of the sled to help counter balance the total mass of the electronics bay and keep the center of mass near the central axis of the rocket. To secure the batteries we will drill a set of four holes two laterally and two in a horizontal fashion. The battery will then be placed inside these holes and zip-tied into place. We will then use a standard 9 volt battery connector making sure to run the wire through the bulkhead.

We will be using a screw switch to arm each altimeter which will be accessible from the outside of the rocket. In our sub-scale model we used a flip switch which proved difficult to arm once the rocket was on the launch rail. The screw switch will be much easier to access from the outside of the rocket with us being able to place the switch very close to the airframe. Alignment of the access ports will be crucial for success of the recovery system and to make sure that all the access ports are properly aligned we will be using a set of guide screws that will hold the coupler in place. This guide screw will be the first hole drilled into the coupler and secured before all other outside holes are made. This process will allow for a single alignment of the electronics bay once inside the rocket completely removing any possibility for improper alignment.

Another important aspect of the electronics bay is getting the proper amount of pressure holes drilled into the airframe. Because of the size of our rocket we will be using two pressure holes just large enough for a screwdriver to fit through. These holes will serve dual purpose as being the access port for the arming switches while functioning to equalize the pressure inside the electronics bay for accurate altitude readings.

To confirm that each altimeter system is armed we will wait, once the screw switch is closed, and listen for the series of beeps confirming proper functionality and wiring of all components in the electronics bay. Once armed each altimeter will begin to beep and these beeps

will be crucial to determine that we are ready for launch. With both altimeters being StratologgerCF's they report different numbers through a different number's of beeps as seen in figure 3-36:

0	Beep – beep – beep – beep – beep – beep – beep – beep – beep – beep
1	Beep
2	Beep – beep
3	Beep – beep – beep
4	Beep – beep – beep – beep
5	Beep – beep – beep – beep – beep
6	Beep – beep – beep – beep – beep – beep
7	Beep – beep – beep – beep – beep – beep – beep
8	Beep – beep – beep – beep – beep – beep – beep – beep
9	Beep – beep – beep – beep – beep – beep – beep – beep – beep

Figure 3-36

Once each altimeter is powered up it will report five numbers to us. The first number in the sequence will be the currently selected preset that the altimeter is programed to. This will be a number from 1 to 9. Second, there will be a two second pause followed by a three to four digit number that corresponding to the deployment height of the main parachute. Third, there will be another two second pause followed by the apogee of the last flight which will be a three to six digit number ranging from 160 to 103,500 feet. Fourth, there will be a two second pause followed by a series of repeated continuity beeps; one beep represents continuity within the drogue connection e-match; two beeps represents continuity within the main connection e-match; and three beeps represents both the drogue and main connection have good continuity. When arming both altimeters they will be programed to beep at different frequencies so we can differ between the two altimeters.

Both altimeters will need to be completely independent of one another and need to be wired accordingly. The following figure 3-37 shows how each of the two altimeters will be wired as its own independent system:

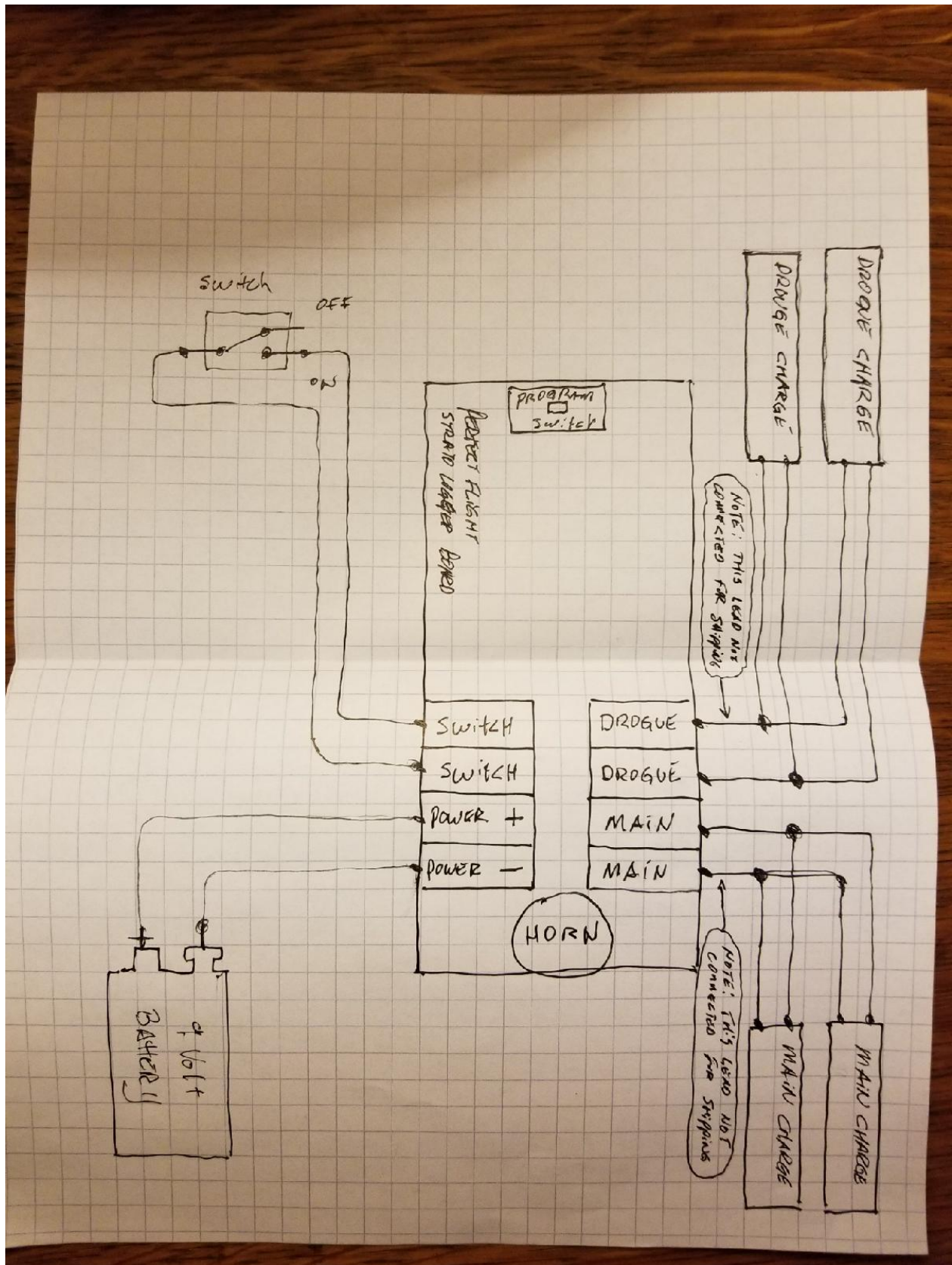

Figure 3-37

3.5.2.4 GPS Tracker

To keep in compliance with the NASA's requirement of having a GPS tracker we are planning on using a T3 GPS Tracking System provided by missile works. This part of our design was overlooked in the PDR but after speaking with our mentor he recommended this system due to the ease of use with android phones. With the relatively small nature of this component we will be able to fit in the nose cone where it will be secured to a 3-D printed sled within the nose cone. To arm this component we will access it from inside the nose cone seeing how the tip of the nose cone can be slid on and off with ease. We will use a simple flip switch that is positioned perpendicular to the direction of launch.

Operational Range Altitude	160,420 ft
Radio Operational Range	902 to 928 MHz
Range	9 miles
Operational Voltage	3.5 volts to 7.4 volts
Operational Current	@(3.7 volts) 175ma (rocket) / 70ma (base)
Weight	0.68 oz / 19.5 grams
Dimensions	1" x 2.075" / 25.4mm x 52.7mm

3.5.2.5 Long Range Transmitter

Once the rover lands we will need to start rover deployment from a predetermined location within in the launch field without being close to the rocket. With the maximum amount of drift being 2500 feet from the launch rail we will need to have a minimum operating range of 2500 feet. Another requirement for the transmitter is the need for multiple channels due to the redundancy needed for successful nose cone ejection. To meet these two requirements we chose to go with the SenMod Long Distance RF Switch Transmitter & Receiver. This receiver will allow for two output channels that are required for redundancy within in the system as specified by NASA. The specifications for this specific transmitter is given in the table below.

Remote Distance	1000 m
Operating Frequency	433 MHZ
Channel Number	2 Channel
Input Voltage	12 volts DC
Dimensions	35mm x 24.6mm x 10mm

This receiver will be housed in the nose cone attached to the 3-D printed sled along with all the power requirements and arming switch. With this specific component being part of the ejection sequence it will have to be armed once on the launch pad which will require access to this component from the outside of the launch vehicle. In order to achieve this, we will either use a magnetic switch or simply slide the upper most portion of the nose cone off and then reattach it before launch.

3.5.3 Recovery System Performance Prediction

3.5.3.1 Kinetic Energy Upon Landing

Kinetic energy of the modules was recalculated, to account for changes in mass made to the vehicle design since the preliminary design review. Mass was reduced from 11.36 lb to 10.591 lb in the nose cone and payload compartments, and increased from 28.993 to 29.726 lb in the electronics bay, dynamic apogee control system, and motor compartments. The overall change in weight was negligible, and simulation results were similar to preliminary design review results, with our descent velocity differing by approximately 3 ft/s during drogue deployment and 1.5 ft/s during main deployment. This, coupled with weight savings, and better weight distribution, did reduce the kinetic energy

Kinetic Energy			
Drogue Deployment			
	Section 1 (Forward)	Section 2 (Aft)	
Mass (g)	4804.000 g	13483.700 g	
Mass (lbm)	10.591 lb	29.726 lb	
Velocity (m/s)	36.641 m/s	36.641 m/s	
Velocity (ft/s)	120.-213 ft/s--	120.213 ft/s	
Kinetic Energy (J)	3224.836 J	9051.358 J	
Kinetic Energy (ft·lb)	2378.517 ft·lb	6675.939 ft·lb	
Main Deployment			
	Section 1 (Forward)	Section 2 (E-Bay)	Section 2 (Middle)
Mass (g)	4804 g	2385.700 g	9821 g
Mass (lbm)	10.591 lb	5.260 lb	21.652 lb
Velocity (m/s)	3.9762 m/s	3.9762 m/s	3.9762 m/s
Velocity (ft/s)	13.045 ft/s	13.045 ft/s	13.045 ft/s
Kinetic Energy (J)	37.976 J	18.859 J	77.636 J
Kinetic Energy (ft·lb)	28.010 ft·lb	13.910 ft·lb	57.261 ft·lb

The reduction in kinetic energy from the preliminary design review is compared in the table below. Sections highlighted indicate lower kinetic energy.

Kinetic Energy Comparison (PDR vs. CDR)		
Drogue Deployment		
	PDR Ek (ft·lb)	CDR Ek (ft·lb)
Section 1	2713.111 ft·lb	2376.180 ft·lb
Section 2	6924.145 ft·lb	6669.380 ft·lb
Main Deployment		
Section 1	36.990 ft·lb	27.820 ft·lb
Section 2	15.448 ft·lb	13.816 ft·lb
Section 2	70.993 ft·lb	56.873 ft·lb

Areas of potential risk with regard to kinetic energy, are generally associated with rapid increases in stress, thus resulting in a compromised airframe, potential shock damage to internal components (i.e. payload, electronic bay, D.A.C.S), as well as potential risk to the vehicle at large at touchdown. These risks are mitigated through the implementation of the aforementioned countermeasures, particularly through the reduction of descent velocity. At touchdown, with a velocity of 13 ft/s, the greatest kinetic energy is experienced in the aft section of the rocket (motor and D.A.C.S.) at 56.9 ft·lb.

Our analysis, given our simulated data, indicates that the rocket will behave within NASA's parameters for touchdown, and verifies that the recovery system will reduce the risk of potential damage to the vehicle to a point that is acceptable and safe.

3.5.3.2 Drift

Drift was calculated again to ensure that changes made since the preliminary design review, and to verify that expected drift has remained within 2500 ft of the launch site. Drift was calculated using the same equations as in the preliminary design review, given below.

$$\begin{aligned}
 h &= \text{change in altitude after chute deployment} \\
 v &= \text{descent rate} \\
 W &= \text{velocity of wind acting horizontally} \\
 \text{Drift} &= \frac{h}{v} * W
 \end{aligned}$$

Using simulation data, the change in altitude and descent rates were found. Wind speed was calculated across the gamut of potential wind speeds on launch day, with the maximum wind speed being 20 mph, the maximum windspeed for which Tripoli Rocket Association recommends for safe launch conditions. Expected wind speed is within the range 9-12 mph.

For the sake of calculating drift in nominal flight conditions, average descent velocity, given by $v_{avg,drogue}$ and $v_{avg,main}$, is used to calculate nominal drift, assuming nominal deployment of the chutes. In addition, deployed drift speeds would be used to calculate drift in abnormal flight conditions (i.e. instantaneous inflation of the parachutes and immediate jerk resulting in an immediate change in acceleration) which would maximize drift. The descent rates in this particular case are given by: $v_{deployed,drogue}$ and $v_{deployed,main}$. The average descent rate, deployed descent rate, and change in altitude for the drogue parachute stage are found to be 100.674 ft/s, -120.213 ft/s and 5274.081 ft, respectively. The average descent rate, deployed descent rate, and change in altitude for the main parachute stage are found to be 33.844 ft/s, 14.039 ft/s and 644.226 ft, respectively.

The first drift calculations use an average descent rate for the 2 parachutes, assuming normal deployment of the parachutes.

Nominal Drift (2 ft drogue and 16 ft main)					
Wind Speeds					
Wind Speed (mph)	0 mph	5 mph	10 mph	15 mph	20 mph
Wind Speed (ft/s)	0 ft/s	7.3 ft/s	14.7 ft/s	22 ft/s	29.3 ft/s
Wind Speed (m/s)	0 ft/s	2.2 m/s	4.5 m/s	6.7 m/s	8.9 m/s
Drogue Drift					
Drift (ft)	0 ft	261.9 ft	523.9 ft	785.8 ft	1047.7 ft
Drift (m)	0 m	79.8 m	159.7 m	239.5 m	319.3541 m
Main Drift					
Drift (ft)	0 ft	95.2 ft	190.4 ft	285.5 ft	380.7 ft
Drift (m)	0 m	29.0 m	58.0 m	87.0 m	116.0 m
Total Drift (ft)	0 ft	357.1 ft	714.2 ft	1071.3 ft	1428.5 ft
Total Drift (m)	0 m	108.8 m	217.7 m	326.5 m	435.4 m

The second set of drift calculations use an average descent rate for the 2 parachutes, assuming immediate inflation, and deceleration to terminal velocity with fully deployed chutes.

Immediate Inflation Drift (2 ft drogue and 16 ft main)					
Wind Speeds					
Wind Speed (mph)	0 mph	5 mph	10 mph	15 mph	20 mph
Wind Speed (ft/s)	0 ft/s	7.3 ft/s	14.7 ft/s	22 ft/s	29.3 ft/s
Wind Speed (m/s)	0 ft/s	2.2 m/s	4.5 m/s	6.7 m/s	8.9 m/s
Drogue Drift					
Drift (ft)	0 ft	219.4 ft	438.7 ft	658.1 ft	877.5 ft
Drift (m)	0 m	66.9 m	133.7 m	200.6 m	267.4 m
Main Drift					
Drift (ft)	0 ft	229.4 ft	458.9 ft	688.3 ft	917.8 ft
Drift (m)	0 m	69.9 m	139.9 m	209.8 m	279.7 m
Total Drift (ft)	0 ft	448.8 ft	897.6 ft	1346.4 ft	1795.2 ft
Total Drift (m)	0 m	136.8 m	273.6 m	410.4 m	547.2 m

The final set of drift calculations considers absolute maximum drift, which maximizes drift from the set of tables above. It is found that nominal deployment of the drogue chute followed by an immediate inflation, and deceleration, of the main chute maximizes the drift

Worst Case Drift (2 ft drogue and 16 ft main)					
Wind Speeds					
Wind Speed (mph)	0 mph	5 mph	10 mph	15 mph	20 mph
Wind Speed (ft/s)	0 ft/s	7.3 ft/s	14.7 ft/s	22 ft/s	29.3 ft/s
Wind Speed (m/s)	0 ft/s	2.2 m/s	4.5m/s	6.7 m/s	8.9 m/s
Drogue Drift					
Drift (ft)	0 ft	261.9 ft	523.9 ft	785.8 ft	1047.7 ft
Drift (m)	0 m	79.8 m	159.7 m	239.5 m	319.4 m
Main Drift					
Drift (ft)	0 ft	229.4 ft	458.9 ft	688.3 ft	917.8 ft
Drift (m)	0 m	69.9 m	139.9 m	209.8 m	279.7 m
Total Drift (ft)	0 ft	491.4 ft	982.8 ft	1474.2 ft	1965.5 ft
Total Drift (m)	0 m	149.8 m	299.5 m	449.3 m	599.1 m

Analysis of worst case drift, in 20 mph wind, yields a total drift of 1966 feet, a distance under the specified 2500 feet. Potential risk factors which could contribute to a larger than expected drift include: premature detonation of ejection charges, immediate inflation, and rapid deceleration, of either parachute, wind gradients, and possible updrafts.

To mitigate the risk of premature detonation of ejection charges, altitude will be monitored constantly by a microcontroller and redundancy checks will be run in order to validate proper timing. With regard to immediate inflation of either chute, proper procedures will be followed when packing the chute in order to insure proper inflation. Updrafts are not an expected issue, as they are associated with inclement weather, which could potentially warrant unsafe launch conditions. Regarding this, and other potential wind gradients, a margin of error is built into our design to pad potentially unknown variables (i.e. wind speeds at altitude). Additionally, the descent rate during our drogue stage, mitigates potential risks of drift at altitude.

Intermediary analysis of simulation data, compiled with small scale test results indicate that our design will operate within the specified parameters.

3.5.3.3 Testing

Ground testing will be conducted to verify the functionality of all recovery systems. Ejection charges will be tested by securing the vehicle to the ground, with the required shear screws installed, parachutes and shock cables installed, and with the deployed end pointed upward. They will be remote detonated via a battery-powered ignition switch, which will ignite our e-matches in the vehicle a distance away. Ground testing of parachute systems will serve to test the structural integrity of our bulkheads, the ability of our ejection charges to shear the nylon screws, and to ensure our packing of the parachute and shock cords is satisfactory. Ground testing of the nosecone charge will serve to validate our method of removing the payload bulkhead, and ensure that our ejection charge is sufficient in size to remove that particular bulkhead.

Ground testing will also be conducted on the altimeter to ensure that it will be capable of igniting our e-matches as they are connected in series. This will be used to validate our e-match arrangement and ensure that it will perform as expected on launch day. This will be done by igniting e-matches through the altimeter, rather than by switch.

3.5.4 Recovery System Success Criteria

Mission objectives for the recovery subsystem are given by NASA, and also consist of team derived goals for success.

Recovery Subsystem Mission Objectives			
NASA Objectives	Team Objectives	Design Consideration(s)	Verification
Successful deployment of drogue and main parachute	Successful deployment of drogue and main parachute within 1	Ejection charges are sized to generate sufficient pressure and shear pins are thin enough to ensure failure. Redundancy charges will be in place to further ensure deployment.	Visual verification at landing site of deployed parachutes.
Kinetic energy at touchdown less than 75 ft-lb	Kinetic energy at touchdown less than 60 ft-lb	Deployment of the main parachute is set at a point that will reduce our descent velocity to a safe range. Weight is also distributed across	Velocity at impact should be less than 15 ft/s

Touchdown within 2500 ft of launchpad	Touchdown within 1000 ft of launchpad	Deployment of the main is low enough to reduce drift caused by low descent velocity.	Visual and physical confirmation
Successful deployment of payload package within 10 ft of		Charges will be placed in the nose cone and will pull the payload bulkhead from the vehicle's airframe. Energy should be enough to remove the bulkhead, but not so much as to damage the payload.	Successful deployment of the rover such that it is capable of fulfilling its mission parameters
	Final shock cord bundle intact after main deployment, to prove ability of shock cord to absorb energy.	Shock cord should absorb enough energy such that the final shock cord bundle remains intact.	Inspection of the shock cord at touchdown will provide visual verification of the state of the cord.
	Successful retainment of all bulkheads.	Epoxy fillets will be applied to the bulkheads to reduce stress concentrations and hardware will be used where necessary.	Successful deployment of chutes (no bulkhead separation) as well as visual inspection at touchdown.

4. Safety

4.1 Safety Procedures

4.1.1.1 Vehicle Safety

G10 Fiberglass will be utilized for the fins and the Dynamic Apogee Control System (DACs) flaps. When cutting, or shaving down this material certain safety precautions will be taken since it is deadly when shavings are inhaled. Everyone in the proximity MUST wear the proper PPE: disposable coveralls, respirators, gloves, and safety goggles. The area will be removed of any shavings before removing PPE and continuing any other work.

When handling any adhesives such as Epoxy, proper PPE will be provided on site and worn by those within a 6-foot radius. Epoxy will be used only for bonding parts together for the USLI rocket and will be given the appropriate time to dry. Epoxy will be stored on the bottom shelf of the flammable cabinet to compensate for any falling damage. Proper PPE consists of but not limited to: disposable coveralls and gloves.

Regarding rocket motors, they will be stored in the appropriate container and locked away in the flammable cabinet. These motors will only be used for our USLI rocket scaled down model and full-scale model. Lastly, these motors will be disposed of in the proper fashion.

E-match's will be used for ignition to ensure appropriate distance of personnel from the launch pad. They will be secured and locked away in the appropriate container in the flammable cabinet. E-match's will be tested and properly fixed into the rocket motor.

Wind tunnel safety: Only authorized personnel permitted to use and be in the area of the wind tunnel. This is done to avoid overcrowding. All personnel will wear the PPE provided by the National Wind Institute (NWI) department. All personnel will abide by the lab safety rules of the NWI department and only use this equipment for USLI research. According to the NWI policies, anyone who uses these facilities must attempt and pass the following tests:

- Shop/Studio Safety
- Safety Awareness
- Hazardous connections
- Laser safety

4.1.2 Payload Safety

Battery use and storage – Among the batteries we're considering, all of them are Lipo-batteries. Lipo-batteries must always be stored at a storage charge and never completely discharged during use. For this reason, we will check our batteries at the beginning of every design period to ensure the battery condition is maintained. A battery voltage checker will always be on site, which confirms the voltage across each cell and if they are balanced.

ESC use – The Electronic Speed Control is dependent upon what current the motors require to function at a given voltage. Otherwise, the ESC would shut off at a given value pre-programmed or overheat causing an electrical fire. Clearly, to avoid overheating is desired, so many cross referencing and testing our connections will be executed to guarantee proper implementations. The ESC will be stored away from any exposure to water to avoid short circuiting.

Electric Motor – Our motor is the control when considering purchasing electronics. When selecting a motor, we concern ourselves with the kv value and required current to perform at certain voltages. This current is then cross referenced with other electronics to avoid any overheating resulting in electrical fires. Electric Motors will always be stored in its provided casing in order to avoid dust collection and exposure to water.

4.1.3 Recovery Safety

Black powder: Will be utilized for the separation stages and the following safety measure will be followed by Space Raiders personnel. The flammable cabinet will be used for all black powder products of which will be ensured are sealed tightly. The cabinet will be securely locked inspected daily to upkeep cleanliness. When handling the black powder, the proper PPE will be provided and worn by all those within a 6-foot radius: disposable coveralls, gloves, safety glasses, fire

hydrant, fire-blanket, and a first aid kit. Quantities will be tested before implementing into the rocket itself. Tests will be executed safely by following these procedures: e-match ignition, all personnel at least 30 yards away, notified fire marshal and appropriate remote testing location.

Packing procedures: Only the safety officer and the Recovery Team Lead are permitted to pack the black powder discharging stages of the rocket. Appropriate PPE will be provided and worn. All other personnel will remain at least 30 yards away.

4.1.4 Personal Protective Equipment

- Eye Goggles
- Safety Glasses
- Wool/Nylon Fire Blanket
- Disposable Coveralls
- ABC Class Fire Extinguisher
- Disposable Gloves
- Leather Gloves
- First Aid Kit
- Plastic Tarp
- Breathing Mask

4.2 Reese Safety Policies

For all safety policies regarding personal and facility use at our workspace at Reese Technology Center please see Appendix C for the Raider Aerospace Society's operating policies.

4.3 Safety Budget

Equipment	Qty	Price	Total
Eye Goggles	14	\$1.20	\$16.80
Safety Glasses	12	\$1.85	\$22.20
Disposable Gloves	200	\$0.06	\$12.00
Disposable Coveralls	25	\$1.24	\$31.00
Breathing Mask	20	\$0.60	\$12.00
Wool/Nylon Fire Blanket	1	\$55.50	\$55.50
Poly Plastic Tarp	4	\$2.80	\$11.20
First Aid Kit	1	\$25.00	\$25.00
ABC Class Fire Extinguisher	1	\$60.00	\$60.00
			\$245.70

Figure 4-1

4.4 Warnings and Hazards

4.4.1 Recovery

4.4.1.1 Parachute

- Improper parachute preparation by folding and rolling can result in delayed or no deployment.
- Incomplete coverage of parachute with Kevlar fire cloth could result in minor to major burn damage to parachute or cords.
- Entanglement of cords could result in delayed or no deployment of parachute.
- Fraying cords during construction or packing could affect the performance of the drogue or main parachutes causing the rocket to fall at a undesired accelerated rate.

4.4.1.2 Bulkheads –aluminum, plywood

- Improper tolerance between inner dimension wall of the airframe and the bulk head will result in loss in pressure and potentially failure to separate.
- Placement of the bulk head is directly relative to the amount of volume needed in order for the ejection charge to separate the stages.
- Improper application of adhesives of bulk head to the airframe could result in loss of pressure and potentially failure to separate.

4.4.1.3 Nylon recovery harness

- If tied incorrectly or too loose, the knot could come undone under the heavy weight. This would result in disconnection between the main parachute and bulk head.
- If frayed during storage or packing, the nylon rope would possess a location of weakness promoting failure to withstand high tension forces.

4.4.1.4 Eye bolts and washers

- In the event the nut has become loose and was not included in the checklist, heavy vibrations could further loosen the seal between the nut and I bolt and potentially disconnect.
- Any washer other than a fender washer could provide a less than adequate area to distribute stress. Not including the washer completely would ensure the pre-load is applied to a smaller area and totally on the airframe which could result in damaging the airframe.

4.4.1.5 Altimeter

- When handling the altimeter, failure to use an anti-static band could result in grounding the electronics of the altimeter resulting in electrostatic discharge and short circuiting.
- Loose soldering could result in interruptions in the connection and complete disconnection and therefore, failure to deploy ejection charges and parachutes.
- Properly securing the Altimeter will prevent the solders from failing and vibrations from damaging or disrupting the altimeter.
- Failure to store or operate electronics of the altimeter from water could result in short circuiting and permanent damage.

4.4.1.6 Battery

- Failure to store batteries within the recommended range of temperature and prevent impact damage could result in hazardous battery performance.
- Failure to secure the battery to the sled of E-bay could cause disconnection to the altimeter and possibly battery damage.
- Loose soldering to the battery and incorrect polarity would prevent proper connections and failure to complete electronic circuit.

4.4.1.7 E-bay

- With the corrosive by-products of FFFFG ejection charges, allowing these gases to flow into the low-pressure chamber of the E-bay could potentially damage any electronics.

- Failure to follow specified directions for required quantity and hole diameters for the given altimeter performance could result in poor data produced and improper trigger of ejection charges.
- Failure to create complete seal and bond of bulk heads to the ends of the E-bay to the coupler could not only allow corrosive gasses to enter the E-bay, but could distribute the pressure of the ejection charges improperly and damage the electronics.
- Any damage to the sled prior or during flight will result in heavy vibrations to electronics and potentially disconnected seal along soldered points.

4.4.1.8 Wires

- When stripping wires, inability to ensure any exposed wires doesn't become interfered with due to being loosely secured could short circuit the connection.
- Inability to securely tighten any connections between wires and conductive materials would cause a disruption in the performance of the altimeter during flight and potentially failure to deploy ejection charges or parachutes.

4.4.1.9 Soldering

- PPE to be utilized includes pliers with heat resistant handles, an approved surface, and soldering syringe.
- Personal to solder will consist of the safety officer and vehicle team lead.

4.4.1.10 Shear pins

- Shear pins that aren't secured tightly could come loose during flight and result in the portions of the rocket partially deploying earlier than intended ending in many complications during flight.
- Shear pins that fail to shear due to too thick of a gauge would prevent separation forcing the rocket to go ballistic and damage the internal components with trapped heat.
- In the event the shear pins are not evenly distributed, the combined resistance to any shear force could prevent the pins from shearing and allowing the vehicle to separate.

- Incorrect placement of the shear pins along the body of the rocket could by-pass the whole purpose of the shear pins to prevent the rocket from separating pre-maturely.

4.4.1.11 Screws

- Failure to evenly distribute the screws, which prevent undesired separation, could result in material failure under stress. With the holes in the vehicle in such a close proximity, failure analysis proves this could be an area of weakness.
- Incorrectly placing the screws could result in completely defeating the purpose of the screws if it secured the wrong or no two sections of the rocket together.
- In the event screws of an inadequately small diameter were used, this could prove to be a problem if the ejection charges provided a force that exceeded that of the screws.
- The process in which the screws are secured along the walls of the rocket is done with placing threads for the screws to hold on to. Failure to provide these screws would result in the screws simply falling out during flight and prematurely separating during ascension.

4.4.2 Motor Preparation

4.4.2.1 Centering Rings

- Poorly secured and bonded centering rings could result in failure anytime during combustion allowing the center of thrust to fall out of alignment with the center axis line through the center of the rocket.

4.4.2.2 Encapsulating Foam

- During construction, the application of too much foam during the expansion process could result in overflow into the area for motor and centering ring placement.
- If applied while the coupler is not centered the center of thrust would be stuck in a position offset from the alignment with the center axis line through the center of the rocket.

4.4.2.3 Thrust Plate and Retaining Ring

- Relative to the screws mentioned in section 4.4.1.11, both the thrust plate and retaining ring are secured by screws and both are responsible for securing the rocket motor from moving into or out of a static position. Failure to ensure the tension of these screws or axially symmetric placement could result in an unstable rocket motor and center of thrust.

4.4.2.4 Motor

- Failure to store motors within the recommended ranges of temperature and prevent impact damage prior to launch could result in hazardous motor performance.

4.4.2.5 Motor Mount

- Inability to seal a snug fit between the casing and inner tube during construction could result in undesired vibration and variation from a constant center of thrust.
- Inability to ensure proper installation of the rocket motor into motor mount could prove extremely hazardous.
- Failure to properly install closures and retaining rings will alter the ability to contain the static position of the motor during ignition.

4.4.2.6 Fins Centering

- Failure to apply the appropriate application of epoxy between the fins and the airframe would result in potential fin flutter and the separation of a fin from the airframe.
- If the fins are not separated by an equal distance from one another, the flight of the rocket would be very erratic.

4.4.3 Setup on Launcher

- Failure to wait for approval from RSO and event staff to walk to pad with rocket could result in injury of surrounding personnel and disqualification from the competition.
- Failure to notify the area when tilting the launch rail and loading rocket could result in injury of personnel and damage to any equipment
- Failure to Check rail and rail button alignment could result in improper launch trajectory and launch velocity

- Failure to arm the primary or secondary altimeters will result in no deployment of ejection charges and data collection.
- Failure to recognize sequence of beeping which verifies the altimeter's connection to the drogue and main parachute will result in major confusion among the launch crew and inability to understand the rockets readiness status for launch.
- Inability to notify the surrounding personnel to clear the launch pad upon arming is extremely hazardous and could prove to harm any remaining personnel.
- Failure to wait for approval from the event administration for launch would result in a premature launch and inability to allow the surrounding personnel to prepare for launch.
- Failure to verify the safety of the airspace for launch could result in the collision with any air vehicles and loss of human life.
- Failure to secure payload and verify functionality with connections will cause undesired vibrations and possible disconnection and damage to electronics during flight
- Failure to check receivers are properly connected will result in no signal being received from team transmitter upon landing of payload
- Failure to ensure solar panels are properly connected and properly stowed away in order to be deployed upon landing could result in no deployment of panels or even the rover at all.
- Failure to ensure the battery is disconnected when connecting the motor igniter e-match could result in premature launch and major injury.
- Failure to ensure the rocket motor is secure on launch pad could create a very undesired erratic flight.
- Failure to inspect any overall configurations will increase the margin for error causing any number of mishaps .
- When packing drogue or main parachutes, failure to pack properly and protect from pyro charges will result in failure to deploy or poor operation.
- Failure to ensure drogue, main parachutes, and bulkheads are properly attached to shock cords with bowline knots could cause error in deployment.
- Failure to properly secure or ensure functionality of the DACS could result in poor implication during flight.
- Failure to ensure each altimeter is properly armed and connected properly will result in poor deployment or recording during flight.

- Failure to verify connections between e-bay and ejection charges could result in failure to deploy.

4.4.4 Igniter Installation

4.4.4.1 E-match

- Exposure to humidity could affect the performance of the e-match during ignition.
- Not confirming the quality of the e-matches in respect to the ability to light quickly could affect the effectiveness of the ejection charge.
- Completely forward and touching the grain
- Ensure igniter is not hot

4.4.4.2 Black powder charge

- An incorrect amount of black powder charge will result in either no separation deployment or the destruction of the rocket due to an over pressurized chamber.

4.4.4.3 Packing Insulation

- Inability to tightly pack insulation could result in a less than necessary explosive ejection. This could also result in air bubbles or gaps in the ejection charge which creates an uneven burn of black powder.

4.4.4.4 Electrical tape

- Failure to secure the electrical tape along the base of the ejection charge will cause the black powder to fall out through the base of the charge.
- Forgetting to tightly wrap the electrical tape around the exterior of the ejection charge lid could allow the ejection charge to unexpectedly open and spread along the interior of the rocket and failure to deploy separation.

4.4.4.5 Electrical Jumper

- Inability to ensure proper connection between the wire and nuts on the inside or outside of the e-bay would be deemed a failed connection and would prevent any ejection charge from activation.
- Failure to check the compression between the two nuts and single wire would result in disruption in the connection between the altimeter and ejection charges.

4.4.5 Troubleshooting

4.4.5.1 Epoxy options

- Choosing 15-minute epoxy where application calls for a more industrial form of epoxy would result in cracking along the bond and eventually no bond at all.
- Applying load prior to letting the epoxy enough time to properly set will weaken the bond and could potentially result in an improper bonding position.
- Failure to use proper PPE such as gloves and nearby disposable towels could result in bonding fingers together or damaging nearby equipment.

4.4.5.2 Room for error surplus materials

- In the event mistakes or miscalculations are to be made, a surplus of materials will ensure the construction keeps on moving forward with the encouragement of caution in future construction processes.
- Before applying any cuts or bonds to the actual rocket, testing on a remote piece of material will ensure proof of concept without the risk of ruining the project.

4.4.5.3 Spare screws and nuts

- If a screw is lost during the construction phase, there is a potential of structural failure as the rest of the system would have to compensate. This added stress could cause multiple screws to fail leading to early separation or complete failure.
- Failure to spot a spare screw or nut in the fuselage before it is completely assembled could result in internal damages. The electronics located in the e-bay could be impaired by an impact to the wiring or the Arduino itself.

4.4.6 Vehicle

4.4.6.1 Rail buttons

- Detachment of one of the rail button can result in the vehicle exiting the launch rail in a wrong direction. This poses a danger to those in the surrounding area as the rocket would be an uncontrolled projectile.
- Failure to secure can result in oscillations during flight and launch. These could lead to the failure of couplers if the force of the oscillations becomes too high.

4.4.6.2 Nosecone – 2 piece with slide abs plastic safety data sheet

- Failure to properly secure the two pieces of the nose cone together could result in detachment of a section causing aerodynamic instability and/or pieces turning into projectiles.
- Incomplete securing of nose cone to the vehicle body could result in an out of control flight path which can pose a threat to bystanders within the general vicinity.

4.4.6.3 Blue Tube Airframe and Couplers

- If a coupler does not extend part way down the inside of the airframe then there is a chance that the Blue Tube will fail under the stresses of flight. Failure to distribute forces over a large enough area could result in residual stress build up.
- A puncture in the Blue Tube could result in aerodynamic instability and airframe failure if puncture goes unnoticed

4.4.6.4 G5000 Rocket Epoxy

- Risk of shearing the epoxy due to the internal stresses the airframe will endure. Stresses would now have to be distributed on other locations where the supporting sections in the airframe might not be able to handle the increased load.

4.4.6.5 Aluminum Bulk Head

- If the aluminum bulk heads have any burs on them, then there is a chance of a shock cord being sliced in half during the separation phases. This could result in unattached sections tumbling to the ground and damaging itself along with bystanders.
- Failure to attach the aluminum bulk heads correctly can result in internal damage to the different sections that could get hit with shrapnel and the full aluminum plate.

4.4.6.6 DACS

- Uneven attachments of the flaps on the DACs could result in unstable, unpredictable flight.
- Pins which fall out due to oscillations during flight can result in control arms or lifting mechanism to fail on activation.

4.4.6.7 G10 Ribs

- Failure of the epoxy on the rib sections could result in loss of internal strength and durability over the duration of the mission.

4.4.6.8 Aluminum hinges (milled)

- Failure to apply thread sealer on the hinge pins could result in loss of pins and failure of the DACs system.

4.4.6.9 Drag flaps G10 (milled)

- Uneven attachments of the flaps on the DACs could result in unstable, unpredictable flight.
- Epoxy failure could result in fin detachment and eventual flight unpredictability.

4.4.6.10 Control arms stainless steel (dmls) metal 3d printed

- Defects occurring the in the material during the metal 3D printing could lead to part failure under the stress of the test and final launches.
- Improper assembling of the movement pins could result in loss of pins or improper control arm movements.

4.4.6.11 Fins (CNC routed)

- Failure of fins during the flight can result in the vehicle to no longer maintain proper stability and center of pressure leading to an out of control projectile in the worst-case scenario.
- Deflections made in the fin angles during transportation can result in the rocket flying off course. This poses a hazard to bystanders and those in the surrounding area.

4.4.7 Payload

4.4.7.1 Transmitter

- Failure to ensure batteries have full charge opens the chance to losing power during flight and inability to deploy parachutes or rover payload.
- Setting up the transmitter or switching to the incorrect frequency could result in inability to trigger actions at the appropriate times or even at all.
- Inability to purchase a transmitter that can operate within the appropriate range provided will result in failure to connect to the receivers and deploy rover payload.
- Failure to ensure each transmitter button send the appropriate signal to the correct action on the receiver could result in a incorrect order of ejection charges and deployment of rover payload.

4.4.7.2 Receiver

- Failure to ensure connection of the receiver to a power source will result in an inability to receive any signal from the team transmitter and no deployment of the payload or ejection charges.

- Failure to identify a common frequency between the transmitter and receiver will result in an inability to communicate any signal and no deployment of the payload or ejection charges.
- Failure to verify the given transmitter channels correspond with the correct channel output signals on the receiver could result in an improper combination of deployment between the ejection charges or payload
- Poorly secured receivers on both the payload and wall of airframe will cause undesired vibration and possible disconnection or damage to the receivers.

4.5 Section Checklists

4.5.1 Pre-Launch Checklist

- Inspect configuration**
- Drogue and main chutes are packed properly and protected against pyro charges**
- Shock cords are secured to bulkheads by a strong and sturdy knot**
- Motor is secure in rocket**
- DACS is properly secured and working functionally**
- Rectangular flaps move**
- Recognize readiness alarm/light for launch**
- Secured and mounted correctly**
- Wired correctly**
- Each altimeter is properly armed by an on/off switch**
- Inspect wiring to make sure there is no exposed wire or break**
- Inspect to make sure the altimeter goes through the beeping sequence when the switch is flipped on repeating 3 beeps different pitches**
- Check program of both altimeters**
- Altimeters are set to deploy drogue chute when the vehicle reaches apogee**
- Altimeters are set to deploy main chute when the vehicle reaches 700ft during descent**
- Rail buttons are secured to bulk heads by screw and tightened**
- Rail buttons are lined up with each other vertically**
- Securely tighten all screws**
- Payload is secured and functional**
- Rover is communicating proper connection to battery**
- Confirm bayonet is functional by locking and unlocking system**
- Payload is ready for deployment**
- Recognize readiness light/beeping for payload ejection charges**
- Recognize readiness light/beeping for solar panel deployment**

4.5.2 Launch Checklist

- Wait for approval from RSO and event staff to walk to pad with rocket
- Turn on rover to run program and wait for landing command
- Pack rover back in rocket and secure rover
- Nose cone is fitted snug and screws tightened
- Set up launch pad
- Tip pad over to lower rail
- Check rail and rail buttons to make sure everything is in perfect condition
- Slide rocket all the way onto the rail
- Tip pad up to raise rail and rocket
- Arm first altimeter
- Listen for the correct series of beeps
- Arm second altimeter
- Listen for the correct series of beeps
- Connect ELS to battery
- Clear the launch area
- Wait for approval from the event administration for launch
- Do final check for range being clear and clear sky
- Do not launch with wildlife in sky, airplanes, or into clouds
- Insert key into ELS
- Start countdown from 5
- Launch
- Remove key from ELS
- Disconnect ELS from battery
- Recover rocket and the rover

4.5.3 Payload Deployment Checklist

- Activate 1st channel via transmitter to activate payload ejection charge
- In the event of failed ejection, immediately activate the 2nd channel via transmitter and activate the backup ejection charge
- Activate the 3rd channel via transmitter to activate removing the pin to release the bearing for correct orientation
- Activate the 4th channel to engage the rover to drive out of the Rocket

5. Payload Criteria

5.1 Design Selection

All of the design alternatives previously mentioned in the PDR were carefully researched and critiqued in order to determine the best choice to pursue. The key parameters considered when narrowing down the choices include, but are not limited to, cost, efficiency, weight and space used. The following section explains the alternative that was selected and the reasoning behind the selection of the key components that make up the payload.

5.1.1 Rover Housing

The payload team determined that a cross-section exit with a rotating bearing housing is the most effective option for rover deployment. The rotating bearing housing provided a way to deploy the rover in any landing orientation and is shown in figure 5-1. The rover is constrained to the inside of the rotating bearing housing in such a way that it is stationary during launch, but will be able to rotate with the bearing housing and drive out of the cross-section exit after landing. The cross-section exit ensures that a blasting plate behind the nosecone can be used to make an exit for the rover instead of cutting a hatch in the airframe.

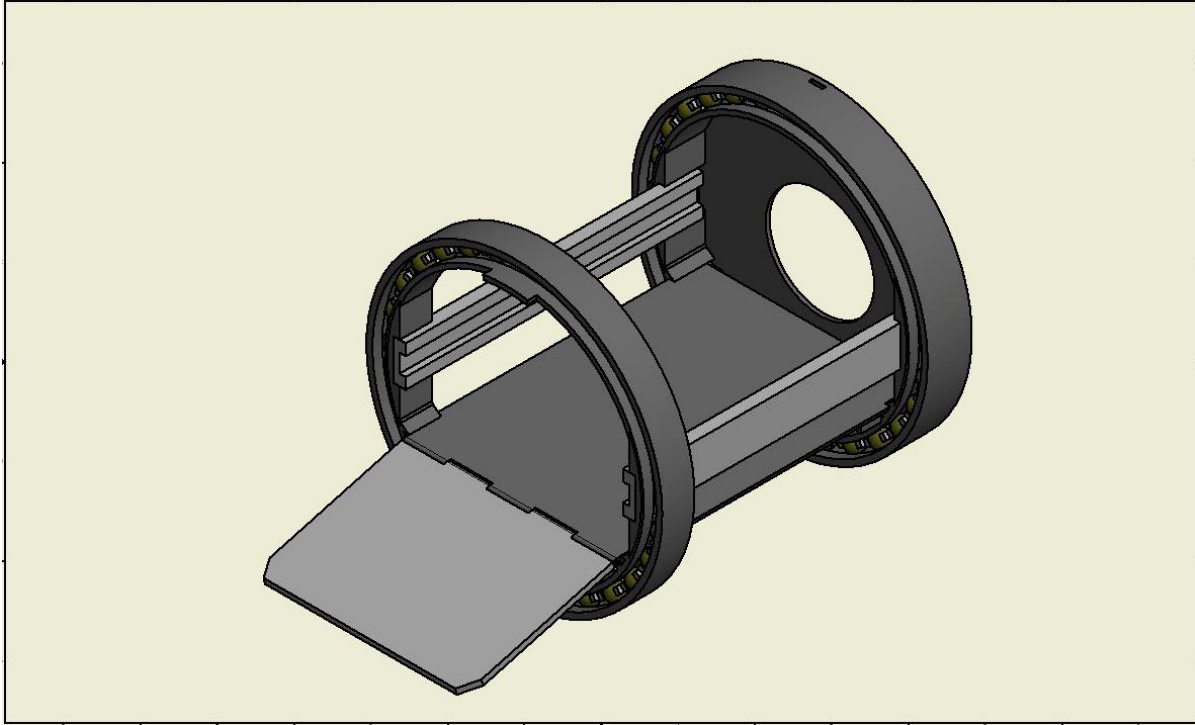

Fig. 5-1: Rover Housing Assembly

5.1.2 Rover Drivetrain Method

The goal of the drivetrain system is to have control of the rover's velocity and ability to climb over the small dirt hills. This led to our decisions for the drivetrain. The use of sensed in-wheel brushless motors will allow each wheel's rotational velocity to be the same over loose dirt. The ESC measures the rotational velocity of each motor, then varies the power sent to each wheel to maintain a constant rotational velocity across all four wheels. The motor will use a small pinion gear (C10) in sync with a larger spur gear (C11) on each wheel (C9) to increase the torque produced. The motors being used are designed for model airplanes, so they occupy a smaller volume. The motors are attached in the under carriage of the rover mounted on the side walls. Each wheel contains a large spur gear inside of it and acts as a cover, protecting the gears from interference from dirt and dust as shown by Figure 5-2. Each wheel contains a bearing allowing it to rotate freely around the axle pin.

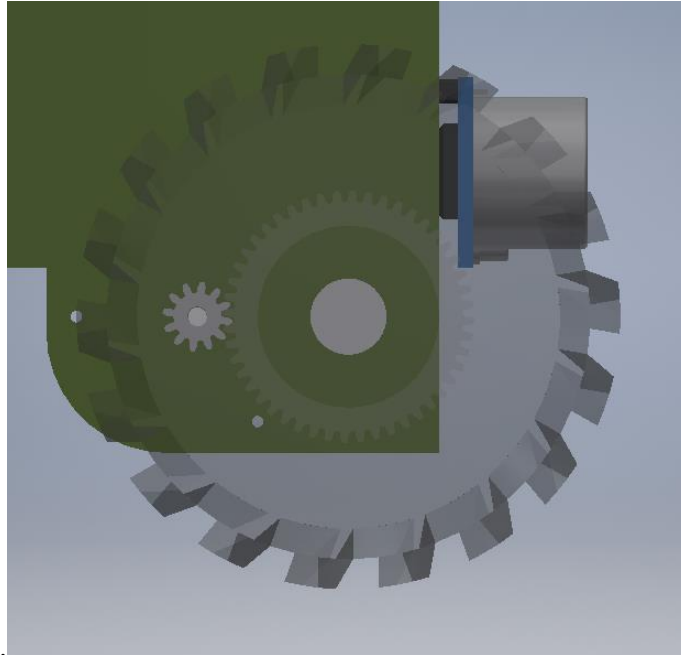

Fig. 5-2: The drivetrain for the front right wheel is shown inside of the wheel

5.1.3 Rover Steering Methods

The space inside the rover limits the options for a complex steering system. The goal for the steering system is to allow the rover to have as small of a turning radius as possible. This led the team in the decision to use the in-wheel motors independently to alter the movement of the rover without a traditional mechanical steering system. When the rover is travelling, and needs to turn, it will come to a complete stop. Then if it needs to turn right, it will rotate the front right wheel in reverse while simultaneously rotating the left rear wheel forward. This will allow for a very small turning radius, similar to the mechanics of a zero-turn lawn mower.

5.1.4 Wheel design

The wheels (C10) for the rover serve two purposes, to provide the rover with traction and house the drive train. The wheels are designed to rotate around a stationary axle pin (C8) by using a ball bearing placed in the center of the wheel. The 2.25 in diameter of the wheels adds to the rover's power to transverse uneven terrain. The rover wheel is based on off-road vehicles, which can be seen in the final design of the wheel shown in figure 5-3. The elevated chevron pattern yielded the best results in simulations by giving the rover the most traction in loose soil. The team added a slight chamfer to allow for a wider wheel that would be able to fit inside the rover housing.

This is necessary because the bottom of the wheels are not located directly in the center of the Rover Housing, so their allowed width is smaller than the nominal diameter of the Rover Housing.

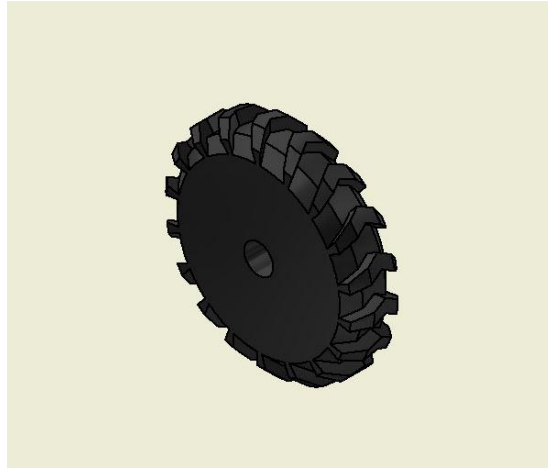

Fig. 5-3: Wheel design

5.1.5 Solar Panel Deployment

The hinge system of unfolding the solar panels was chosen for its simplicity and its ease of making the system self-locking. The current design that the payload team made uses two servos to control two different shafts that will rotate the solar panels similarly to a door hinge as shown in figure 5-4. The decision to use only servos, as opposed to a bigger motor with a gear system, was made because of the reduction in weight to the system and the compactness it offered. Research showed that a servo is ideal for accomplishing our task because servos operate at a low speed with a high torque, which eliminates the need for a gearbox like our previous design. This also reduces the weight of the deployment mechanism and reduces the overall cost of the deployment system which was a significant deciding factor when deciding when selecting this system. The servo is also easily controllable and is the most compact design we have made which was another significant deciding factor for the payload team. The chosen servos (Blue Arrow Micro Servo) have enough torque (0.65 kg*cm) to successfully rotate the solar panel plates.

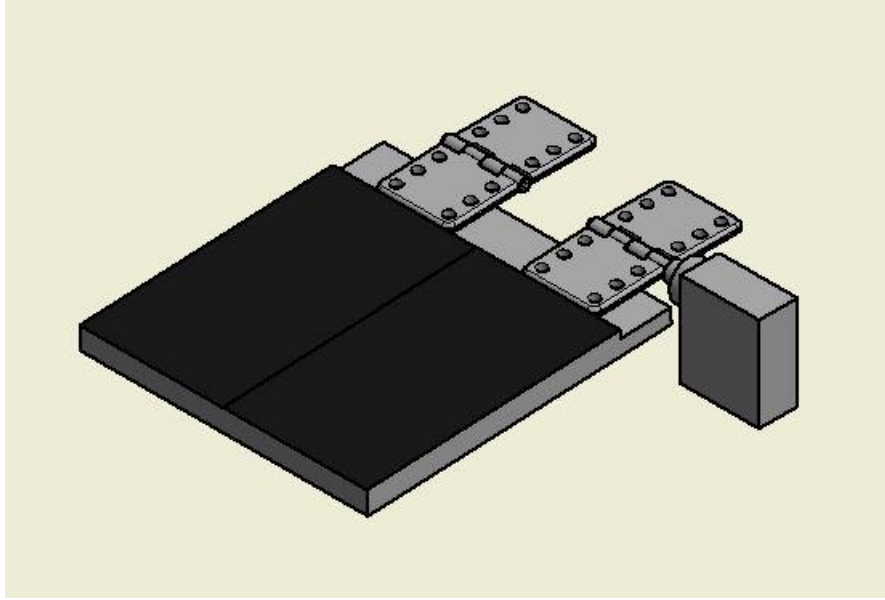

Figure 5-4: Solar Panel Deployment System

5.1.6 Bayonet fitting

The bayonet was chosen because of its simplicity and effectiveness, as well as the known fact that it is a design that has been used in the industry. The bayonet system is compact and offers simplicity because it only requires a single servo programmed to move between two settings. The team found that this was also a very cost-effective way to prevent the bearings from rotating midflight, potentially causing destabilizing effects. The parts that make up the bayonet system will be manufactured by the payload team and will have a “bone” like shape as shown in figure 5-5. This system is easily manufactured with a 3D printer and will support both the rover and the Rover Housing.

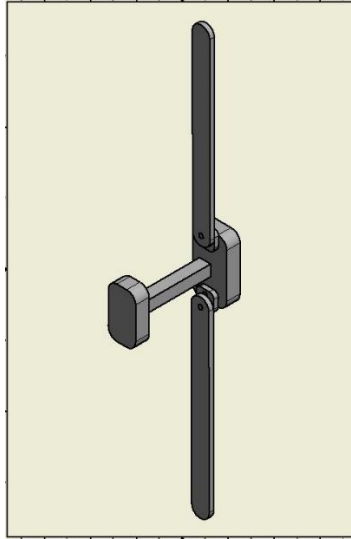

Figure 5-5: Bayonet Fitting

5.1.7 Rover Chassis

The rover chassis was selected to be 3D printed out of ABS plastic because of the desirable properties that ABS offers such as its light weight and high impact resistance. Texas Tech also offers free 3D printing, which helped to free up the budget for other areas. The chassis will be printed as seven separate pieces and will be secured together with a combination of adhesive and 2-56 screws. It is printed into seven pieces so that it is modular, which will allow simpler assembly of the electronic components that lie underneath or between different parts of the chassis.

5.2 Payload system design

The payload was carefully designed around critical parameters, such as the size and weight constraints, in order to accomplish the set tasks as efficiently as possible. The payload consists of multiple subassemblies and include: the rover chassis, the solar panel deployment, bayonet fitting, and the rear payload assembly. The following section will describe in detail each subsystem and the components that make up these assemblies. Due to the large amount of parts that are being designed and manufactured in house, the detailed drawings of these components can be found in the appendix (figures A-1 through A-38) at the end of this document.

5.2.1 Rover Chassis

The rover chassis will consist of seven different pieces that will be secured together by utilizing a system of “tabs” which will allow the use of 2-56 screws to join the pieces. Each piece of the chassis will be 3D printed and will be made of ABS plastic. This method of joining the pieces can be visualized in figure 5-6, which shows the partially assembled (not including the top or back panel of the chassis) and in figure 5-7, which shows all the pieces of the chassis. The size and features vary with each piece and combine to make an overall height 2.125 inches, an overall width of 2.9 inches and an overall length of 4.25 inches. The complex shape allows for several locations for electronic components and wiring.

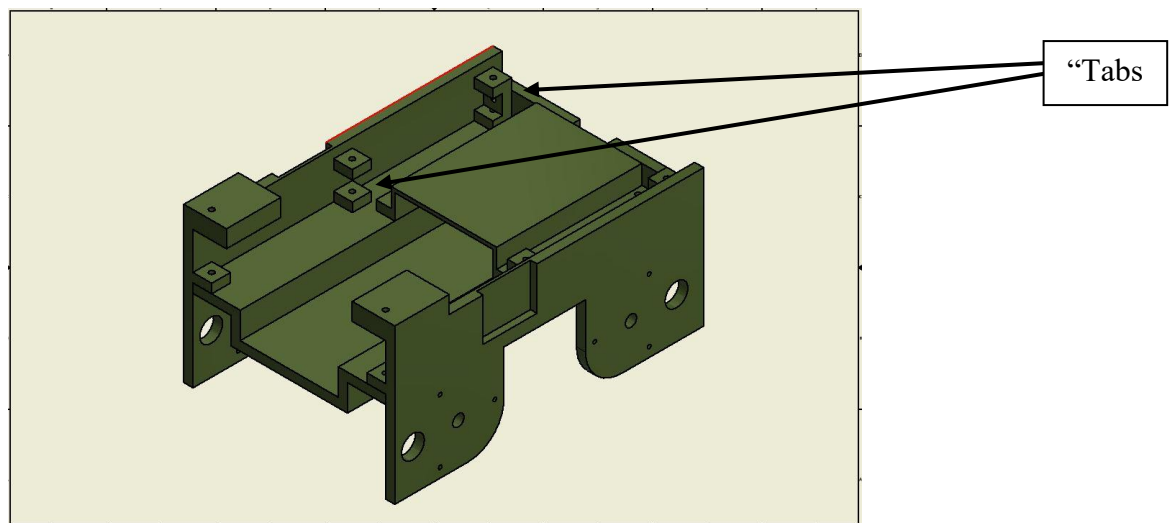

Figure 5-6: Rover Chassis

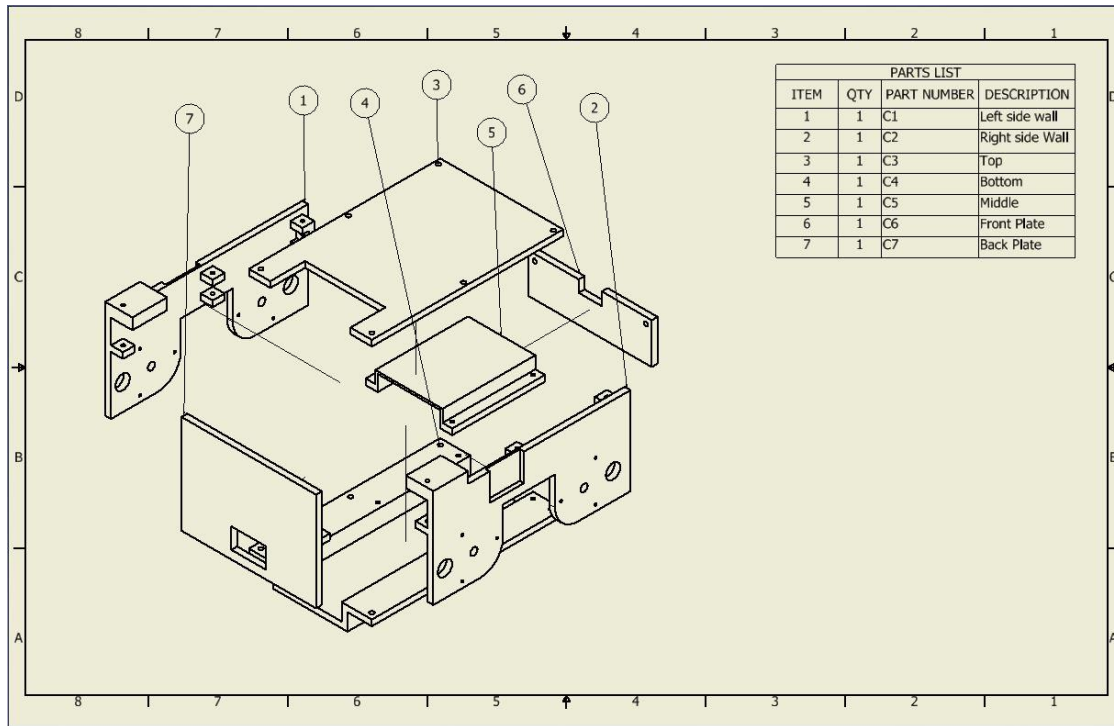

Figure 5-7: Chassis Assembly

This chassis will be driven by four C2024 Micro Brushless Outrunner motors that will be attached to the left and right side walls (C1 and C2, respectively), and will use an ultrasonic sensor, attached to the front plate (C6), in order to efficiently detect and avoid obstacles as the rover comes upon them. The top panel (C3) will act as a cover for all of the electronics, as well as support the solar panel deployment system and the receiver. The Arduino microcontroller will also be on the top of the rover, connected between the left and right side walls (C1 and C2). The ESC will be attached to the middle plate (C5), and all other electronics, (the battery, breadboard, altitude and temperature sensor, and the temperature and humidity sensor) will be placed on the bottom panel (C4). The electronic components will be secured to the chassis by either adhesive or screws that are provided by the manufactures. Figure 5-8 illustrates the layout of all of the electronics on the chassis, and Figure 5-9 shows an exploded view of the chassis and electronics. The back plate of the chassis (C7) will be used to secure the bayonet fitting, which prevents the rover and bearings from rotating during flight to avoid destabilization of the rocket. The bayonet fitting will be discussed in greater detail in a later section. The axles of the rover extend past the wheels and will slide along the rails of the housing that will act as constraints during flight and guiderails after landing.

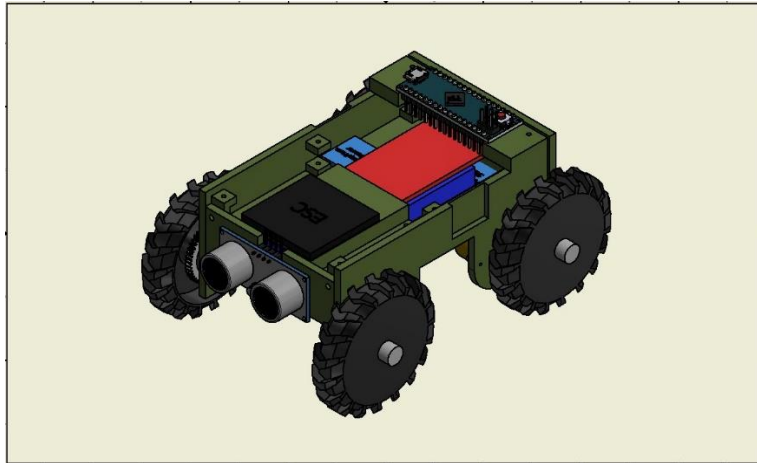

Figure 5-8: Chassis with electronics

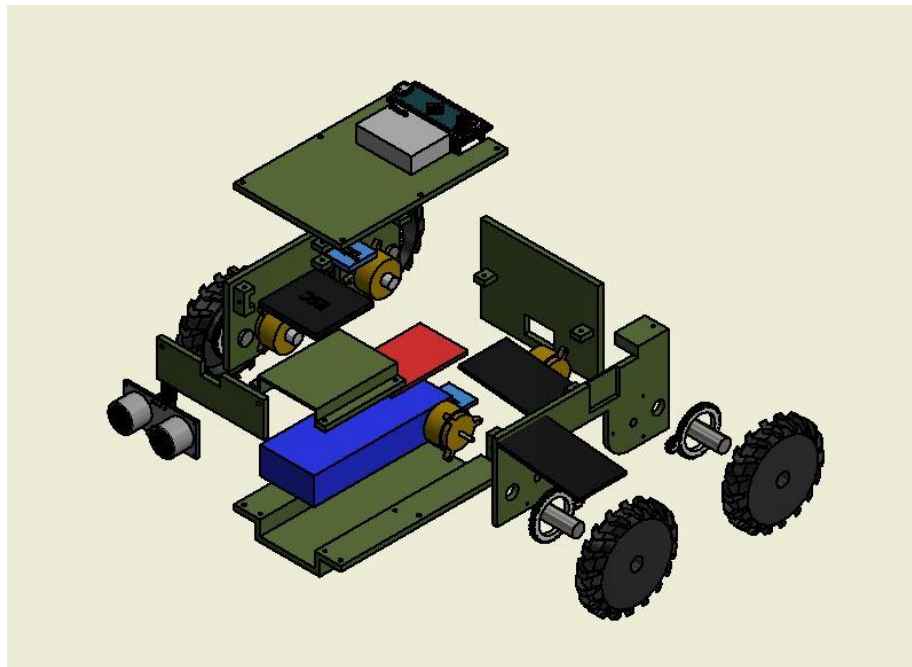

Figure 5-9: Chassis with Electronics: Exploded View

5.2.2 Wheel Design

The wheels will each house an individual drive train connected to its own motor. The spur gear (C11) will be attached to the wheel as seen in Figure 5-10. Each wheel will be 3D printed out of high-density ABS plastic with dissolvable supports. Two different versions of the wheel have been created (C9 and C10) to account for tread pattern on the left and right sides of the rover.



Figure 5-10: Spur gear attached inside the wheel

5.2.3 Solar Panel Deployment

The rover will have a total of five solar panels attached to it. One will be attached to the top panel of the rover chassis, and there will be two more attached to each panel that will unfold after the rover reaches its destination. Each of the two unfolding solar panel plates (SP1) are identical and will be made out of ABS plastic and will be 0.125 inches thick, 2.36 inches wide and 2.5 inches long. Two hinges will be used to attach the solar panel plates to the top panel of the chassis, and a servo will be used to rotate the pin in the hinges, effectively allowing the plates to unfold and allow all of the solar panels to access direct sunlight and this process is illustrated in figures 5-11 and 5-12. The servo has a torque capacity of 0.57 lb*in (0.65 kg*cm). The total weight of each plate and solar panel assembly is approximately 0.07 pounds (30 grams), and the center of mass is at approximately 1.5 inches distance from the servo. This corresponds to a worst-case torque of 0.10 lb*in (0.11 kg*cm). Therefore, the servos will be able to successfully deploy the solar panels.

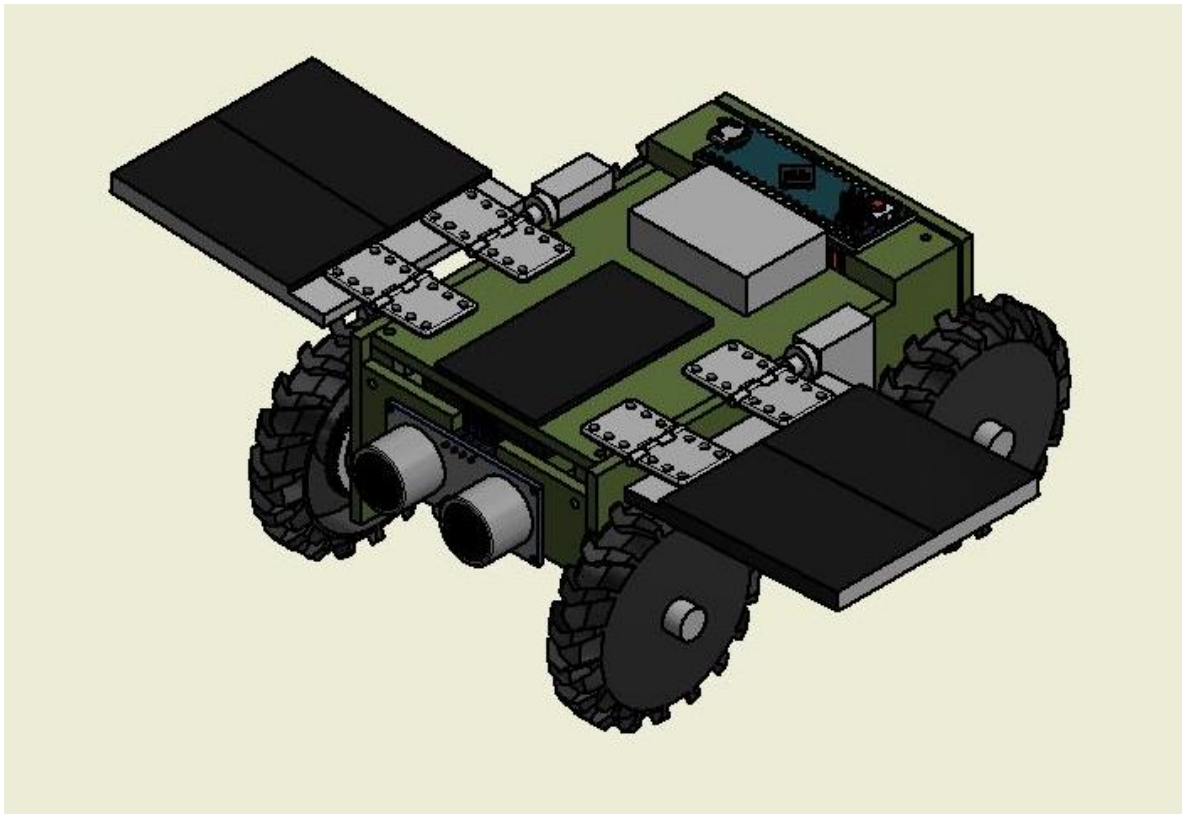

Figure 5-11: Solar Panels in the open configuration

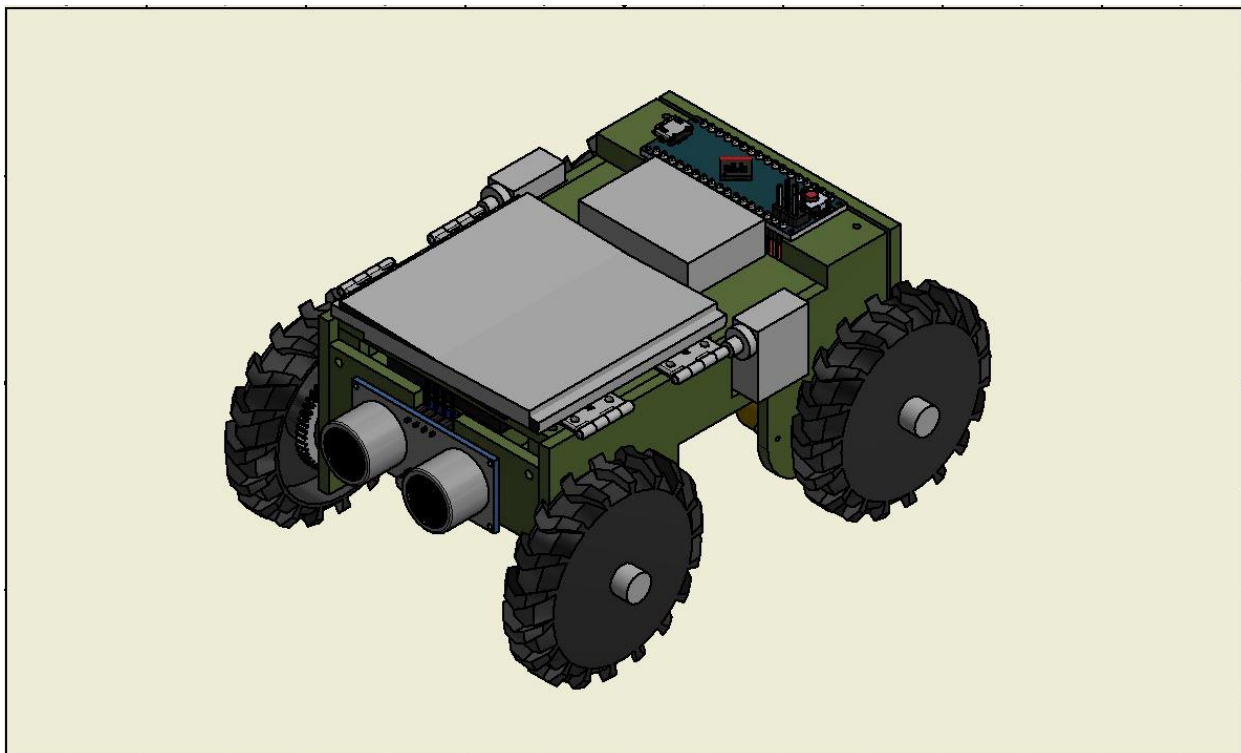

Figure 5-12: Solar panels in closed configuration

5.2.4 Bayonet fitting

The purpose of the bayonet is to prevent the bearings and rover from rotating for the duration of the flight in order to avoid the destabilizing effects that would occur otherwise. A connecting rod (B2) connects the bayonet fitting (B1) to the servo interface (B3) creating a “bone” like shape as shown in figure 5-5. The servo interface is attached to a servo which will control the orientation of the bayonet system. Figure 5-13 better illustrates how the bayonet fitting will fit together.

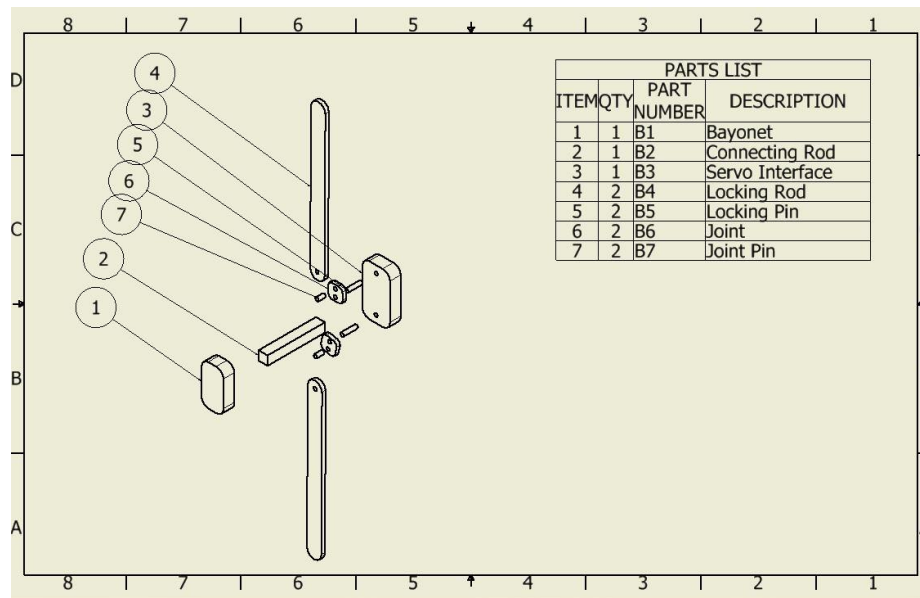

Figure 5-13: Bearing Fitting Assembly

Joints (B6) are connected to the servo interface which allow the locking rods (B4) to move in the vertical direction only. When the bayonet is in the horizontal position, it slides through the slot in the back plate of the rover and is considered in the unlocked position. Once it slides through the back plate, the bayonet rotates 90 degrees and is considered locked. At this point, the bayonet prevents the rover from moving toward the nosecone. In addition, the locking rods are inserted into the inner and outer races (RH.BB1 and RH.BB2), which prevents the rover housing from rotating. When the bayonet is rotated back to its original position after the launch, it releases the rover and the bayonet bearing.

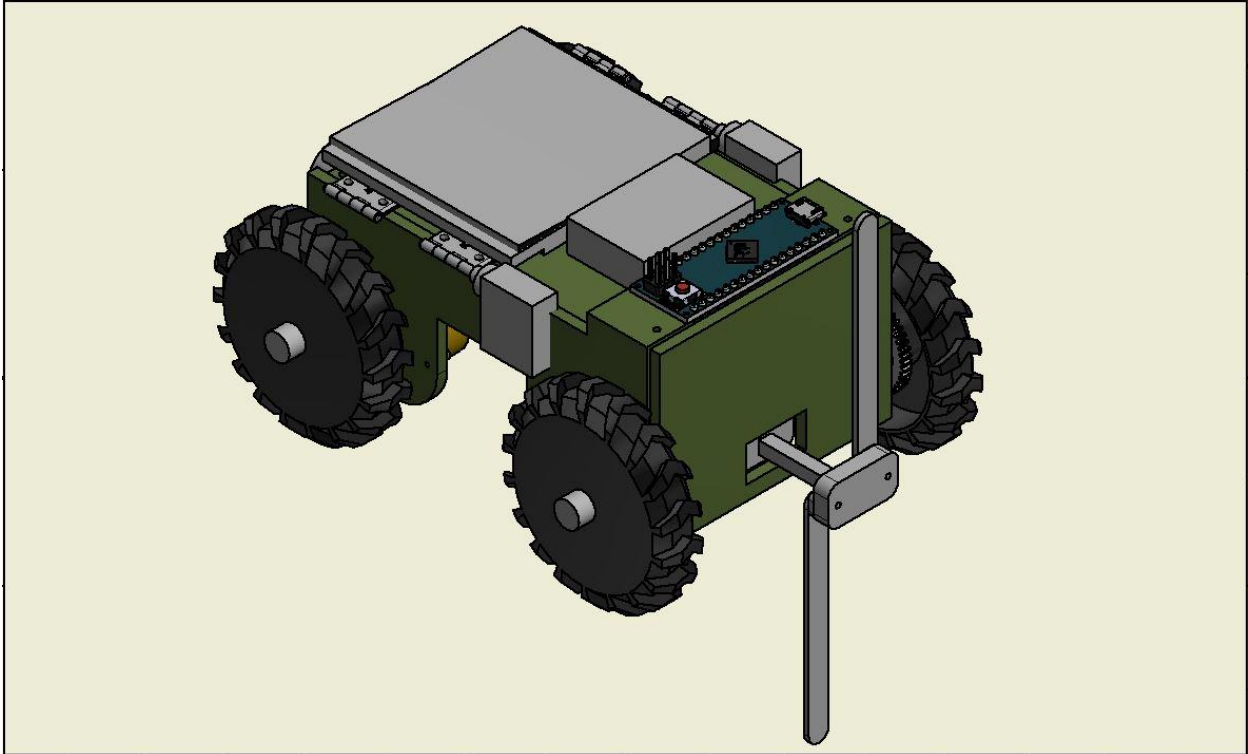

Figure 5-14: Bayonet in the unlocked position

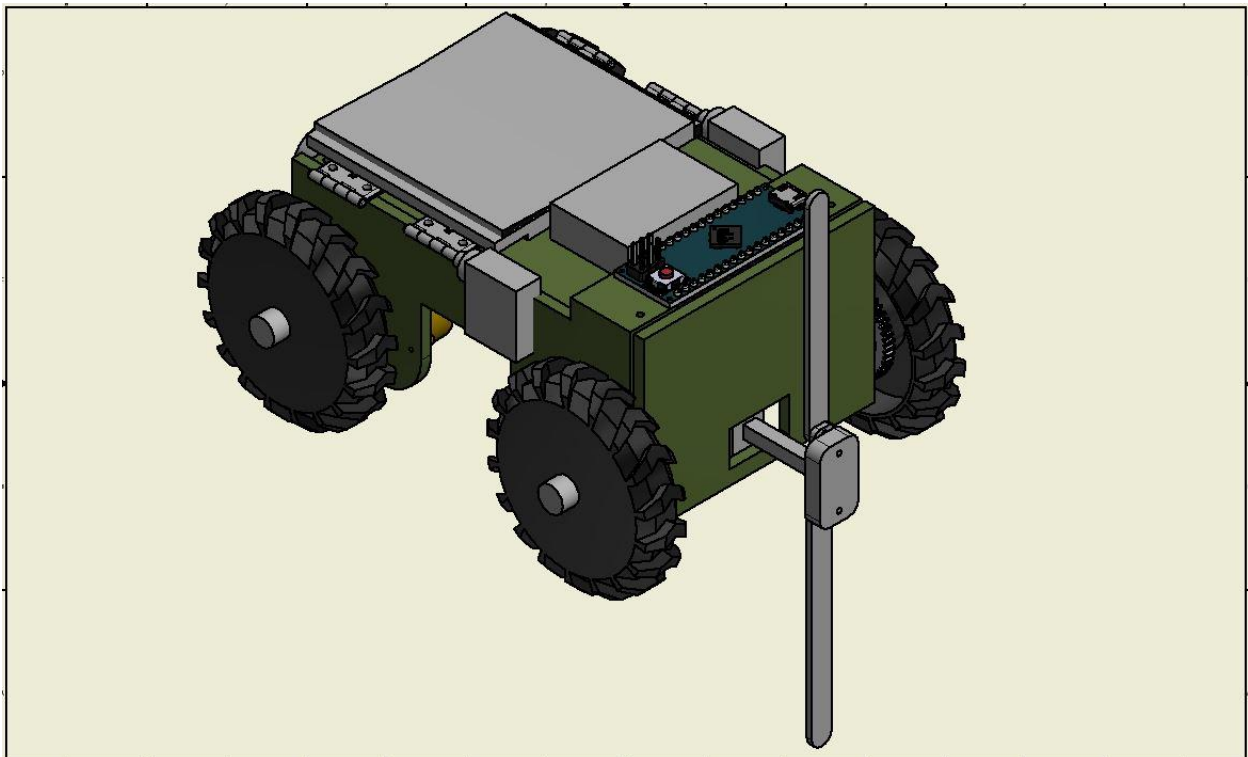

Figure 5-15: Bayonet in the locked position

5.2.5 Vehicle Housing

The payload housing consists of several components. There are two ball bearings, from here named the Exit Bearing (RH.EB) and the Bayonet Bearing (RH.BB), which correspond to the upper and lower portions of the payload section, respectively. The bearings will be secured to a coupling between two of the rocket sections with adhesive. Each bearing has several slots for the fitting of the Housing Rails (RH4) and Rover Platform (RH2). These components will be secured to their respective slots with adhesive. These provide constraints for keeping the rover in place as well as providing assurance that the bearings are rotating on the same axis. The Rover Platform has a hinge on the end, to which the Exit Ramp (RH1) is attached via the Hinge Pin (RH3). The Exit Ramp can rotate freely. During the launch, it is prevented from descending by the blast plate, which is directly above it. When the blast plate is pulled off by the black powder charges, the ramp will begin to fall as soon as the housing approaches the correct orientation. This is clearly shown in figure 5-16 below, which shows the assembly of the housing.

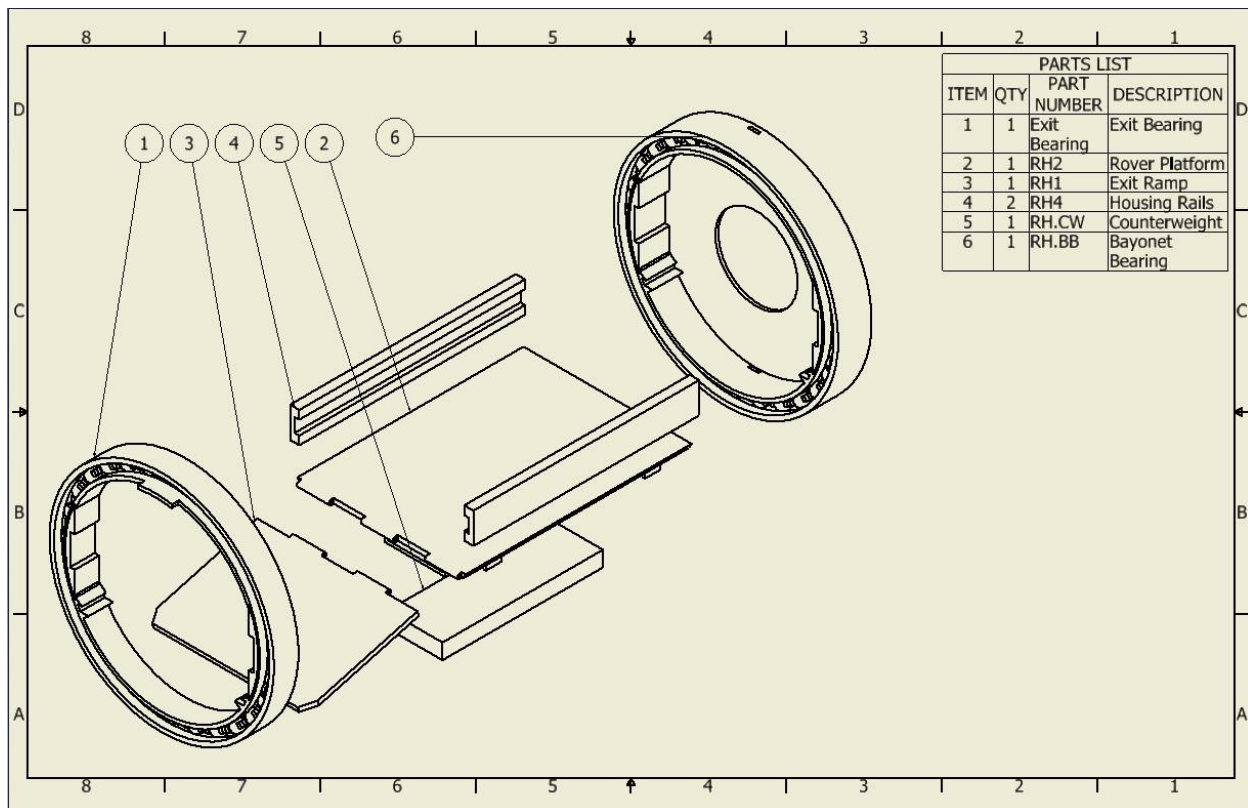

Figure 5-16: Rover Housing Assembly

The Exit Bearing has four components: the Exit Inner Race (RH.EB1), the Exit Outer Race (RH.EB2), the Bearing Cage (RH.BC), and the bearing balls. RH.EB1 has several slots in it to provide mounting locations for the Housing Rails and Rover Platform. RH.EB2 has no additional features. RH.BC supports each bearing ball and prevents them from grouping together. This also keeps the inner and outer race from becoming separated and this can be seen in figure 5-17.

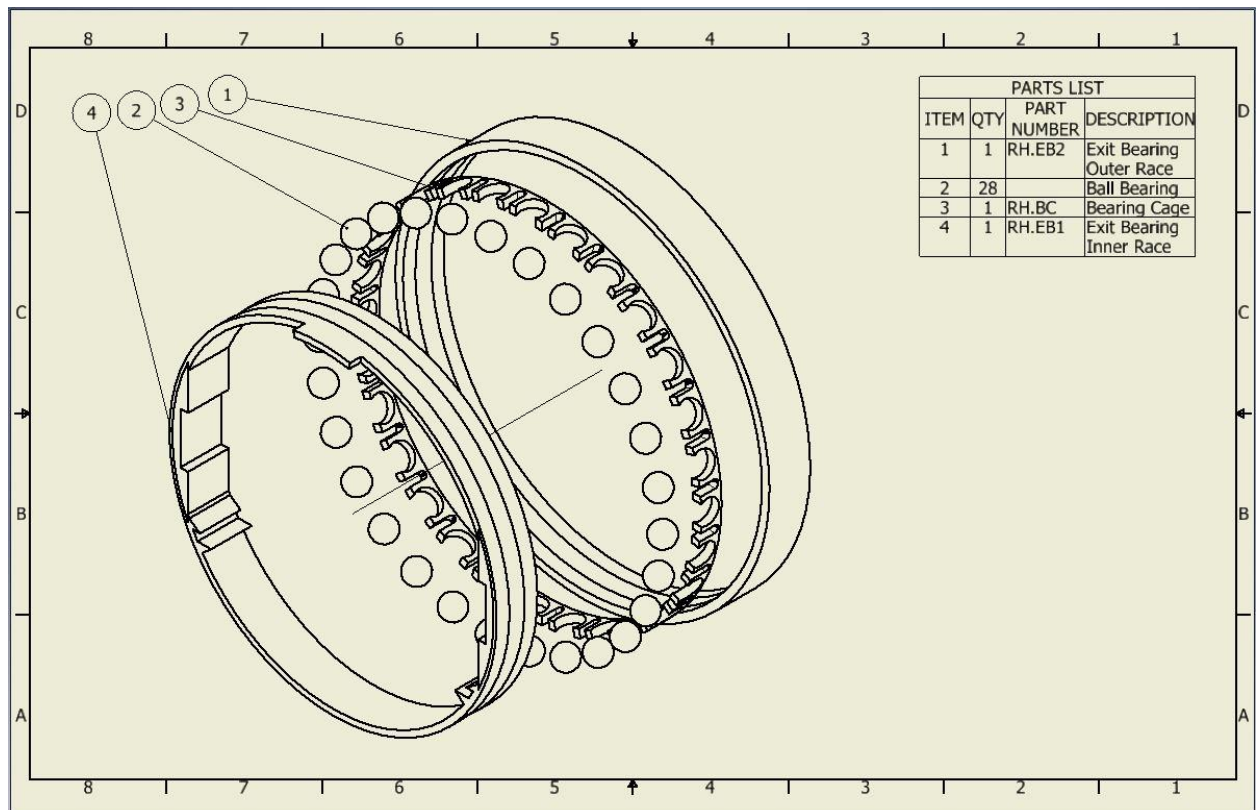

Figure 5-17: Exit Bearing Assembly

The Bayonet Bearing also has four components: The Bayonet Inner Race (RH.BB1), the Bayonet Outer Race (RH.BB2), the Bearing Cage (RH.BC), and the bearing balls as shown in figure 5-18. Both RH.BB1 and RH.BB2 are longer than their Exit Bearing counterparts to allow for a few additional features. RH.BB1 has a back wall to provide support to the Rover Wheels, which will rest against it. Both RH.BB1 and RH.BB2 have slots cut in the top and bottom, which the Bayonet Locking Rods (B4) will slide into to prevent rotation of the Rover Housing during launch.

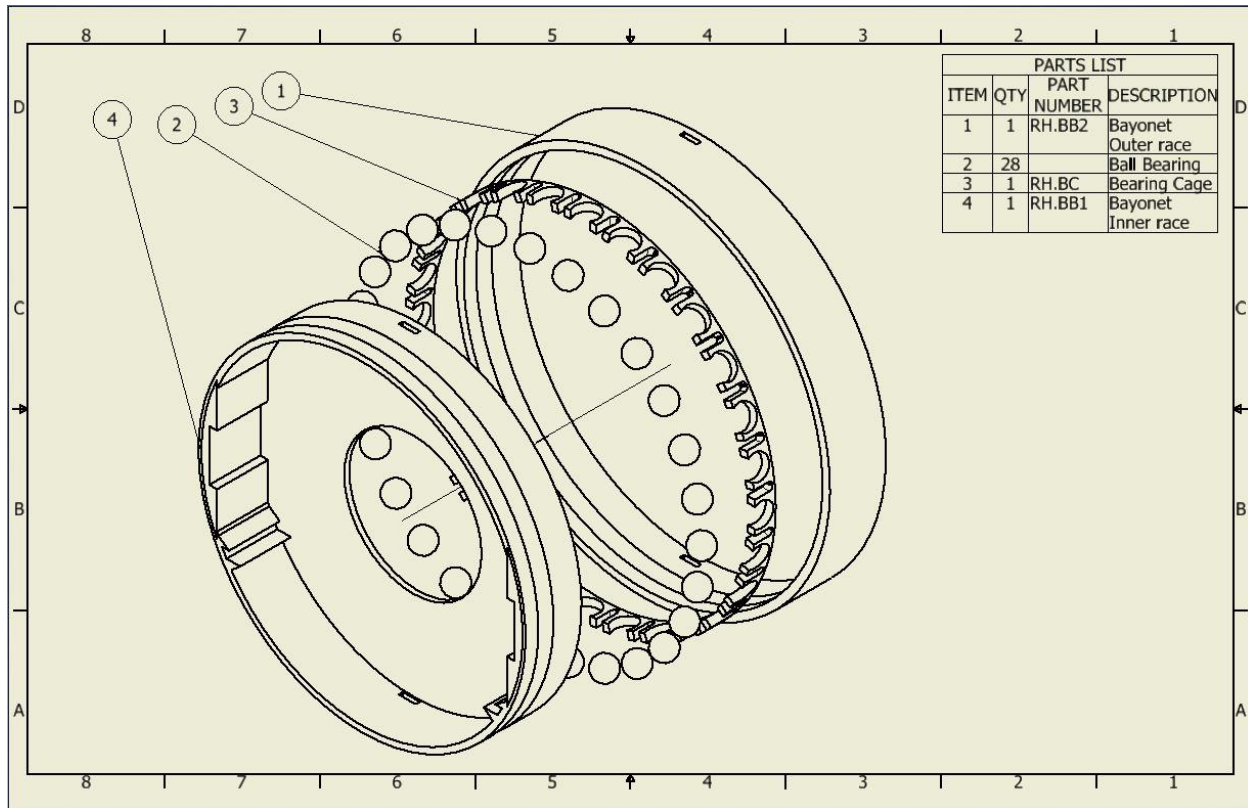

Figure 5-18: Bayonet Bearing Assembly

To prevent any motion during launch, several components of the Rover Housing were designed to restrict rotation and translation of the rover, inner races, and ramps. The rover is constrained to the rotation of the inner races by the Housing Rails (RH4). It is also prevented from vertical motion with respect to the rover by the Housing Rails and the Rover Platform (RH2). The Exit Ramp (RH1) is prevented from rotating toward the nosecone by the blast plate (not pictured above). The inner races of both bearings are constrained to the orientation of the outer races by the Locking Rod (B4) of the bayonet assembly, which is inserted into the slots in the Bayonet Inner Race (RH.BB1) and the Bayonet Outer Race (RH.BB2).

The Rover Platform (RH2) also has a mass below the surface the rover drives across, as shown in figure 5-19. A stainless steel rod is secured in a shell of the plastic of the Rover Platform. This rod acts as the weight that moves the center of mass of the Rover-Housing system far enough down to ensure that the Rover Housing will right itself after the rocket has landed.

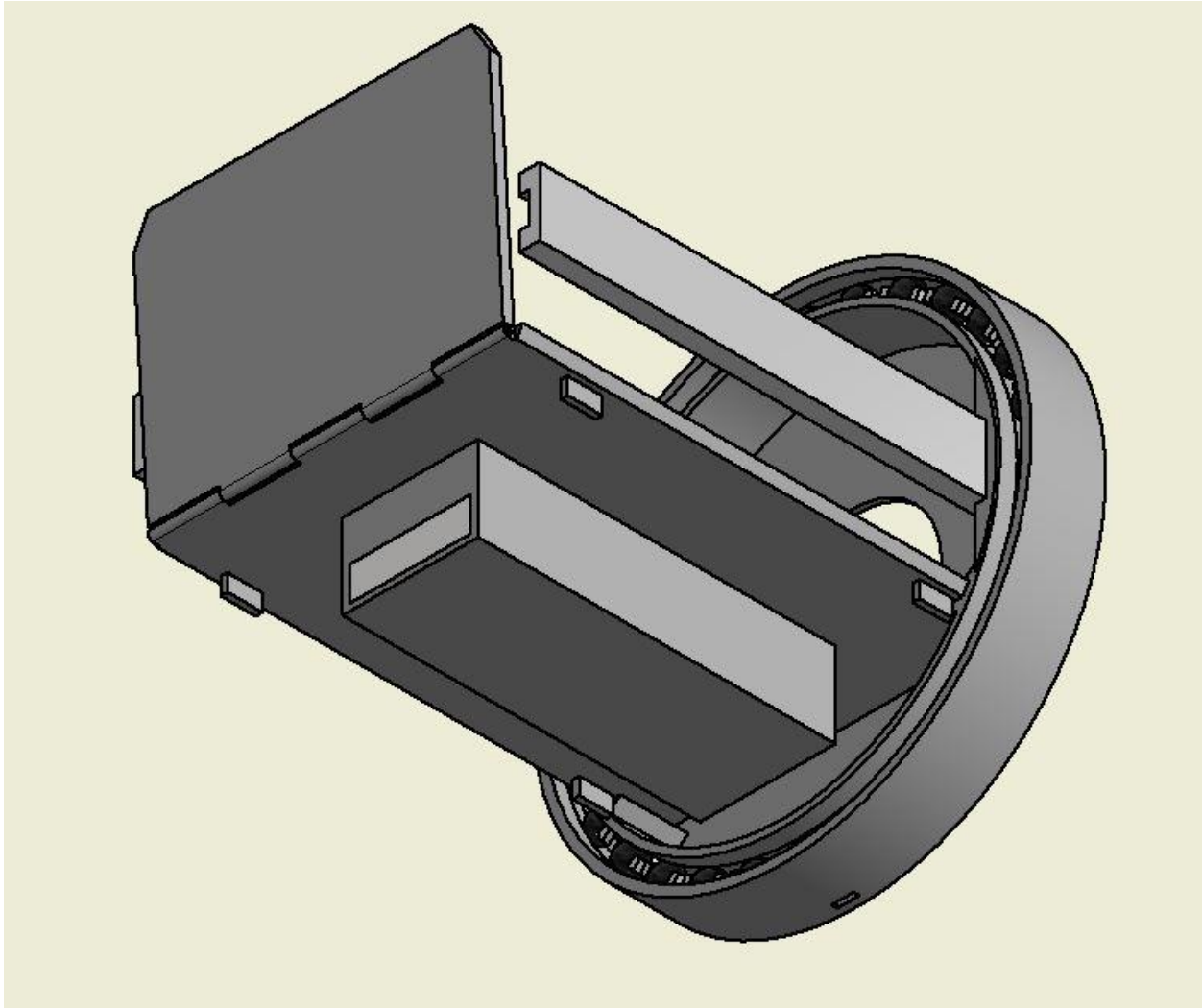

Figure 5-19: Platform and Counterweight (The Exit Bearing is suppressed in this image)

Behind the Rover Housing Assembly is the Rear Payload Assembly.

The function of this assembly is to provide the electric components required to release the Rover from the Rover Housing and allow the inner races of the bearings to rotate, as well as provide the counterweight required to bring the center of mass of the whole payload subsystem back to the center of the rocket. The 9V battery, Arduino Mini, Radio Receiver, and voltage regulator are all secured to the Back Panel (BP) with adhesive. The Bayonet Servo is inserted into a small slot in the Back Panel, since it experiences a torque when releasing the bayonet. It will also be secured into the slot with adhesive. The Back Panel will be secured to the airframe coupling with adhesive, just as the Exit Bearing and Bayonet Bearing are.

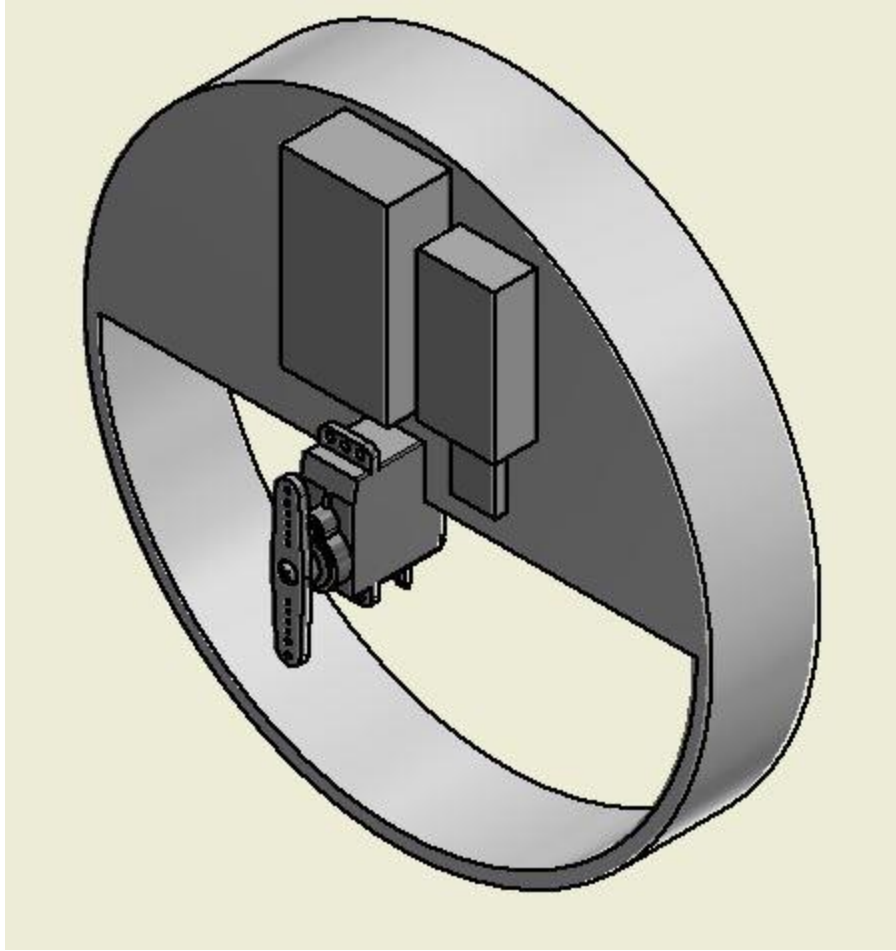

Figure 5-20: Rear Payload Assembly

As it can be seen in figure 454, the unique shape of the Back Plate adds enough mass across from the Rover Platform counterweight to bring the center of mass of the entire payload system back to the central axis of the rocket.

5.3 Electronics

5.3.1 Rover Battery

While choosing a battery the team had to focus on size, power and weight. The team chose to use the Turnigy Nano-Tech receiver pack to power the rover. The pack only weighs 0.22 pounds (98g) which is well below the amount allotted to the battery in the PDR. The battery has a voltage of 7.4V and a capacity of 2000 mAh. The control board can receive voltages from 3 to 5 volts, so a voltage regulator is required for the rover battery. The 20C Constant discharge can power the motors. The dimensions 3.43in x 1.34in x 0.67in (87mm x 34mm x 17mm), fit inside the rover

without taking up too much space. This pack is designed for model aircrafts, so it will be able to survive the changes in altitude and temperature that come with the rocket launch. The battery pack will be connected to all of the motors.

5.3.2 Payload Sensors

Any rover is designed to do more than just move away from the launch vehicle and open solar panels, and the R.I.C.K experiment is no different. After research in to the instruments included on the Curiosity Rover, the payload team decided to include several sensors to measure air temperature, barometric pressure, altitude, and atmospheric humidity.

5.3.3 Pressure/Altitude/Temperature Sensor

Due to the limited space aboard the rover, it is imperative to use sensor boards with multiple functions. The team has had to take the limited power and outpoint pins of the rover's control board into account when selecting sensors. The team settled on the MPL3115A2 Sensor Board because of its low cost and small size (18mm x 19mm x 2mm / .7" x .8" x .1"). The MPL3115A2 Sensor Board has pressure, altitude, and temperature sensors all contained on a single board. Due to its ultra-low power usage and high precision measurements (± 2 °C/ ± 1.5 Pa/ $\pm .3$ m), the MPL3115A2 fits the payload team's requirements. The MPL3115A2 is commonly used as an altimeter for model rockets so it can withstand with stress of flight and landing undamaged. The payload team chose this board as the best fit for the R.I.C.K. The MPL3115A2 will be placed on the rear of the rover underneath the control board. The MPL3115A2 Sensor Board is shown in Figure 5-21

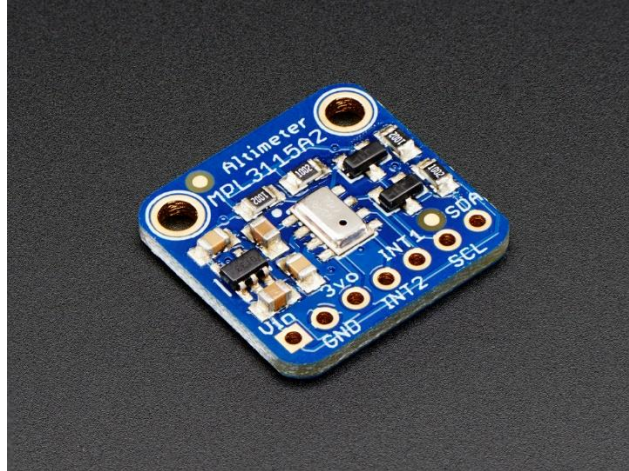

Figure 5-21: the MPL3115A2 Sensor Board

5.3.4 Humidity and Temperature

The Rover Environmental Monitoring Station (REMS) on the Curiosity Rover contains a humidity sensor, so the team wanted to gauge the relative humidity in the atmosphere from the R.I.C.K. We were unable to find a sensor board that contained a humidity sensor and another sensor that was not a part of any other board on the rover. Because of this the humidity board will also contain a redundant temperature sensor. Adafruit Si7021 Breakout Board will be used on the rover. The Si7021 has accurate reading for both temperature and humidity, with .4 C and 3% accuracies respectively. This board met the 5V capacity of the control board. The space saving capabilities of the SI7021 make it the prime choice for the payload team. The Adafruit Si7021 board will be housed on the rover next to the battery. Figure 5-22 shows the Adafruit Si7021 Breakout Board.

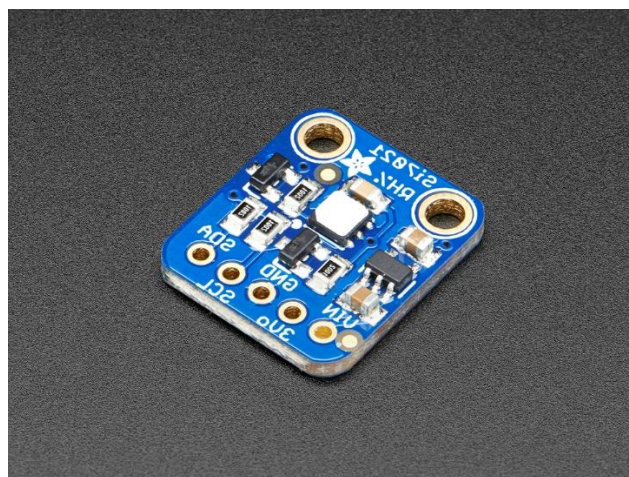

Figure 5-22: Adafruit Si7021 Breakout Board

5.3.5 Motors

An ESC will connect from the Arduino to the driving motor for each of the four wheels. These motors will be brushless DC motors with a kV of 2400 RPM*V.

5.3.6 Ultrasonic Sensor

At the front of the rover, an HC-SR04 Ultrasonic Sensor will be attached to the chassis. This sensor sends a 40 kHz bursts and listens for an echo. If there is an echo, meaning there is an object in front of the sensor, a signal is output to the Arduino. This will allow the Arduino to determine if there is an object in front of the rover and change its path accordingly.

5.3.7 Wiring Diagram

Figure 5-23 shows an approximate wiring diagram, including all motors, servos, and sensors that will be connected to the Aurdino and battery.

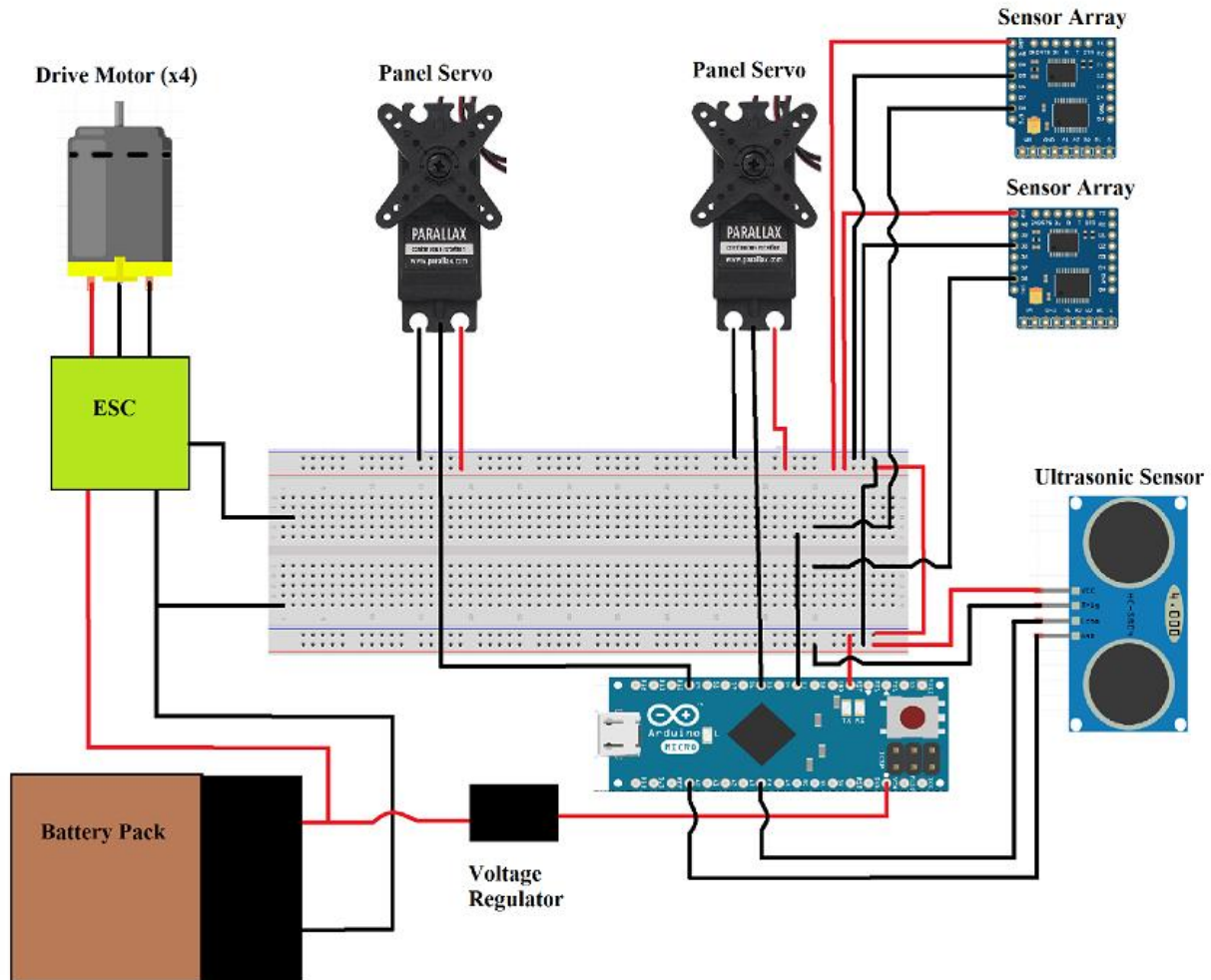

Figure 5-23 Wiring Diagram of the rover electrical system

5.3.8 Arduino Micro and Operating System

The rover will be controlled with an Arduino Micro model (16 MHz, 5V). The Arduino module will be activated upon receiving a signal (433 MHz) from ground operators. The decision to use an Arduino over a Raspberry Pi was primarily due to the lower size and weight of the Arduino, given the limited space. Figure 5-24 shows the logic flow chart for the deployment of the rover.

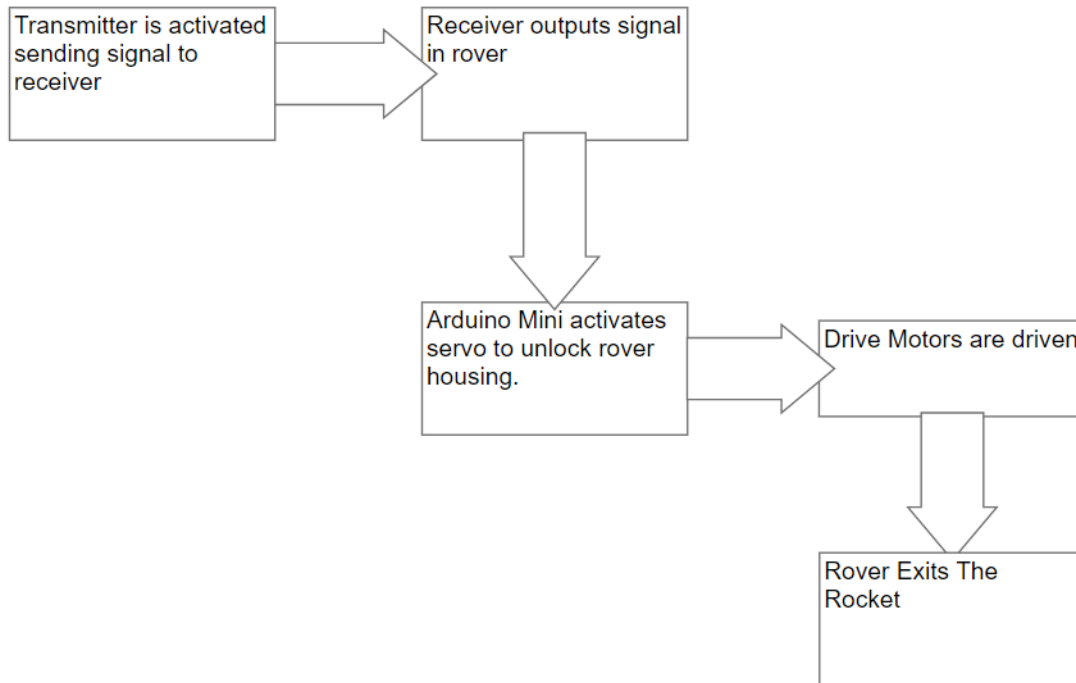

Figure 5-24 Rover Deployment Flow Chart

5.4 Justifications

5.4.1 Material

The payload components will largely be 3D-printed out of ABS plastic. Using this material and this manufacturing method allows for the unique geometry of all of the different components such as the inner races of both bearings, while reducing the number of surfaces that need to be joined together. Exceptions to this are the Hinge Pin (RH3), bearing balls, wheel axles, the bayonet pins, and the counterweight. The Hinge Pin will be made of Delrin, turned on a lathe because it is too small to 3D print. The bearing balls will be pre-purchased Delrin bearing balls, because 3D printed bearing balls tend to cause high bearing friction. The wheel axles will be made of carbon steel because they partially support the rover during flight. Every part of the chassis will be 3D printed out of ABS plastic as well, along with the solar panel plates and the bayonet fitting. The decision to use primarily ABS plastic was made because of the numerous beneficial properties the material possesses. It is significantly lighter than PLA, the other main plastic for 3D printing, and still has the necessary strength required to avoid yielding.

The counterweight was chosen to be made out of steel because it was necessary to have a very dense object that would occupy a small space and the small length of steel was enough to move the center of mass below the desired threshold.

5.4.2 Counterweight Placement

The counterweight under the Rover Platform (RH2) will be made of stainless steel. Before adding the counterweight (RH.CW), the center of mass of the rotating part of the payload system was 0.29 inches above the axis of the rocket, with respect to the rover. The center of mass needs to be sufficiently below the axis that the Rover Housing will rotate with gravity to correctly orient the rover after landing. The space under the Rover Platform is very limited, and is the only place that is appropriate for a counterweight. As a result, stainless steel was chosen due to its high density. To minimize the amount of steel we would need to use, the Rover Platform was adjusted to provide a slot for the stainless steel as far from the axis of the rocket as possible. After adding the counterweight, the center of mass of the rotating part of the payload system is .28 inches below the axis of the rocket, with respect to the rover. The payload team expects that this will be enough to drive the rotation of the Rover Housing. The tests performed on the Rover Housing will verify this.

To move the center of mass of the entire payload system back to the axis of the rocket, the Back Plate (BP) of the Rear Payload Assembly was designed with a unique shape (See Figure 5-20). The support structure for the electronic components is a semicircle, where the mass is oriented exactly opposite of the Rover Platform counterweight (RH.CW) in relation to the axis of the rocket. Since the space here is only limited by the rocket interior, the Back Plate is 3D printed out of ABS plastic, and no additional materials are required. Allowing for inexact values of vendor masses for electronic components, the center of mass of the entire payload system is less than .005 inches from the central axis of the rocket.

6. Project Plan

6.1 Testing

6.1.1 Vehicle

6.1.1.1 DACS System

We will be doing wind tunnel testing on our sub and full scale Dynamic Apogee Control System (DACS) at the National Wind Institute at Reese Air Park. We will be gathering data on drag forces varying with wind speed using the load cells that the facility has. We will test how different angles of DACS flap deployment will affect the amount of drag on the launch vehicle. We will then use this data to determine how DACS deployment angle effects the launch vehicles drag coefficient. This will allow us to accurately regulate our desired apogee.

6.1.1.2 Aerodynamic Drag Testing

We complete aerodynamic drag testing on both sub and full scale using the wind tunnel at the National Wind Institute located in Reese Airpark. Using load cells, we will conduct tests on the drag forces created by our launch vehicles to then extrapolate drag coefficients.

6.1.1.3 DACS Control Arms

The control arms used to extend the flaps as a part of the Dynamic Apogee Control System will have to withstand large compressive forces. To be able to handle the large stresses that these four control arms will undergo, we have decided to make them out stainless steel. In order to ensure they can handle such stresses we will perform an ultimate failure analysis in the Texas Tech Mechanical Engineering Department's machine shop. The results from this test will show us the maximum strength of these control arms.

6.1.2 Recovery

6.1.2.1 Sub-scale Separation Charge testing

Before sub-scale testing, we did two separate tests to ensure that our separation charges were adequate to separate the sections of the launch vehicle. We tested the main parachute ejection

charge as well as the drogue parachute ejection charge. In this case both main and drogue chute charges successfully separated with 0.5 grams of 4F black powder.

6.1.2.2 Large Scale Separation Charge Testing

The separation charges that we have calculated for the large-scale rocket (Raider 2) will be tested before the large-scale test launch. We will do this in a similar fashion to the small-scale. Both drogue and main chute separation charges will be tested until success as well as several tests upon the nose cone separation that will allow for rover deployment.

6.1.2.3 Shock Cord Bundle Testing

Part of our procedure for packing the shock cord is to fold it every 4 inches until a one-foot bundle is achieved. Each bundle will then be taped in the center with one layer of electrical tape. We will do this continually throughout the length of the shock cord. This will allow for greater energy absorption. While the shock cord is unraveling. We will test this principle by dropping a weight connected to this bundle while connected to a fish scale to record the force experienced during the drop. This could shed some light onto how much force it takes to pop the tape on each bundle and whether or not it provides adequate shock absorption.

6.1.3 Payload

6.1.3.1 Rover Housing

The test and analysis for the bearing housing system will be conducted with full size models and computer simulations. The bearing system full-size models will be stress tested with mock rovers with similar weights. All possible landing orientations will be tested with mock rovers to ensure functionality. These tests must be conducted prior to any test launches aboard the vehicle.

6.1.3.2 Payload Interface

The payload interface system includes the bayonet fitting and the axles and tracks. The axles and tracks will be tested with full sized models of both the rover and payload housing. Stress simulations will be run on the bayonet fitting prior to creating full scale models. All the tests for scale models will be run in cognition with the testing of the payload housing.

6.1.3.3 Electrical Systems

The electrical systems include all electrical components outside of pre-fabricated sensors and motors. The heart of the Electrical system and the rover itself, the control board will be inspected for any faults before installation and after any test of the rover. All sensors will undergo calibration testing in controlled environments to ensure accuracy. Voltage and amperage will be measured across the system to ensure all levels are within a safe range specified in our safety sheets.

6.1.3.4 Drivetrain and Steering

Drivetrain and steering systems are defined as systems responsible for the movement and the automated steering of the rover. All motors will be tested prior to installation to ensure all they are able to meet the required minimum forces. The steering system will undergo testing in controlled environments to ensure all sensors are accurate and the system will respond to obstacles as planned. The team will conduct a full-scale test in corn or cotton fields to simulate the expected performance environment.

6.1.3.5 Solar Panel Deployment

Solar panel deployment system consists of the panel housing, the deployment gear assembly, and the deployment motor. The entire system will undergo computer simulated stress testing prior before any scale models are constructed. The motor output will be tested and measured to ensure it meets projected forces.

6.2 Requirements Compliance

6.2.1 Vehicle Requirements

Vehicle Requirements	Design Features to fulfill the requirements
<i>The vehicle will deliver the payload to an apogee altitude of 5,280 feet above ground level (AGL)</i>	Make sure the simulation is around 1609 meters and stays below 1700 meters (5577.428 feet).
<i>The vehicle will carry one commercially available, barometric altimeter for recording the official altitude used in determining the altitude award winner. Teams will receive the maximum number of altitude points (5,280) if the official scoring altimeter reads a value of exactly 5280 feet AGL. The team will lose one point for every foot above or below the required altitude.</i>	We will have two Stratologger CF altimeters for main and backup altimeters. The backup altimeter will be the designated altimeter for NASA.
<i>Each altimeter will be armed by a dedicated arming switch that is accessible from the exterior of the rocket airframe when the rocket is in the launch configuration on the launch pad.</i>	We will have the switches built into the body frame which can be accessed from the outside body. Each altimeter will have its own designated switch.
<i>Each altimeter will have a dedicated power supply</i>	We will have two 9-volt batteries which are connected to each altimeter
<i>Each arming switch will be capable of being locked in the ON position for launch (i.e. cannot be disarmed due to flight forces)</i>	We will have the switch built in into the body near the e-bay.
<i>The launch vehicle will be designed to be recoverable and reusable. Reusable is defined as being able to launch again on the same day without repairs or modifications.</i>	We will design the rocket to be recoverable and reusable by putting focus on the recovery system to land the rocket in a recoverable state and not to damage the rover.

<p><i>The launch vehicle will have a maximum of four (4) independent sections. An independent section is defined as a section that is either tethered to the main vehicle or is recovered separately from the main vehicle using its own parachute.</i></p>	<p>The design of our rocket is in 3 independent sections being the nose cone with the first upper section of body where the payload is located, the section that contain the E-bay, and lower part of body where the motor is. The first separation will happen when the launch vehicle hits apogee and the drogue chute will be deployed. The second separation will happen at 700 AGL ft where the main parachute will deploy.</p>
<p><i>The launch vehicle will be limited to a single stage.</i></p>	<p>The rocket is a single staged rocket.</p>
<p><i>The launch vehicle will be capable of being prepared for flight at the launch site within 3 hours of the time the Federal Aviation Administration flight waiver opens</i></p>	<p>We will have the rocket prepared and ready for flight no later than the day before launch so that no problems arise before the 3 hours the FAA flight waiver opens.</p>
<p><i>The launch vehicle will be capable of remaining in launch-ready configuration at the pad for a minimum of 1 hour without losing the functionality of any critical on-board components.</i></p>	<p>We will design the electronics of the rocket and rover to be ready for at least an hours' time of launch.</p>
<p><i>The launch vehicle will be capable of being launched by a standard 12-volt direct current firing system. The firing system will be provided by the NASA-designated Range Services Provider.</i></p>	<p>The launch vehicle will have 1515 rail buttons to slide onto the launch rail to guide the launch vehicle.</p>
<p><i>The launch vehicle will require no external circuitry or special ground support equipment to initiate launch (other than what is provided by Range Services).</i></p>	<p>The launch vehicle will only have the electronics for altimeter and rover which are already included inside the vehicle.</p>

<p><i>The launch vehicle will use a commercially available solid motor propulsion system using ammonium perchlorate composite propellant (APCP) which is approved and certified by the National Association of Rocketry (NAR), Tripoli Rocketry Association (TRA), and/or the Canadian Association of Rocketry (CAR).</i></p>	<p>The motor for the full-scale will be a Cesaroni L1395-BS.</p>
<p><i>Pressure vessels on the vehicle will be approved by the RSO and will meet the criteria of 2.14.1, 2.14.2, and 2.14.3 in the handbook</i></p>	<p>We will perform pressure tests on the rocket to make sure it is passing.</p>
<p><i>The total impulse provided by a College and/or University launch vehicle will not exceed 5,120 Newton-seconds (L-class).</i></p>	<p>The total impulse of our motor for the full-scale is 4895.4 Newton-seconds.</p>
<p><i>The launch vehicle will have a minimum static stability margin of 2.0 at the point of rail exit. Rail exit is defined at the point where the forward rail button loses contact with the rail.</i></p>	<p>The launch vehicle will have a simulation stability margin of at least 2.0.</p>
<p><i>Take-off fails</i></p>	<p>Ensuring Rail buttons can slide freely along the rail, and the motor igniter is placed all the way in the top of the fuel grain.</p>
<p><i>The launch vehicle will accelerate to a minimum velocity of 52 fps at rail exit.</i></p>	<p>We will calculate the rail exit velocity to confirm the minimum velocity of 52 fps will be achieved</p>
<p><i>All teams will successfully launch and recover a subscale model of their rocket prior to CDR. Subscals are not required to be high power rockets. 2.18.1-2.18.2</i></p>	<p>We have successfully launched a subscale model of the rocket.</p>

<p><i>All teams will successfully launch and recover their full-scale rocket prior to FRR in its final flight configuration. The rocket flown at FRR must be the same rocket to be flown on launch day. The purpose of the full-scale demonstration flight is to demonstrate the launch vehicle's stability, structural integrity, recovery systems, and the team's ability to prepare the launch vehicle for flight. A successful flight is defined as a launch in which all hardware is functioning properly (i.e. drogue chute at apogee, main chute at a lower altitude, functioning tracking devices, etc.). 2.19.1 – 2.19.7</i></p>	<p>The launch vehicle we fly during the FRR will be the same launch vehicle used on launch day. We will however use a weight in place of our rover during FRR.</p>
<p><i>Any structural protuberance on the rocket will be located aft of the burnout center of gravity.</i></p>	<p>It will be located at the burnout center of gravity.</p>
<p><i>Vehicle Prohibitions</i></p>	<p>Our motor will <u>not</u> be a hybrid, a cluster, utilize forward canard and firing motors, utilize friction fitting, and will not exceed Mach 1 at any point during the flight. In addition, the vehicle ballast will not exceed 10% of total weight of our rocket.</p>

6.2.2 Recovery Requirements

Situation	Level of Risk	Prevention of Risk
<p>Altimeter fails</p>	<p>Low</p>	<p>Have multiple altimeters and have redundancy so that in case one fails, the recovery system still deploys.</p>

Drogue not deploying	Medium	Listen to the altimeters for the continuity beeps that will ensure charges for drogue, and main parachutes are armed
Main chute not deploying	High	Listen to the altimeters for the continuity beeps that will ensure charges for drogue, and main parachutes are armed
Parachute entanglement	Medium	The parachutes will be packed correctly, and dual deployment orientation will be tested during sub-scale launch
Nose cone not ejecting after landing	Low	Ground testing to make sure that the body can separate.

6.2.3 Payload Requirements

Payload Requirements	Design Features to fulfill the requirements
Custom rover that will deploy from the internal structure of the launch vehicle	The payload team will 3D print a rover which will be constrained inside a housing inside the rocket and will autonomously drive out after landing.

Remote activation of the rover	<p>There will be a receiver on the rover which will initiate the rover's programming when it obtains a signal from our transmitter.</p> <p>The exit ramp will be resting on the bulkhead so that it will fall when the bulkhead ejects, allowing the rover to exit the rocket without detecting an obstacle. To ensure that the exit ramp will fall, there are a set of pegs that will protrude from the exit bearing in order to keep the exit ramp at an appropriate angle where its center of gravity will force it to fall down as desired.</p>
Rover must autonomously travel at least 5ft in any direction after exiting the rocket	<p>The rover will be equipped with an Arduino Micro microcontroller which will control all of the motors and other electronics, allowing the rover to be completely autonomous once it receives the initial signal from the transmitter.</p> <p>The rover is also equipped with an ultrasonic sensor, allowing the rover to avoid obstacles that could potentially prevent the accomplishment of this task.</p>
The rover must deploy solar panels once it reaches its final destination	<p>The rover will be equipped with a set of two servos and four hinges that will unfold two plates which will allow five solar panels to access direct sunlight.</p>

<p>The payload housing must rotate after landing to allow the rover to depart the rocket in an upright position</p>	<p>To ensure that the two ball bearings will rotate after landing, no matter what orientation the rocket lands in, a small counter weight was added to the rover housing. This counterweight effectively shifts the center of mass of the rover below the centerline of the rover, so that when the center of mass is pulled down by gravity, the rover will be in an upright position.</p>
---	---

6.2.4 Safety Requirements

Requirement	Verification
<p>Authorized Personnel during construction and operating any machinery.</p>	<p>Any General RAS involvement at our construction facility, Reese Research Park, must have a RAS Officer present at all times in ensure proper behavior and utilization of equipment. However, during Space Raiders construction, the Safety Officer must be in attendance as well.</p>
<p>G10 Fiberglass Sanding and Hazard Concerns</p>	<p>G10 can be dangerous when inhaled. For this reason, wet sanding will take place to prevent particles from escaping into the air in addition to breathing masks.</p>
<p>Epoxy handling and application</p>	<p>Handling and application of epoxy will only take place with the utilization of safety gloves and disposable towels. In the event it must be removed from skin, the sink nearby will be available.</p>
<p>Rocket Motor Storage and Handling</p>	<p>Rocket motors will be stored and locked away in a flammable cabinet. Only a Space Raider officer is authorized to handle any rocket motors.</p>

E-Match	E-Matches will be stored away from heat and humidity. It will only be installed into a rocket by the Safety officer if it is not overheated.
Safety Exams	Members are not authorized to be present at Reese Research Park unless the required safety exams have been passed. These records are documented by the safety officer.
Black Powder Storage and Handling	Black Powder is to only be handled by Space Raider Officers and measured to the tenth of a gram when loading. Black powder will be stored and locked away in a flammable cabinet.
Personal Protective Equipment (PPE)	PPE is provided at the entrance of the Reese warehouse facility. Members in attendance will be wearing safety glasses at all times. Additional safety equipment is easily accessible at all times and strongly enforced.
Facility Safety Awareness Signs	Safety signs are posted on the walls at least every 10 feet. These serve as a reminder for safety relative to the area of warehouse and our general policies about wearing safety glasses at all times.
Behavior and Conduct	Horseplay or aggressive actions towards any and all persons at the facility will not be tolerated. The consumption, possession, and the presence of alcohol will not be tolerated on the facility property. All food and drinks must be kept out of construction zones.

Clothing Standards	<p>Always use personal protective equipment while operating equipment. Complete coverage of feet must be worn. Hair should be secured with proper hair accessories. Jewelry must be removed before using any equipment. No baggy clothing will be worn while using equipment. Pants must be worn while using equipment. Shirts should be tucked in and long sleeves tightly rolled up. Do not wear gloves while operating equipment unless handling rough materials. Wear ear protection while around working around loud equipment. Use proper ventilation and wear masks to avoid breathing in harmful material debris.</p>
Fire awareness	<p>A fire extinguisher will be stored in the same room as the flammable cabinet and in general construction zone at all times.</p>
Launcher Set Up	<p>Only the Safety Officer and other Space Raider Officers are permitted on the launch pad. The launch pad will be notified when lowering or raising the launch rail. The launch pad will be notified before executing any action consisting of: Connecting ejection charges, turning altimeters on, loading shear pins, sealing any section with screws, loading rocket motor, loading motor igniter, connecting motor igniter to electrical leads, activating rover, and running through all electrical light and beeping signals.</p>
Emergency Safety Equipment	<p>Emergency safety equipment will be visible, accessible, and introduced to every member who enters the warehouse area. Emergency Safety Equipment will be on the safety officer when off-site from Reese warehouse in a testing or launching environment.</p>

6.3 Budget

Raider Aerospace Society (RAS) within Texas Tech University will acquire all funding. Space Raiders, functioning as a subsidiary of Raider Aerospace Society will be funded by the parent company (RAS). The society’s treasurer, Russell Curlee, will continue seeking funding and budgeting for RAS. Space Raiders funding will be spearheaded by Hector Ruiz. A line item budget with parts and prices are detailed below. All prices are subject to an 8.25% sales tax unless otherwise noted. Furthermore, income will be separated into three categories: Funding, Material acquisition, and Facilities/services.

Expenses		Income	
Recovery Parts	\$740.00	RAS	\$2,250.00
Vehicle Parts	\$1,320.00	Top Tier	\$1,200.00
DACS Parts	\$130.00	Sponsor 1	\$750.00
Payload Parts	\$310.00	ME Dept.	\$1,000.00
Travel	\$2,650.00	Eng. College	\$1,200.00
Freight	\$350.00	Sponsor 2	\$500.00
Sponsor investment	\$1,001.00	Sponsor 3	\$250.00
Miscellaneous	\$500.00	Sponsor 4	\$250.00
Safety	\$269.00	Sponsor 5	\$250.00
Scale Model	\$550	Sponsor 6	\$500.00
	\$7,820.00		\$8,150.00
All values rounded to highest dollar			
10% + accounted for spare parts			
Taxes and Shipping accounted for			

Fig. 6-1

*See figure 6-3, 6-4, 6-5, and 6-6 for Recovery, Vehicle, DACS, and Payload parts respectively

6.3.1 Funding

Top Tier- Texas Tech University uses Top Tier catering services. Each member will participate in a 10-hour shift which will incur \$100 per shift to the organization.

The Whitacre College on Engineering has agreed to aid in the fundraising process. The Development Director will personally oversee the progress as well as aiding with a contribution.

The Texas Tech Mechanical Engineering department has had a history of matching funds, dollar-dollar, an organization can fundraise on its own. The organization must demonstrate the funds are to be used for goals aligning with the department's mission, ethics, and standards.

Rush Enterprises has demonstrated interest in sponsoring the project in an effort to support the caliber of engineering students graduating from the university.

Raider Aerospace Society has allocated \$2000 towards Space Raider's mission in NASA's university student launch initiative.

Local businesses popular with the university will be offered a presence in the organization's literature as well as potential company logos on the rocket's body which will appear in local news channels. Further negotiations with local businesses will seek a mutually beneficial relationship. All businesses who contribute to the organization's mission will also receive tax exemption credits. See figure 6.2.

A Gofundme account has been created to further acquire funds as the organization grows and gains supporters. The organization received approval to function as a non-profit from the Internal Revenue Service. With the EIN of a non-profit the organization can now guarantee tax break vouchers for sponsor companies. This is detailed in the contract created for sponsorship agreements between the sponsor and the organization.

6.3.2 Recovery Parts List

##	Name	Quantity	Price	Total Price	Store
1	16 ft 1.1 Ripstope Nylon	1	\$170.00	\$170.00	http://www.the-rocketmar
2	2 ft 1.9 Ripstop Nylon	1	\$33.00	\$33.00	http://www.the-rocketmar
3	15 ft Kevlar Covered Tubular Nylon Webbing	1	\$40.00	\$40.00	http://www.the-rocketmar
4	40 ft Kevlar Covered Tubular Nylon Webbing	1	\$65.00	\$65.00	http://www.the-rocketmar
5	9in NOMEX Blankets	1	\$7.00	\$7.00	http://cart.amwprox.com/i
6	30in NOMEX Blankets	1	\$18.00	\$18.00	http://cart.amwprox.com/i
7	3/8in Eyebolt	14	\$0.85	\$11.90	Hardware Store
8	^^ Nuts	14	\$0.85	\$11.90	Hardware Store
9	Paracord 100ft	1	\$8.29	\$8.29	https://paracord.com/colle
10	T3 GPS Tracking System	1	\$149.45	\$149.45	https://www.missileworks
11	9 volt Bttery 4 pack	1	\$14.95	\$14.95	Hardware Store
12	Perfect Flight StratologerCF	2	\$54.95	\$109.90	http://www.perfectflite.co
13	Switch	3	\$2.95	\$8.85	Hardware Store
14	Long Distance RF Switch Transmitters & Receivers	2	\$11.99	\$23.98	https://www.amazon.com/dp/B01G8B9PR8/ref=asc
15	E-Match	6	\$0.05	\$0.30	Mentor
16	Centerfuge Tube	20	\$0.01	\$0.20	Mentor
17	Black Powder	50	\$0.02	\$1.00	Mentor
				Total	\$673.72

Fig. 6-3

6.3.3 Vehicle Parts List

Part	Material	Size	Qty	Cost (ind)	Source	Total
Fins	G10	3ftx1ft 3/16in	1	53.000	http://www.eplastics.com	53.00
Motor Retainer ring	AL	75mm	1	53.000	https://www.apogeerockets.com	53.00
Body Tube	Blue Tube	6in diam 4 ft	2	66.000	https://www.apogeerockets.com	132.00
Nose Cone	ABS	6.25inx20in	1	0.000	Mechanical Engineering	0.00
Mounting Screws	Steel	1/8in	24	0.100	Hardware Store	2.40
Mounting Nuts	Steel	1/8in	24	0.100	Hardware Store	2.40
Thrust Plate	AL	6in	1	65.000	https://www.apogeerockets.com	65.00
Inner Tube	Fiberglass	75mm	1	0.000	Bill's surplus	0.00
Epoxy	G5000	2pints	1	0.000	Previous expense	0.00
Foam	2 Part mix	Pub Missles	1	0.000	Bill's surplus	0.00
Fuel Grain	AP	75m 4 grain	2	247.000	https://csrocketry.com	494.00
Motor Casing	Aluminum	75mm	1	331.000	https://www.apogeerockets.com	331.00
Rail Buttons	Delrin	1515	2	0.000	Surplus	0.00
Coupler	Blue Tube	4 feet	1	66.000	https://www.apogeerockets.com	66.00
					Total	\$1,199

Fig. 6-4

6.3.4 DACS Part List

Part	Cost	P/N	Source	Total
Pressure sensor	\$15	SparkFun Altitude/Pressure S	https://www.sparkfun.com/products/11084	
Accelerometer	\$10.49	SparkFun Triple Axis Accelerometer Breakout - MMA8452Q (with Headers)	https://www.sparkfun.com/products/13926	
Linear Actuator	\$75	PA-14P	https://www.progressiveautomations.com/linear-actuato	
Control Arms	\$0	Custom DMLS	ME shop	
G10 Flaps	\$0	G10 Fiberglass	Surplus	
G10 Ribs	\$0	G10 Fiberglass	Surplus	
Removable Bulkhead	\$0	Aluminum (milled)	ME shop	
Fixed Bulkhead	\$0	Plywood	Surplus	
Hinges	\$0	Aluminum (milled)	ME shop	
Crown	\$0	Aluminum (milled)	ME shop	
Battery	\$?	Lithium		
Pins	\$0	Stainless steel (milled)	ME shop	
Arduino UNO	\$0	Microcontroller	Surplus	
			Total	\$100.49

Fig. 6-5

6.3.5 Payload Parts List

Item	Descriptions	Price	Qty	Total Price	Part No	Link
General						
.125" Plastic Stock	12" x 12"	\$4.23	1	\$4.23	8619K441	https://www.mcmaster.com
.25" Plastic Stock	6" x 12"	\$4.62	1	\$4.62	8619K751	https://www.mcmaster.com
.5" Plastic Stock	12" x 12"	\$7.46	1	\$7.46	8619K461	https://www.mcmaster.com
1" Plastic Stock	6" x 6"	\$13.23	1	\$13.23	8619K614	https://www.mcmaster.com
3D Printing Materials	-	\$0.00	1	\$0.00		https://www.depts.ttu.edu
3D Printing Machine Time	-	\$0.00	1	\$0.00		https://www.depts.ttu.edu
Bearing Housing						
Motor for Bayonet	Servo	\$13.99	1	\$13.99	900-00008	https://www.alliedelec.com
Spring for Bayonet	.2 OD, .36" CL, .49 LB	\$0.61	1	\$0.61	965K46	https://www.mcmaster.com
Rover						
Raspberry Pi	3 Model B	\$34.90	1	\$34.90		https://www.amazon.com
Pressure/Altitude/Temp.	MPL3115A2 - I2C	\$9.95	1	\$9.95	MPL3115A2	https://www.adafruit.com
Temp & Humidity Sensor	Adafruit Si7021	\$6.95	1	\$6.95	Si7021	https://www.adafruit.com
ZIPPY Compact Battery		\$10.56	2	\$21.12	9067000018-	https://hobbyking.com/en
Step Down Regulator		\$3.95	1	\$3.95	2098	https://www.pololu.com/
Wires	80 pc set	\$5.99	1	\$5.99	4330587431	https://www.amazon.com
Breadboard	Solderable Breadboard	\$4.95	1	\$4.95	PRT-12070	https://www.sparkfun.com
Ultrasonic sensor		\$3.95	2	\$7.90	474-SEN-1395	https://www.mouser.com
Solar Panel	53X30mm	\$0.59	3	\$1.77		https://www.aliexpress.com
Panel Deployment Servo	1.3"x1.2"x0.5" servo	\$7.50	2	\$15.00	2442	https://www.adafruit.com
Torsion Springs	1 in-lb torque, 6 pk.	\$6.41	1	\$6.41	9271K31	https://www.mcmaster.com
Wheel Bracket Pins	1/16" x 3" Shaft	\$2.70	1	\$2.70	1327K83	https://www.mcmaster.com
Wheel Extension Motor	Brushed motor 256:1 r	\$4.96	2	\$9.92	225000049-0	https://hobbyking.com/en
Wheel Extension Screw	ASTM A193 Steel ACM	\$8.98	2	\$17.96	93420A881	https://www.mcmaster.com
Drive Motor	4 pk	\$13.99	4	\$55.96	RV2306	https://www.hobby-wing
ESC	BLHeli Series, 30Amp	\$13.00	2	\$26.00	XT60	https://store.flitetest.com
				Total	\$275.57	

Fig. 6-6

6.3.6 Safety Parts List

Equipment	Qty	Price	Total	Vendor Link
Eye Goggles	14	\$1.20	\$16.80	ds&id=294711
Safety Glasses	12	\$1.85	\$22.20	ds&id=40789
Disposable Gloves	200	\$0.06	\$12.00	https://www.t
Disposable Coveralls	25	\$1.24	\$31.00	id=CjwKCAjwh
Breathing Mask	20	\$0.60	\$12.00	ype=pla&id=S-
Wool/Nylon Fire Blanket	1	\$55.50	\$55.50	/UMO3AAAAG
Poly Plastic Tarp	4	\$2.80	\$11.20	iwAx2nhLovM
First Aid Kit	1	\$25.00	\$25.00	293&gclid=Cjw
ABC Class Fire Extinguisher	1	\$60.00	\$60.00	=S-9873&gclid
			\$245.70	

Fig. 6-7

6.4 Timeline

6.4.1 Vehicle

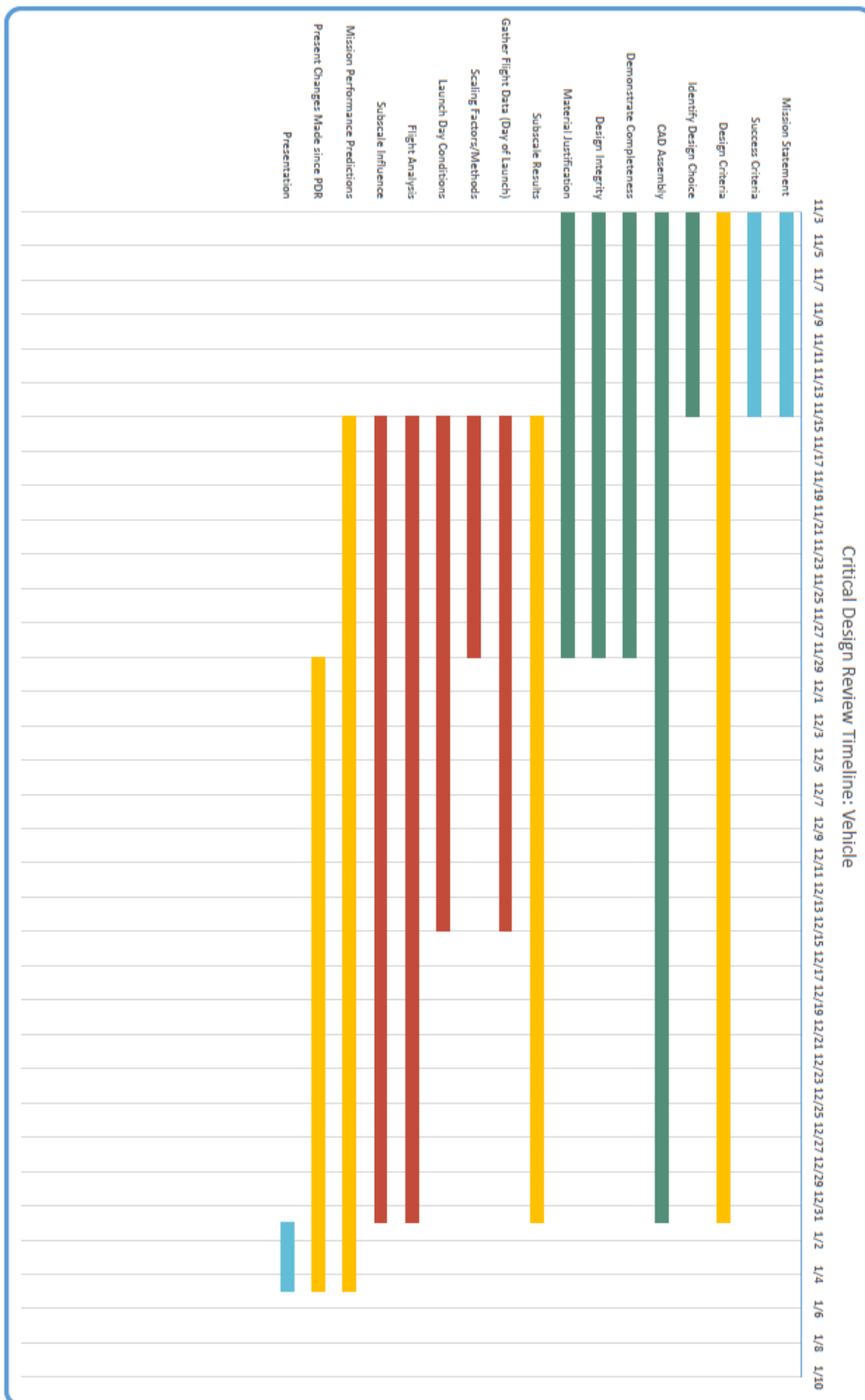

6.4.2 Recovery

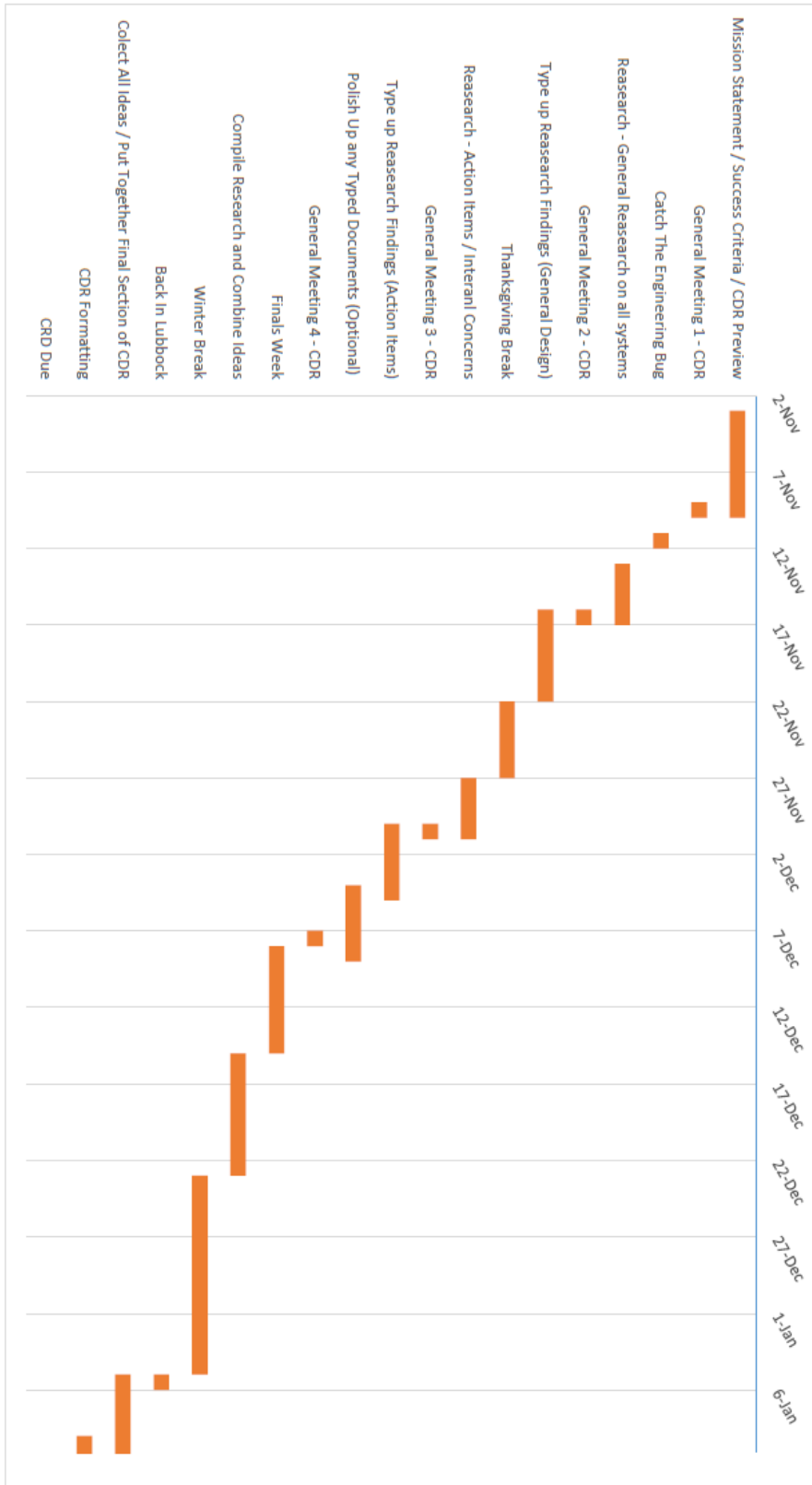

7. Dynamic Apogee Control System

The DACS is a second experimental payload that will be incorporated in this project. The interface of the DACS will be directly mounted to the airframe of the launch vehicle, directly above the motor. This system will serve the purpose of adjusting the flight path by influencing the total drag that is acting upon the Raider 2. It will be programmed with a predictive code that will be able to determine the angle of flap opening in order to reach a target apogee, granted the rocket will overshoot the target.

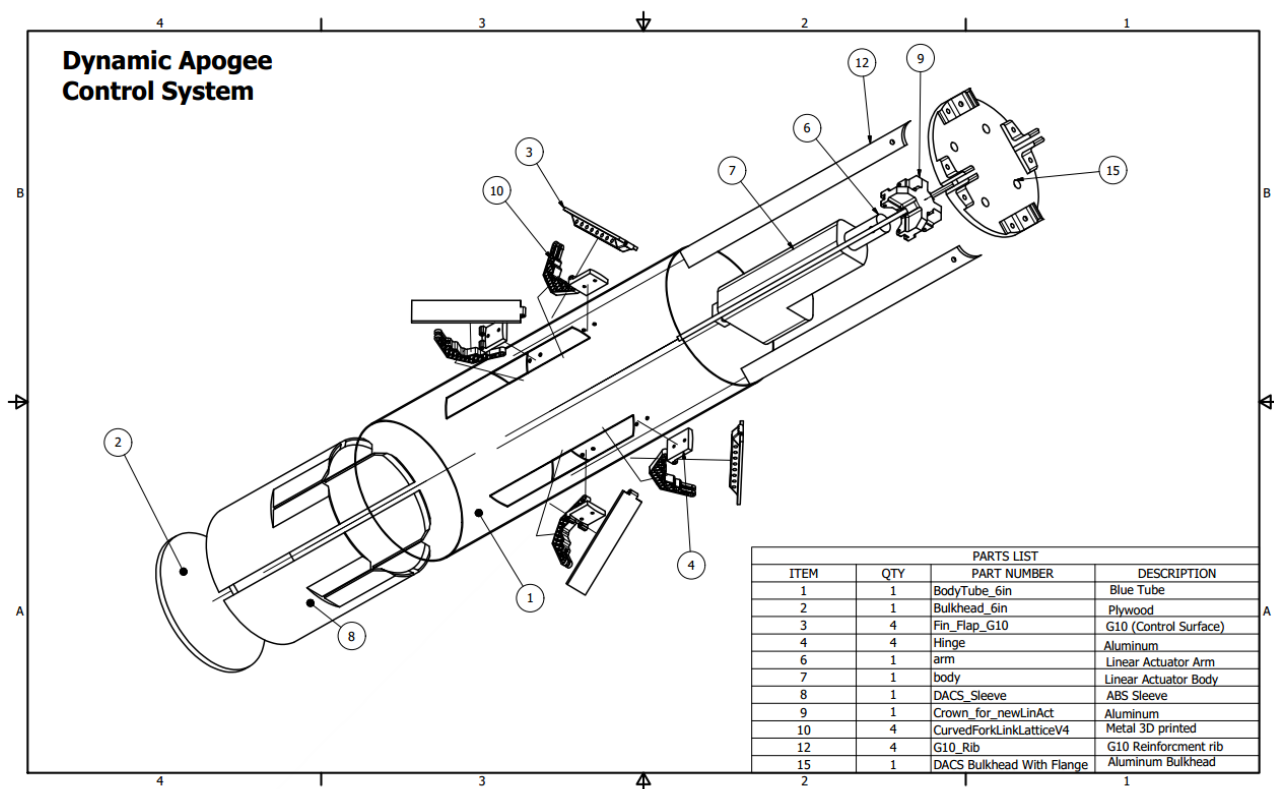

Fig 7-1

7.1 Parts

The DACS will be a complex system, requiring many custom machined parts and specialty hardware and electronics. Members of the group have shop experience and are becoming more familiar with precision machining instruments such as the Bridgeport and CNC end mill, as well as the Lathe in order to fabricate parts such as the control arms, central crowns and hinges. These parts have undergone critical design reviews with consideration towards geometry, material

selection, cost, and complexity of the mechanism/design. Further information about the individual parts can be found below.

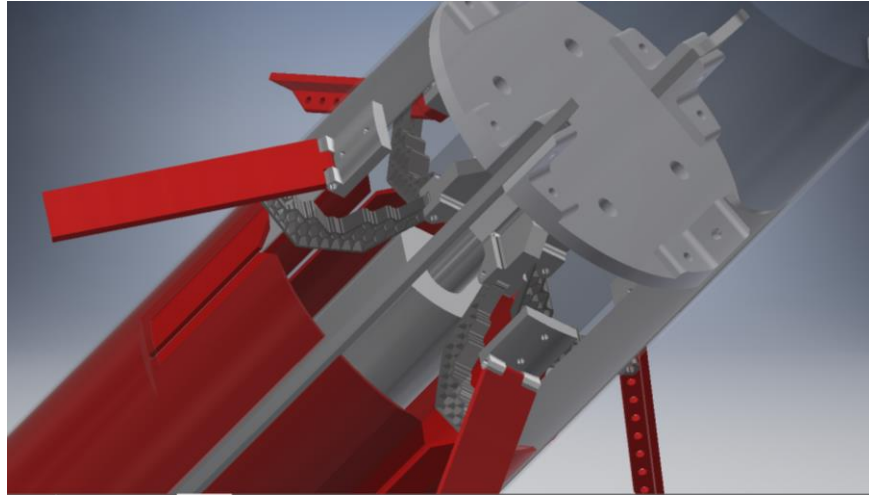

Fig 7-2

7.1.1 Mechanism

The mechanism that is used in the DACS to transfer the direction of motion from linear to rotational is the offset slider-crank mechanism. This system is modeled with a system of equations that correspond with the illustration in figure 7-3 below.

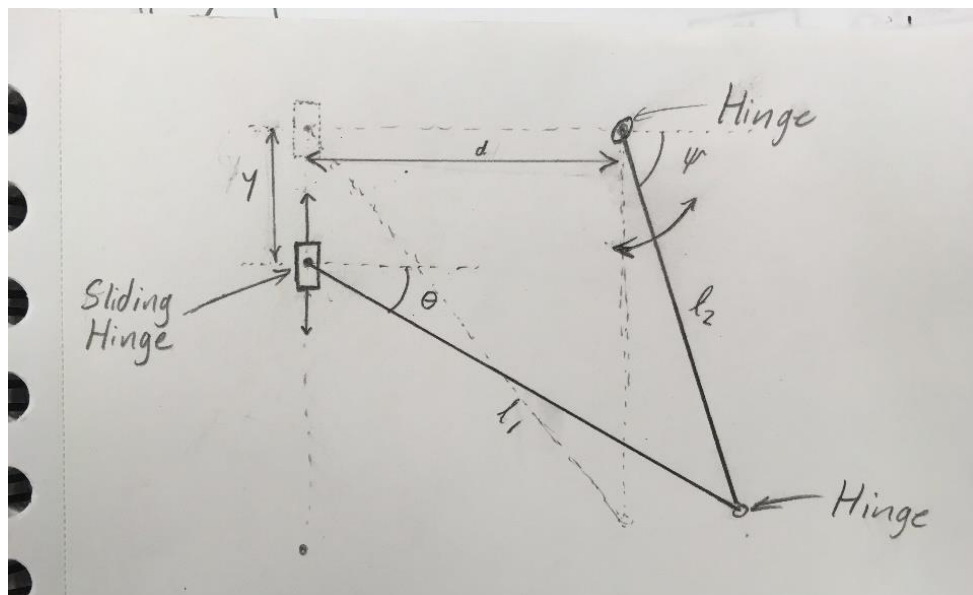

Fig 7-3

With respect to the illustration above, the following system of equations has been derived from the law of cosines to determine the relationship between the slider position y and the angles ψ and Θ .

$$L_1 \cos(\Theta) = L_2 \cos(\psi) + d$$

$$L_1 \sin(\Theta) + y = L_2 \sin(\psi)$$

Using the above equations, we can solve for the angles (θ) and (ψ) with the feedback that is given from the linear actuator (y). Shown below (figure 4) is the CAD model of a quarter of the system, displaying the components that will function as the offset slider crank mechanism.

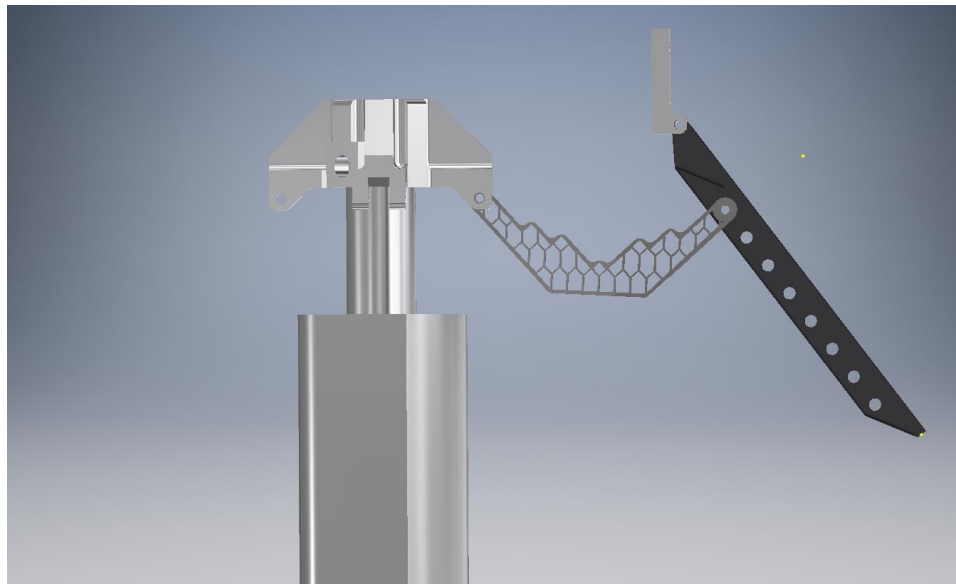

Fig 7-4

7.1.2 Driver

We will be using a Progressive Automations PA-14P-2-150 Actuator, Model# PA-14P with feedback. This has proven to be the most convenient way to control the device because it is capable of providing feedback that will tell the microcontroller the position of the actuator on the stroke. This feedback will then make the system much easier to control, and make modeling a relationship between the position of the actuator and the force of drag acting on the rocket more

7.1.3 Micro-controller/Electronics

7.1.3.1 Arduino UNO

The Arduino Uno will serve as the microcontroller platform that is controlling all of the components of the DACS. This controller will take in feedback from sensors such as an accelerometer, Pressure Sensor, and Potentiometer in the linear actuator. Due to the limitations from the Arduino itself we will be having code the control program in the Arduinos language which could prove to have some limitations as it's much more specific than other more common languages such as C or python. Looking more at the architecture of the Arduino language we can see many similarities which will prove useful as the basic nature of the language shows extreme efficiency when running complex programs if structured correctly.



Fig 7-6

7.1.3.2 Accelerometer

One of the key sensors of the DACS is the Accelerometer. This will take in data and of acceleration and velocity and relay it to the microcontroller. From there it will use the data in a set of calculations to make corrections.

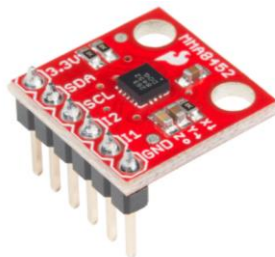

Fig 7-7

7.1.3.3 Pressure Sensor

The Pressure sensor is also a critical component of the DACS, as it will be used to produce real time data of the altitude of the launch vehicle. Ground testing will be done by inducing a change of pressure with either a vacuum chamber or utilizing a shop vac and a box to create a low/high pressure chamber.



Fig 7-8

7.1.4 Logic

The logic that the DACS will use will be predictive in a sense that it will take real time readings and run through calculations and determine what the projected apogee is going to be. After comparing the projected apogee with the goal, the code will be able to identify if it will overshoot or undershoot, and by how much. If the launch vehicle undershoots, then the system will not activate the flaps. However, if it is projected to overshoot, the code will run through more calculations to figure out what the coefficient of drag should be of the launch vehicle in order to bring the apogee down to the target, and then deploy the flaps to induce additional drag and meet the coefficient of drag that is necessary to reach the target. The code will have a set of error statements in upon startup and be programmed with an emergency full open feature that will engage if for any reason, overshooting is detected, and cannot be dynamically corrected. A flow chart that shows the logic is laid in figure 7-9 out for a visual aid. Further description and examples of the code used will be supplied during the FRR as we will have a working system at this point.

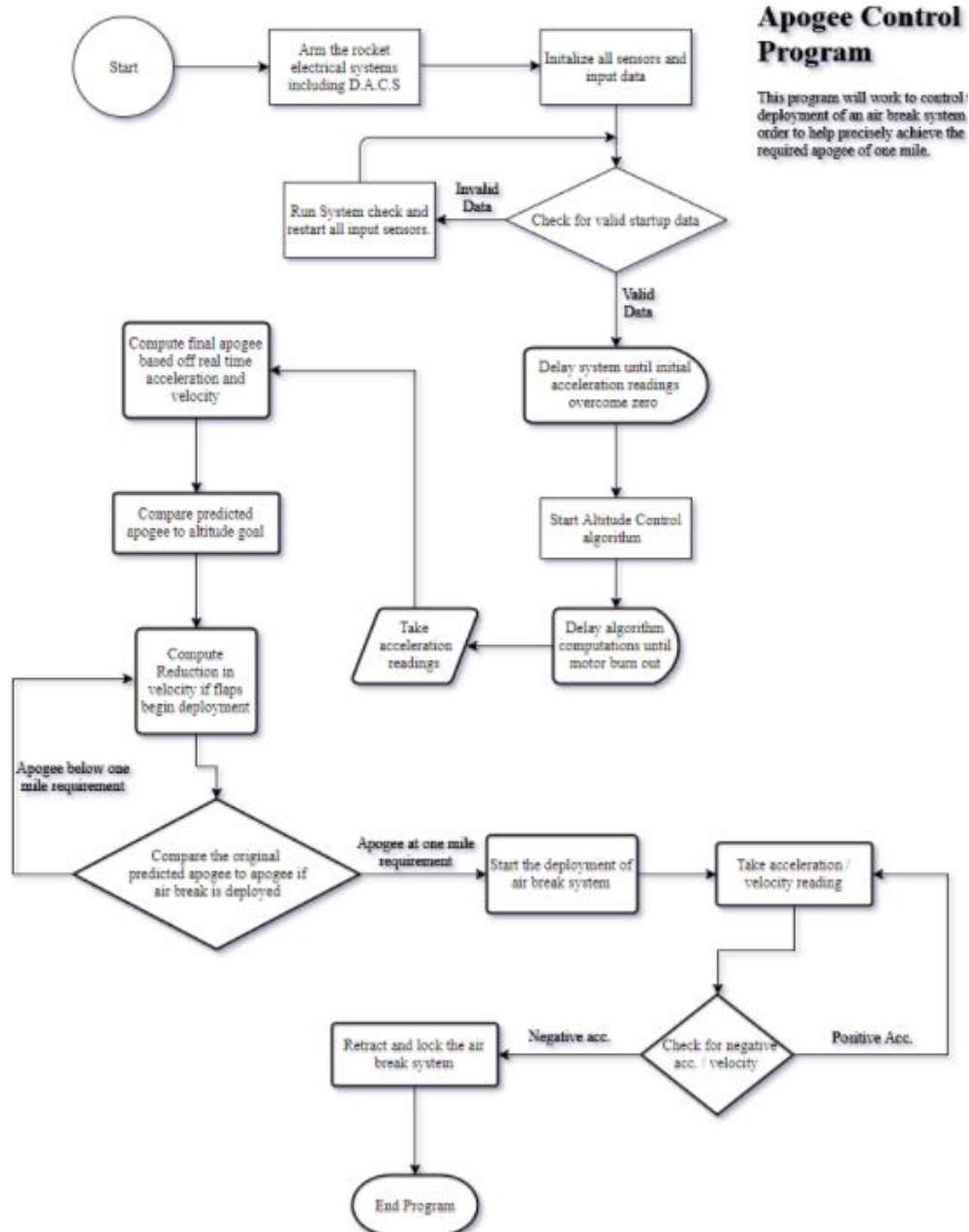
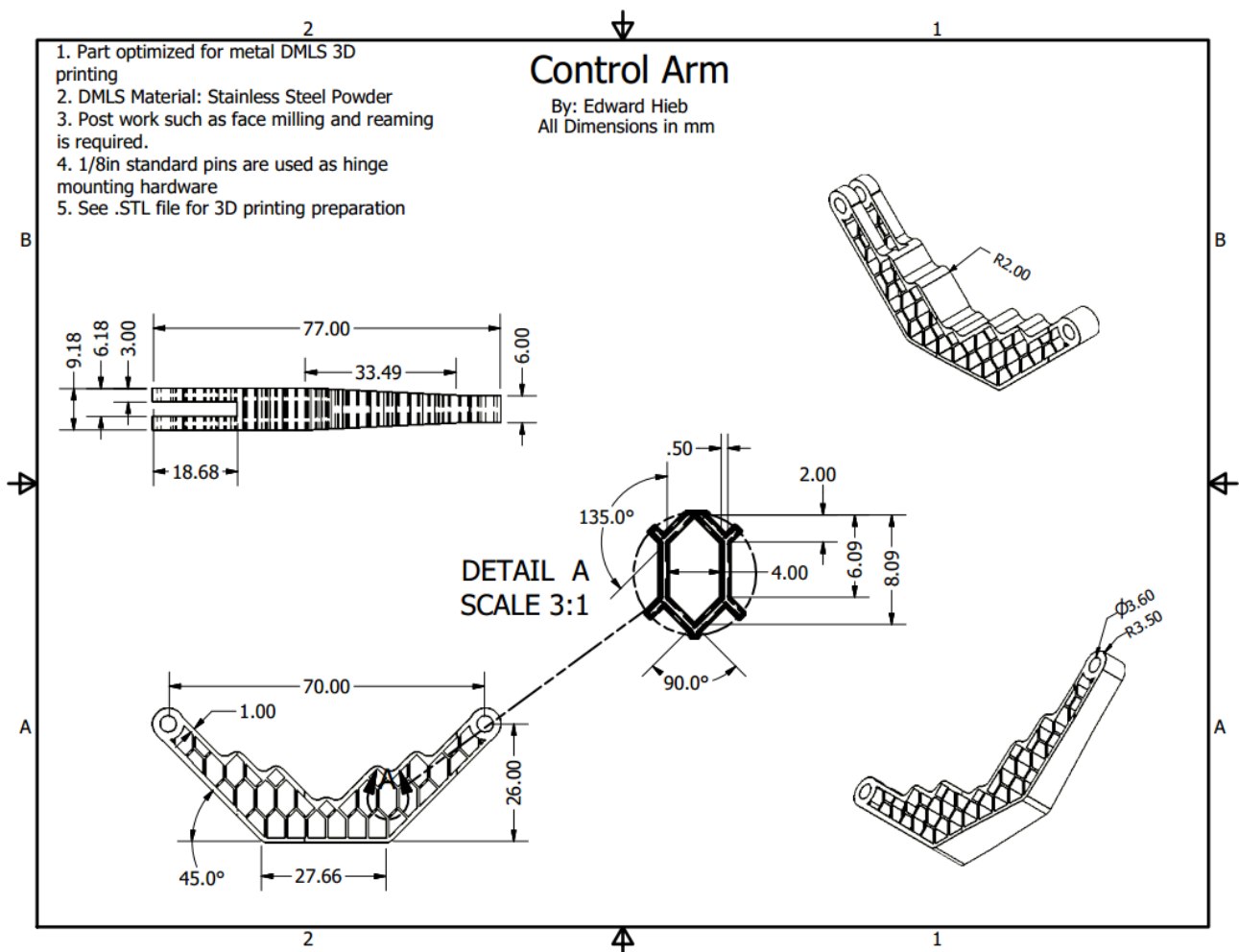

Fig 7-9

7.1.5 Control Arms

The four control arms that will be opening the drag inducing flaps were originally proposed to be either 3D printed out of ABS plastic, or milled out of aluminum. After further consideration and overall strengthening of the DACS system, it has been decided that they will be metal 3D printed using a direct metal laser sintering (DMLS) printer. Using the DMLS additive manufacturing process allows us to design control arms that will be for more efficient with regards

to the strength to weight ratio. Because DMLS builds the part layer by layer, one sheet of fine powder at a time, the design must follow a set of constraints such as; no overhangs greater than 45 degrees, a minimum wall thickness, using the least amount of volume as possible while maintaining high strength geometry, and a design that will tolerate the addition of support material. The support material functions as both a heat sink for the freshly welded metal, as well as a build surface for overhanging geometry. The design that will be printed uses a lattice structure that contains a repeating pattern of extended hexagons. See figure 7-10 for a detailed drawing of this part.



7.1.6 Crown

The DACS “crown” is the central hinge that will transfer motion from the linear actuator to the four control arms. It is to be milled out of aluminum and have four holes for 1/8inch pins that will serve as hinges.

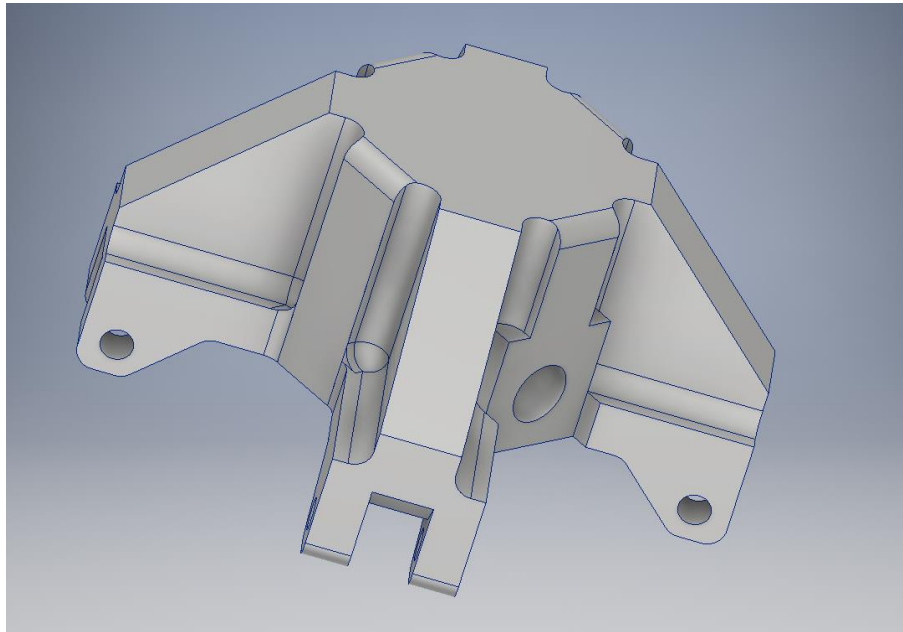

Fig 11

The hinges on the crown will be created by reaming out one side of the metal hinge, and then tapping threads into the other and then running a custom threaded pin into it.

7.1.7 Air Buffer

Due to the large windows that will be cut into airframe, at the event of flap opening, a large amount of turbulent flow will be generated inside of the airframe beneath the drag flaps. Because it is necessary to have a window for the control arms to open the drag flaps, it is unavoidable to eliminate the openings, however it is possible to minimize the amount of air that will be drawn into the airframe by including an inserted shield, or buffer. The air buffer is going to reflect that of a cup with slits for the reinforcement ribs and a space for the control arms, while providing proper shielding to promote laminar flow along the DACS body, beneath the drag flaps. The buffer is shown in figure 7-12.

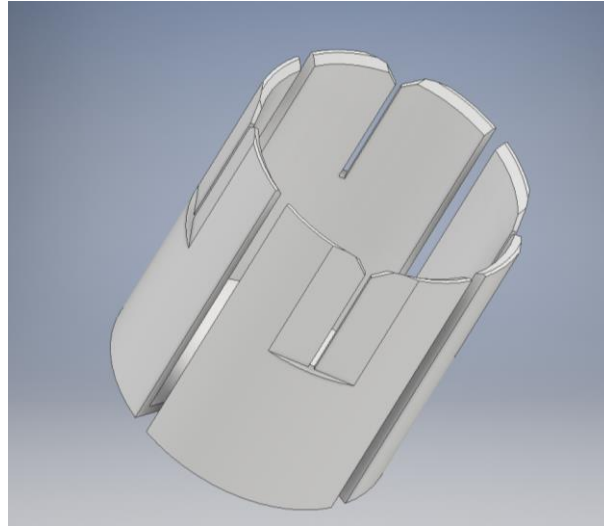

Fig 12

7.1.8 Hinges

The four main hinges for the DACS will be mounted directly to the inside of the airframe using nuts and bolts, through 2 holes that are cut into the face of the hinge, with the hinge receiving end seated inside of the cut window holes. The detailed drawing of the hinge will be referred to when milling the parts out of 6061 Aluminum and is shown in figure 7-13.

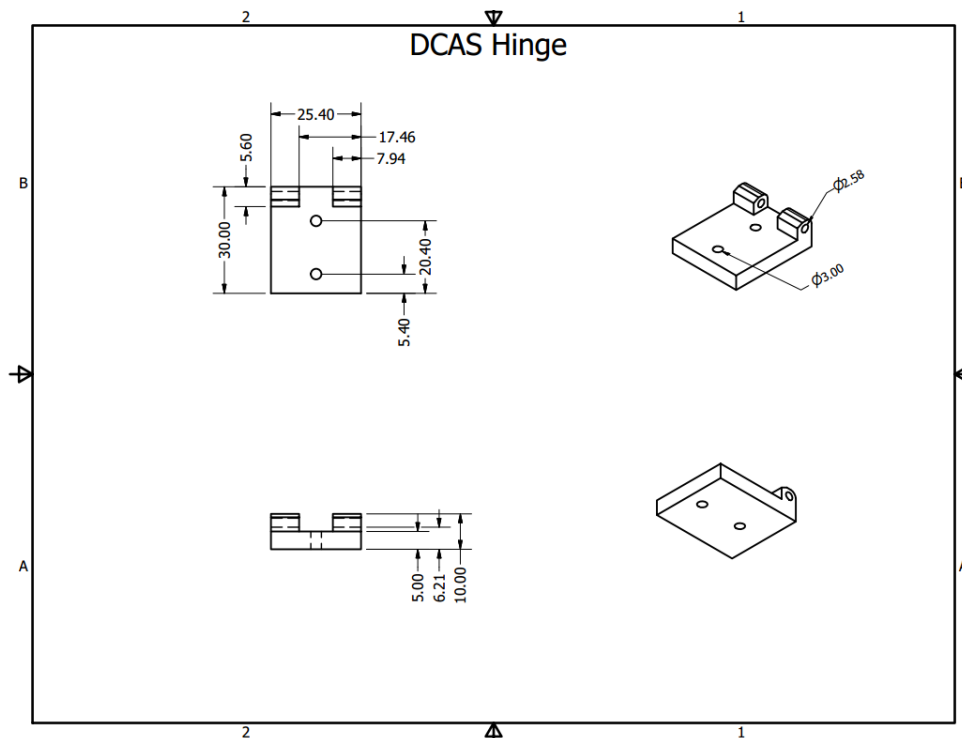

Fig 13

7.1.9 Flaps

The Flaps of the DACS will undergo the brunt of the aerodynamic drag force and must be built to withstand the extreme conditions that they will face. The material that has been selected for the flaps is 1/8th in thick G10 fiberglass. This has been proven to be incredibly strong, (see material properties table) and frequently used in high powered rocketry. While this material presents a potential hazard when working with it, it is the same material that we will use for our fins, and thus will be proficient in both safely handling and fabrication. (See safety section for more information on G10 handling) The G10 will be both the surface of the flap as well as the spine and hinges that connect to the receiving hinge on the rocket airframe, and the control arm. It will be laminated and drilled out to create holes for pins, and then bonded together using epoxy fillets.

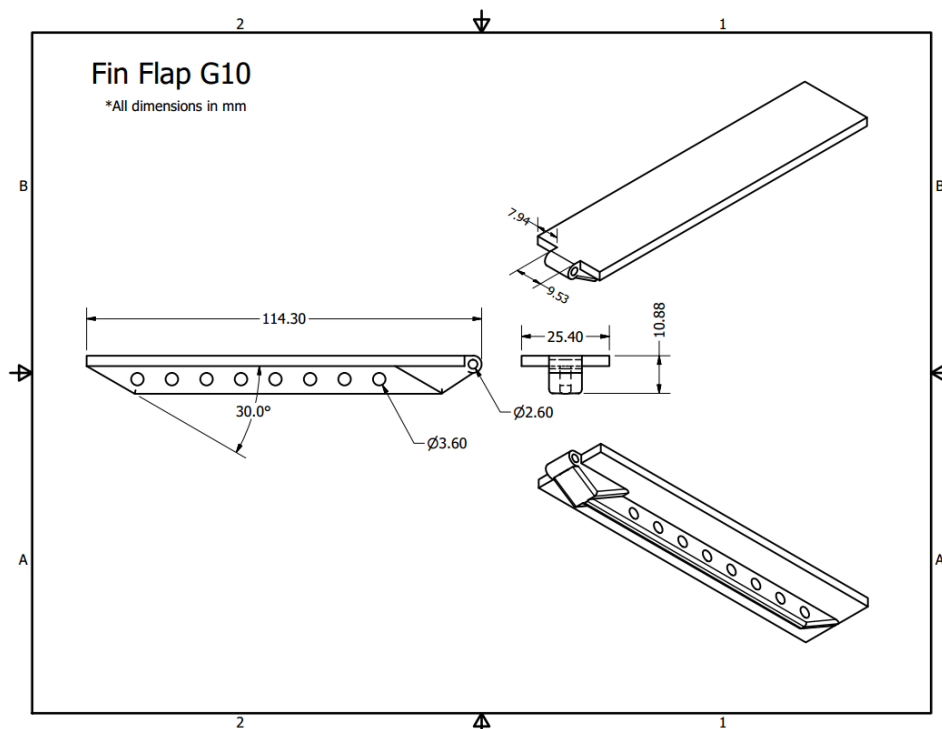

Fig 7-14

7.1.10 Structure and Reinforcement

The Structure of the DACS has raised concern due to the cutting of slats in the side of the airframe to inset the drag flaps. This can be seen in the detailed drawing as the holes where the control arms protrude from. Though Blue-Tube 2.0 is an incredibly strong material, the holes would decrease the structural integrity of the airframe and create potential for failure. The best way to avoid this problem is to reinforce the inside of the airframe inside of the DACS section with fiberglass. Using either vertical sections of G10 and epoxy fillet along the internal walls, or applying a sheet of fiberglass to the inside the airframe, or both. The G10 ribs will be made out of the same material as the fins which is 3/16-inch-thick and have a 3/16-inch hole for mounting hardware to an aluminum bulkhead. The ribs have been designed and tested using an FEA simulator figure 7-15 and will hold strong to the forces it will see during main parachute deployment

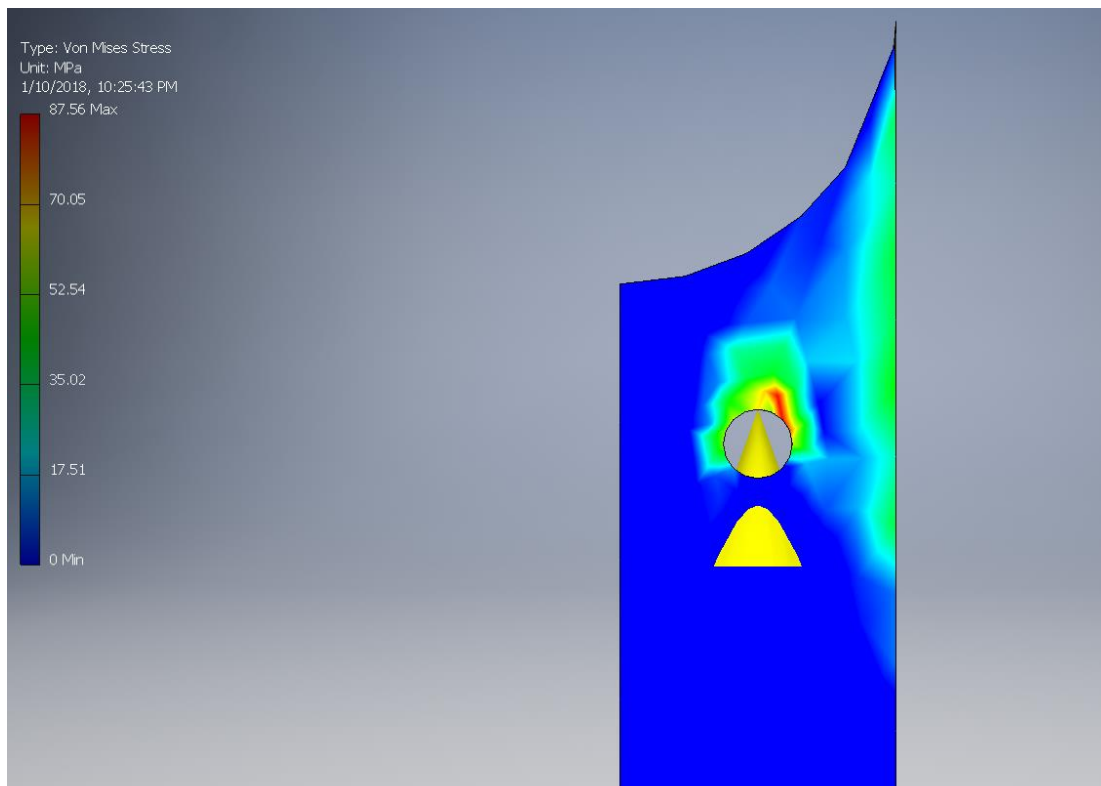

Fig 7-15

The amount of force that will be applied to the bulkhead of the DACS is 6000 Newtons at main parachute deployment that will be dispersed through the four ribs if the shock chord does not absorb any of the energy. Each of the four ribs will see a force of 1500 Newtons, and this load will create a stress of 87.56MPa. Because the tensile strength of the G10 is 262MPa, there is a factor of safety of 3 in a worst-case scenario in which the shock chord does not cushion the load.

7.1.11 Bulkheads

The base of the DACS will be mounted directly to the lower bulkhead, which will be made out of ½ inch to ¾ inch plywood. The top bulkhead will be made out of 6061 Aluminum and be mounted to the reinforcement ribs using nuts and bolts.

7.2 Wind Tunnel Experiment

7.2.1 Independent Variable: Flap Angle

The angle flap deployment is a variable that will be changed by taking 5-degree steps starting from 0 and maxing out at approx. 58~55 degrees. This will be the variable that is controlled by the system during flight.

7.2.2 Control Variables

7.2.2.1 Wind Speed

The velocity in this equation will be the velocity of the air flowing past the D.A.C.S in the wind tunnel, (which will be the independent variable) that we are able to control with the wind tunnel. From this velocity we will be able to determine the dynamic pressure, which is the equation below.

$$q = \frac{\rho V^2}{2}$$

$q = \text{Dynamic Pressure}$

$V = \text{Velocity of Fluid}$

$\rho = \text{Density of Fluid}$

7.2.2.2 Mounting System

We will be utilizing an internal Force balance in the form of a sting mount. The sting mount will be mounted to the top end of a solid slender bar, and this bar have a moveable hinge that can be adjusted to various points along the length of the bar. The bottom end of the bar will have a hole that is attached to a rope that will be connected to the digital fish scale, which we will read the force of drag from the air. To increase the accuracy of the mount there is a windshield welded to the mounting plate, meant to reduce the force of drag induced by the air flowing past the slender rod. The mounting plate will be bolted to the bottom of the wind tunnel. This mounting system will be made fabricated in the Mechanical Engineering shop out of mild steel. The mounting tube will be made of plastic, most likely to be made of ABS plastic.

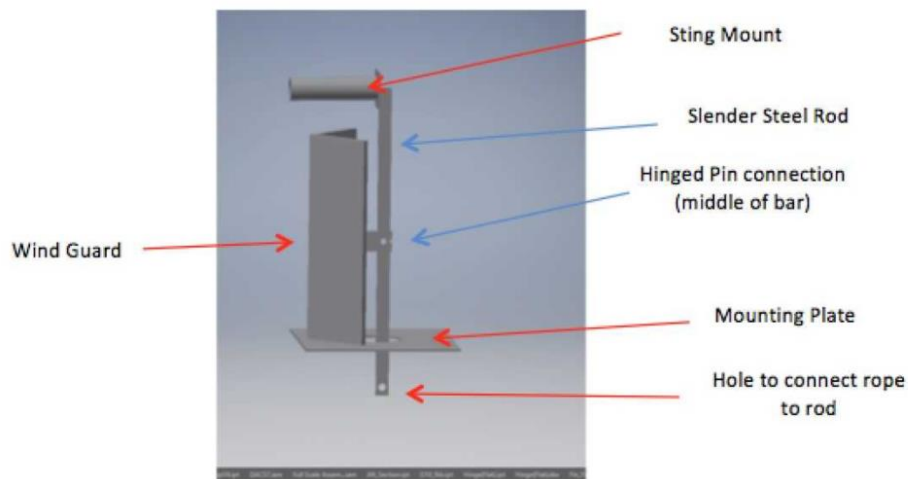

Fig 7-16

7.2.3 Dependent Variable

7.2.3.1 The Force of Drag

The force of drag will be measured using a sting mount, and this mount will be used to not only hold the device and keep it stationary during the experiment, making sure that we get accurate readings of the force. There will be a digital fish scale measuring the drag force. We will get an array of drag forces values that will be dependent on the flap angle.

7.2.3.2 Coefficient of Drag

The coefficient of drag is an output that will be calculated using force data collected in the experiment. It can be calculated using the following equation. *This equation, and its notation, were rearranged came from the NASA reference picture

$$C_d = \frac{F_d}{\frac{1}{2} * A * \rho * V^2}$$

$C_d =$ *Coefficient of Drag*

$F_d =$ *Force of Drag*

$A =$ *Area of Cross – flow*

$V =$ *Velocity of Flow*

$\rho =$ *denisty of fluid (air in this case)*

This Force will be found experimentally using the fish scale, and this measured force value will be used to calculate the Coefficient of drag on the D.A.C.S.

7.2.4 Control Setup

The DACS will be modeled using the same geometry as the final design and mounted to a section of the rocket that will have the same 6” diameter with the same nosecone as the final rocket. This will ensure that the testing environment will be as close to the final launching environment as possible. The mounting technique will be a sting mount and it will be designed for use with ¼ - 20 bolts on 1” centers. The first step when setting up for testing is to calibrate the force balance. We will calibrate the scale by checking its accuracy by hanging a weight of 5lbs on it and seeing how accurate it is. Using a fish scale, a slender rigid bar, a hinge, and a sting mount we will be able to measure the force of drag will do this. The sting mount will be used mount the rocket and make sure that it is snugly in place and will not slide.

7.2.5 Testing

The experiment will be run with the D.A.C.S placed in the tunnel and the nose cone attached to the top of the D.A.C.S. system, and will be attached to the sting mount, the spring scale calibrated, and the wind tunnel will run at various speeds. The experiment will ultimately provide data that is necessary to calculate the coefficient of drag of the flaps. Once the force of drag and dynamic pressure is experimentally determined, we can then calculate the coefficient of drag. Because we were able to calculate the Coefficient of drag on the rocket, we can then make a relationship between the angle of flaps and the Force of drag due to the D.A.C.S system. The calculated values will then be plotted, and we will be curve fit the data that we get from the experiment. The curve will then be incorporated into a control system to determine the angle of opening that will provide the necessary coefficient of drag generated by the D.A.C.S that is necessary to slow the launch vehicle down in order to achieve a target apogee.

7.2.6 Verification of Results

We will verify the results and accuracy of our coefficient of drag, using a plot of the Reynolds number versus the Coefficient of drag of our D.A.C.S. We're hoping that the maximum Reynolds number possible from the wind tunnel is in the region of bottoming out on the Reynolds Number v.s. Coefficient of Drag graph. We're unable to confirm these results due to the speed limitation of the wind tunnel, but the apogee height can be determined from the equations that we drew up earlier and those will be used to verify our experiment in the wind tunnel. The coefficient of drag is one of the most unknown things in this whole launch of the rocket, and if we can get an accurate approximation of coefficient of drag, we can more accurately predict our height of apogee by calculations. Also if we can get a coefficient of drag in the wind tunnel that is similar to the coefficient of drag on open rocket, we can have more faith in the simulation.

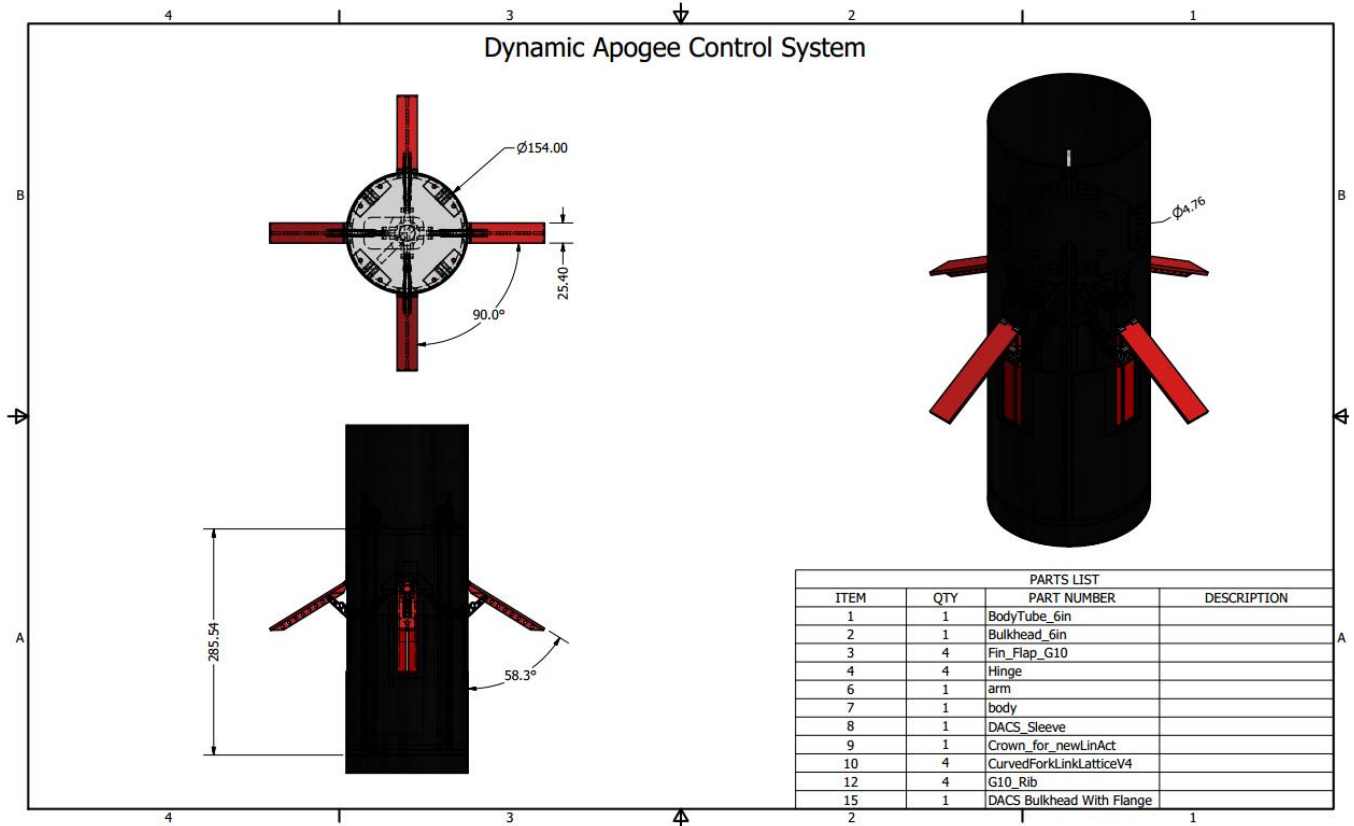

Fig17

7.2.7 Safety Considerations

Safety is a large factor when working with experiments. It is extremely important to be aware of your surroundings and potential hazards/accidents that could occur during testing. In order to prevent such accidents from happening our team will ensure that the model is designed and built to handle wind speeds up to 45m/s, which is the limitation of the wind tunnel. The mounting fixture will also be robust enough that it will not fail under the applied load, and thus would Upon experiment start-up, we will run the tunnel at multiple dynamic pressures, starting with the lowest setting and finally reaching the maximum setting. This procedure is to verify that the system is stable at variable speeds before subjecting it to the maximum. The team is completing/completed safety training (Shop/Studio Safety Awareness, Safety Awareness, Laser Safety, and Hazardous Communications) to further our understanding of proper procedures and to make sure that everyone can operate and use the wind tunnel.

7.2.8 Required Instrumentation

- Sting Mount
- Slender Rod and hinge
- 25 lb Digital Fish Scale
- Pitot tube

Appendix A – Payload Detailed Drawings and Schematics

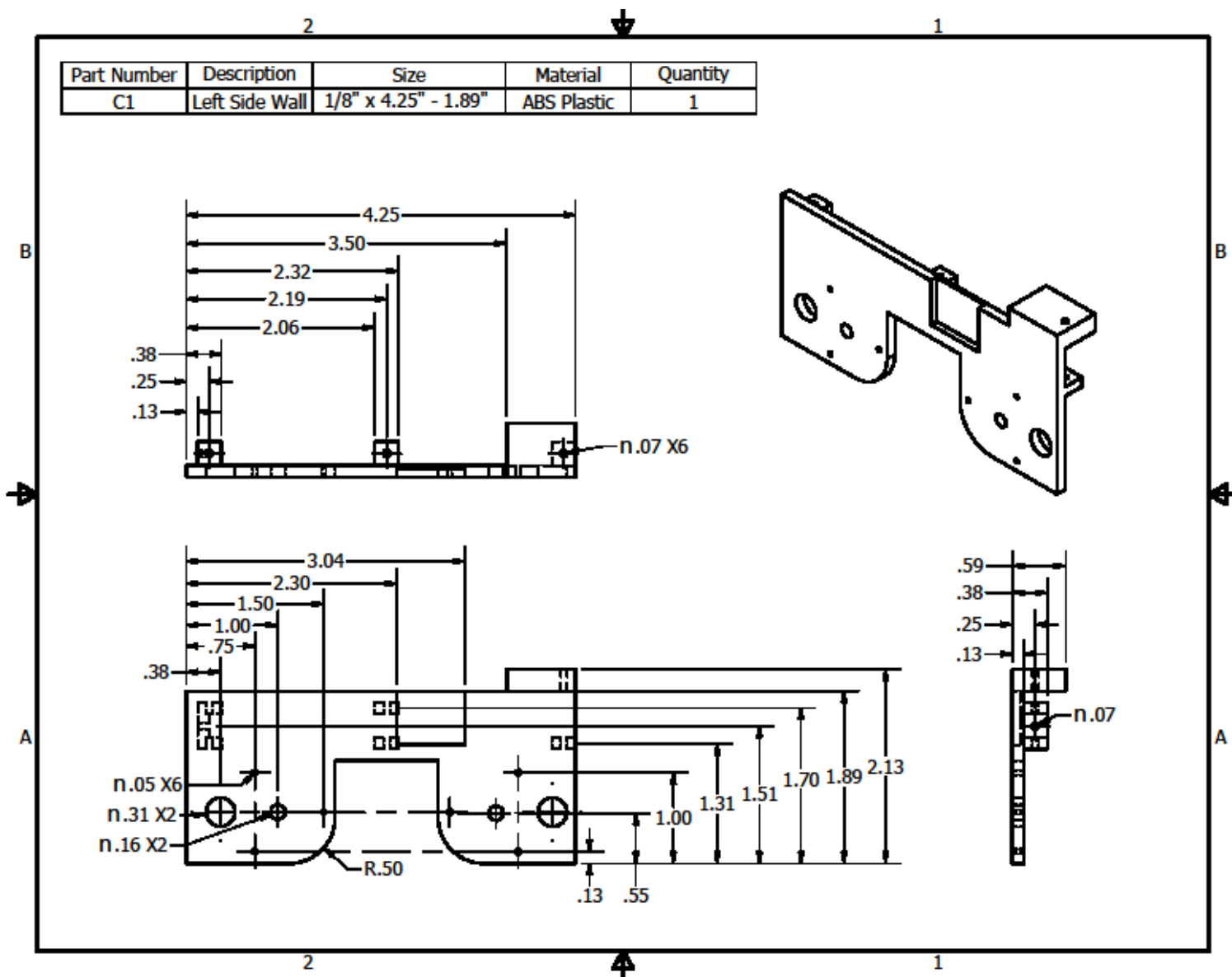

Figure A-1: Chassis Left Panel

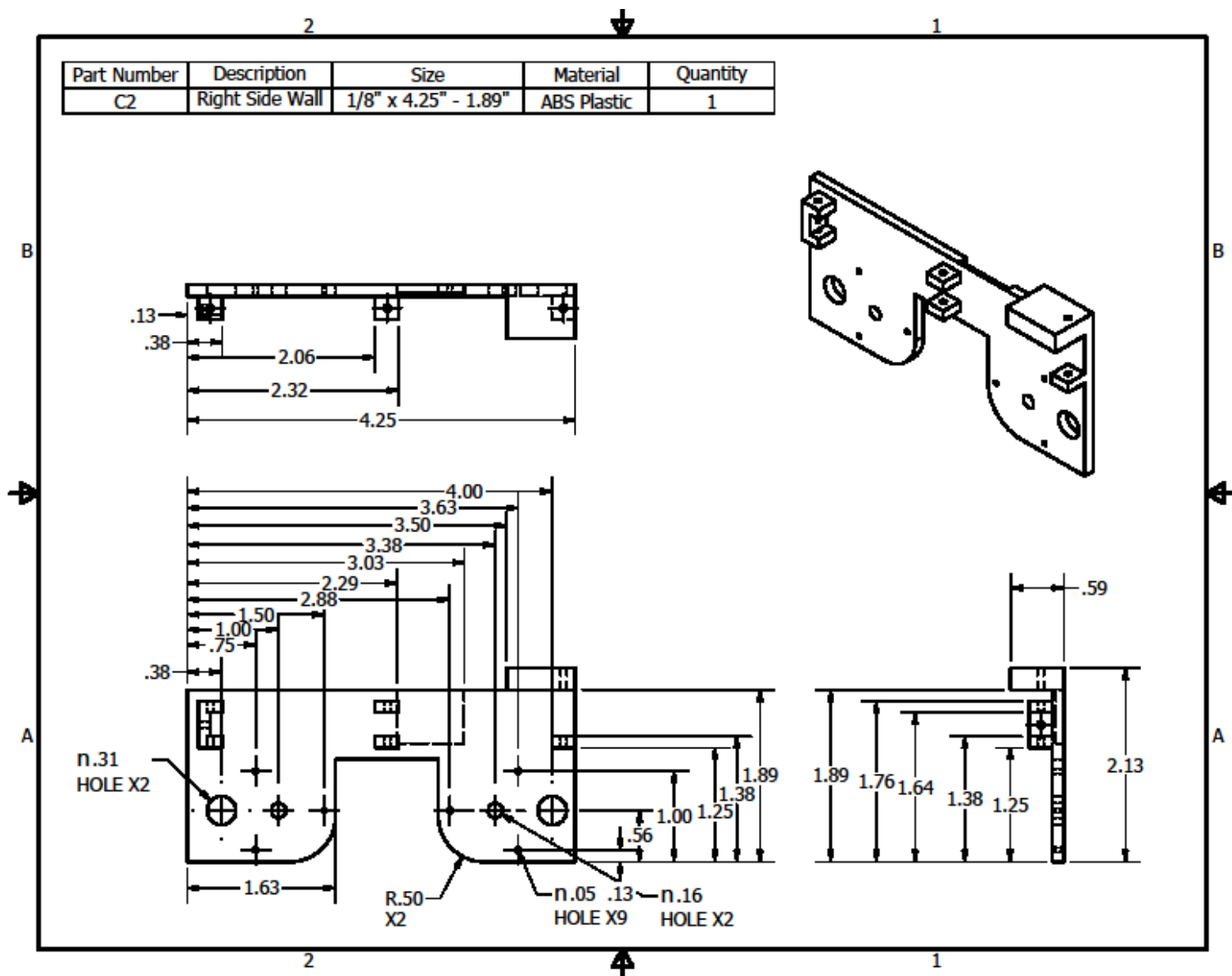

Figure A-2: Chassis Right Panel

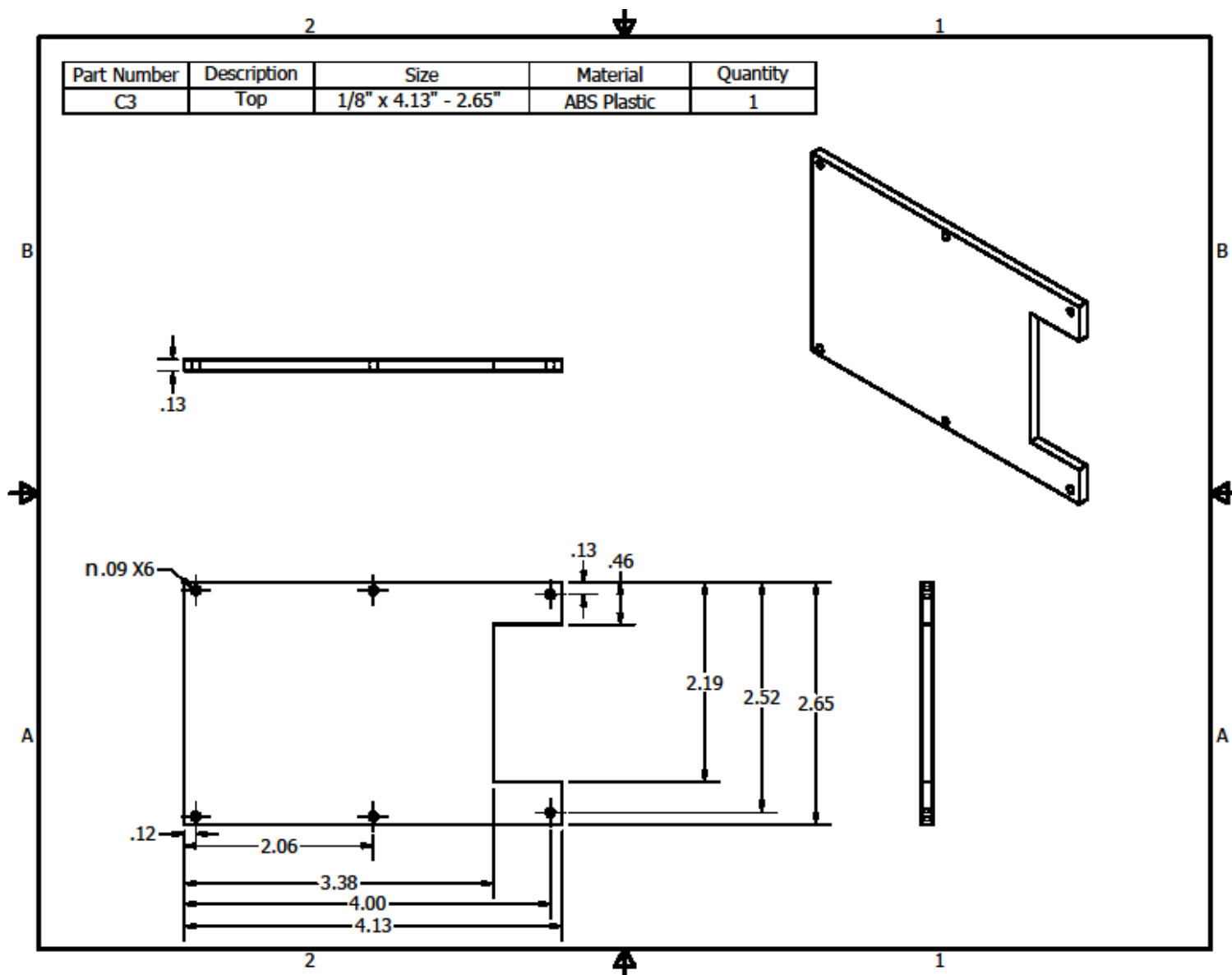

Figure A-3: Chassis Top Panel

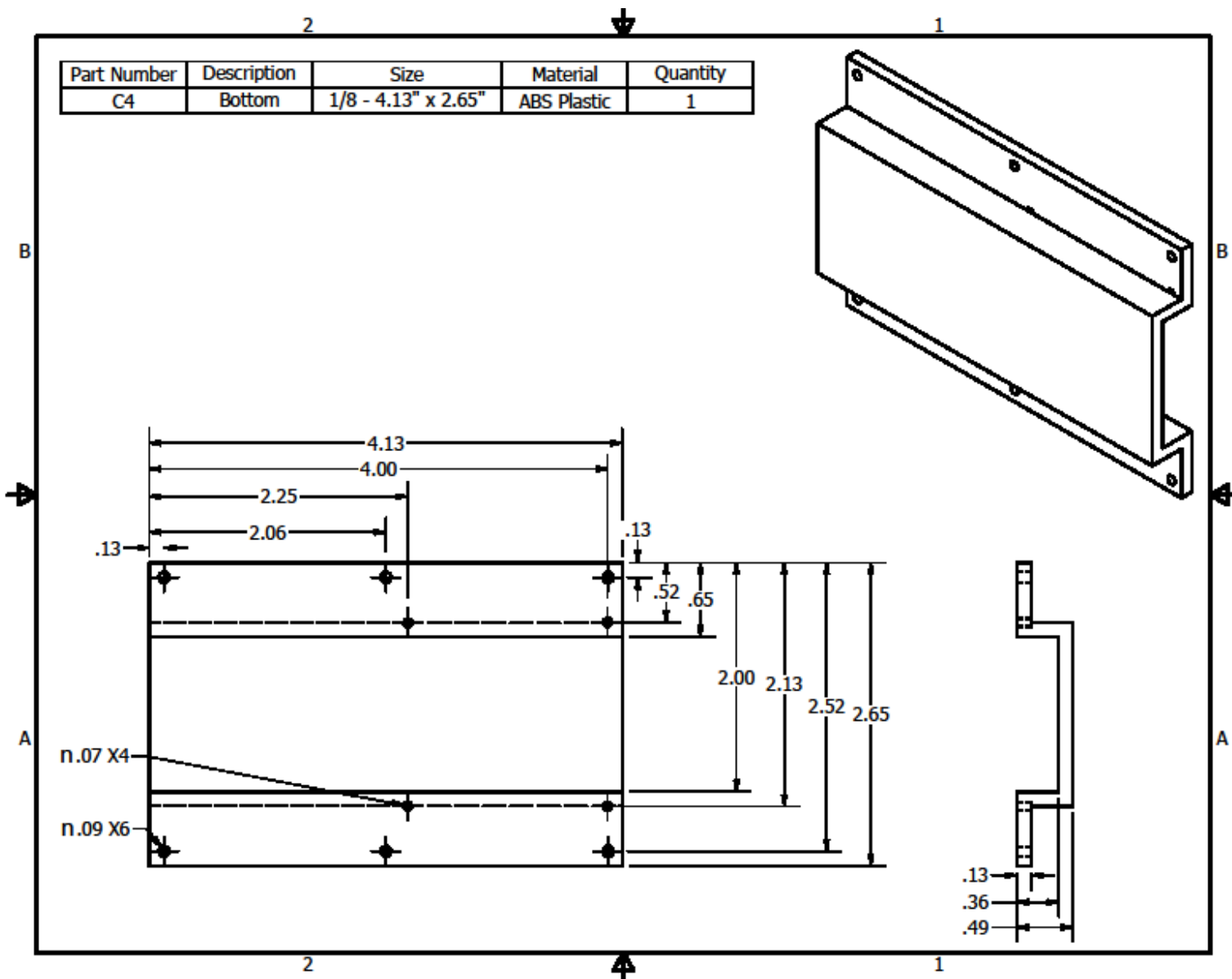

Figure A-4: Chassis Bottom Panel

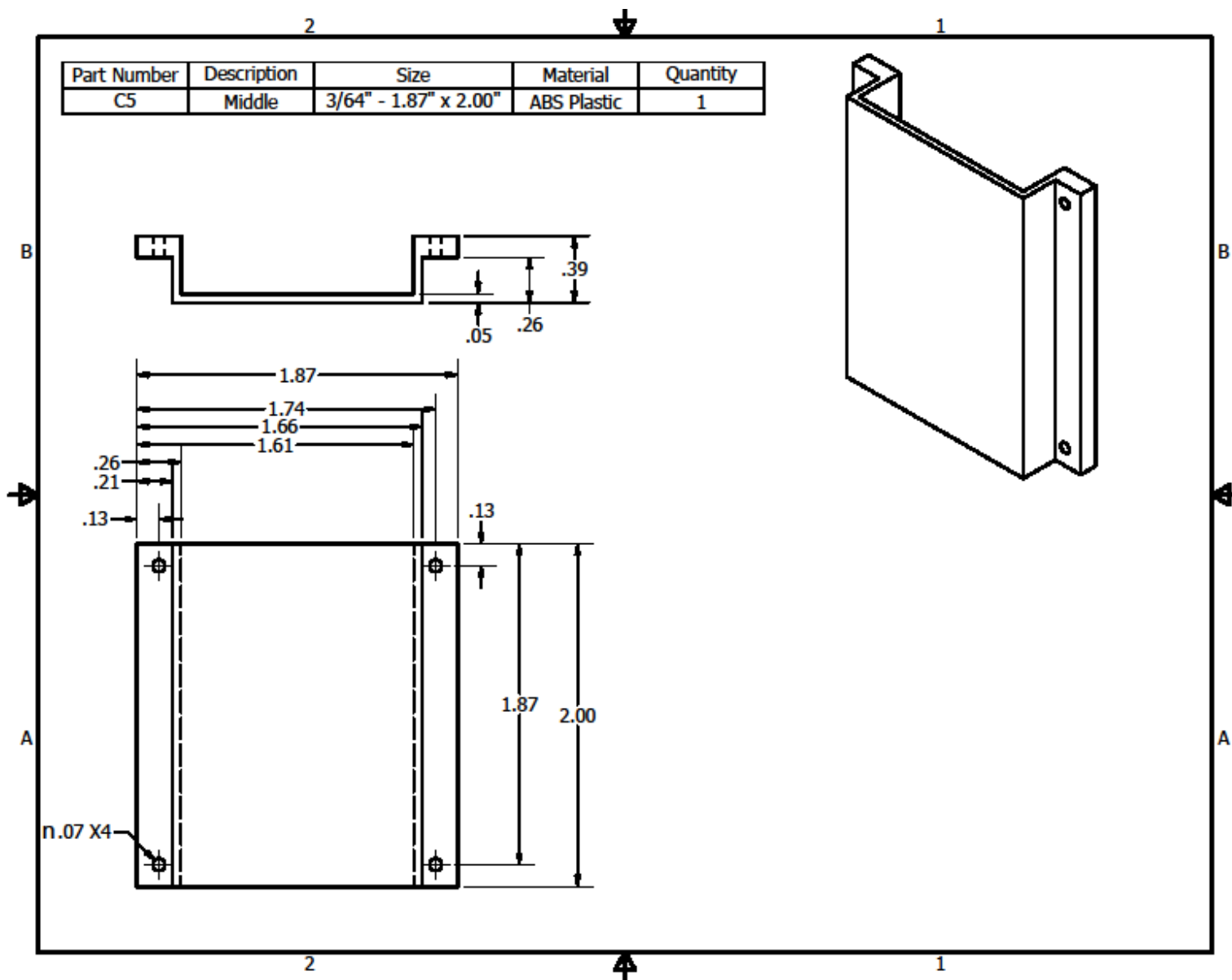

Figure A-5: Chassis Middle Panel

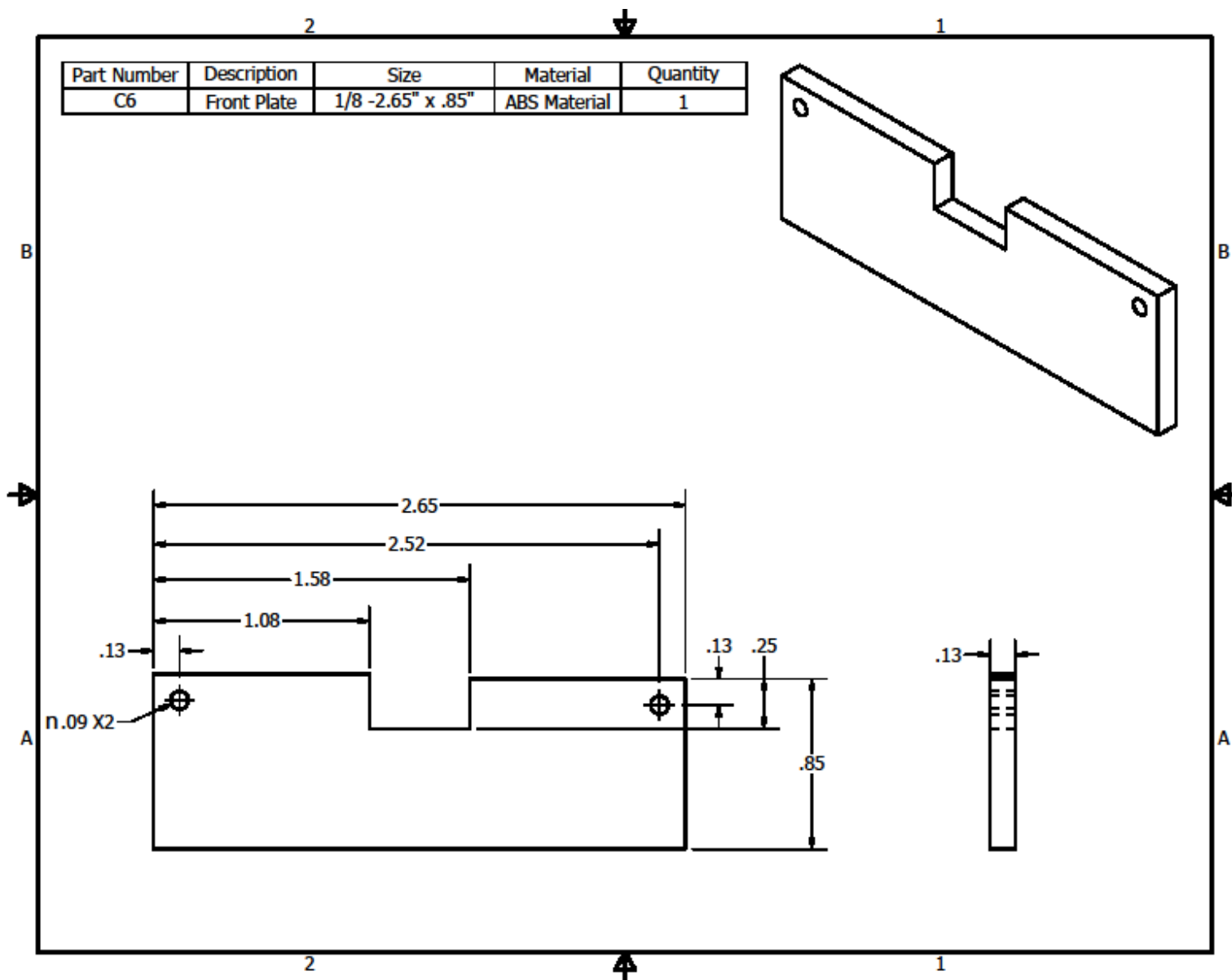

Figure A-6: Chassis Front Plate

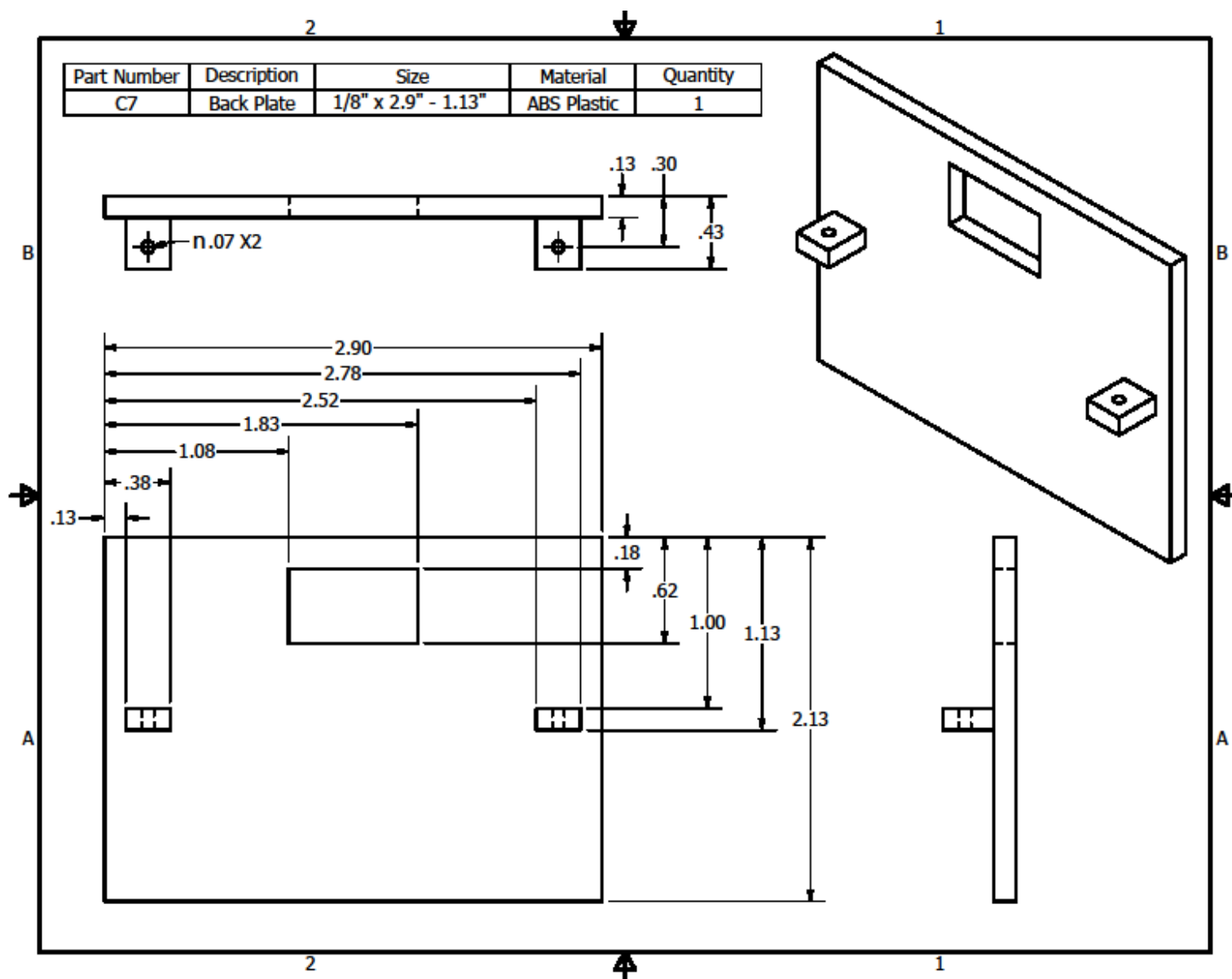

Figure A-7: Chassis Back Plate

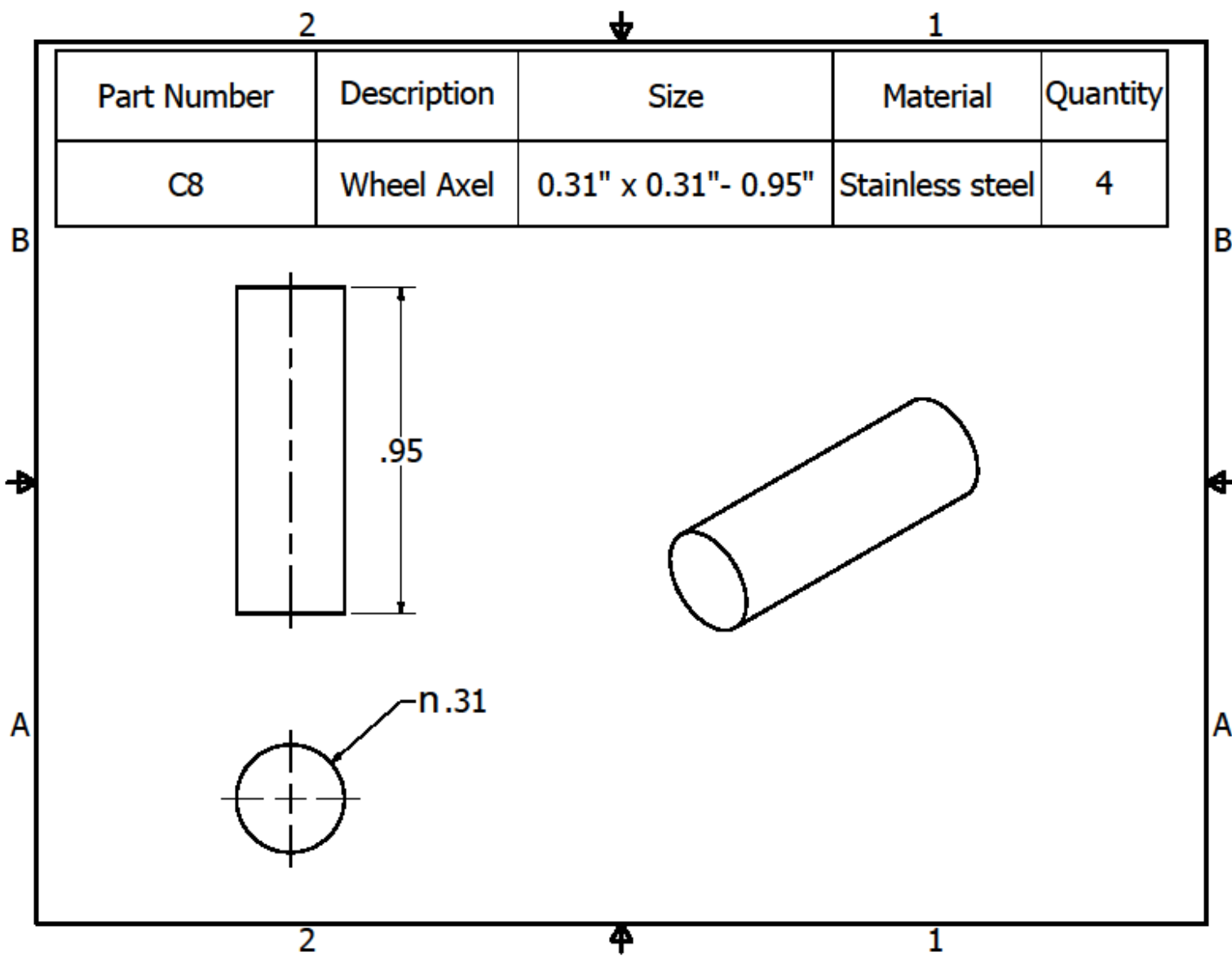

Figure A-8: Wheel Axle

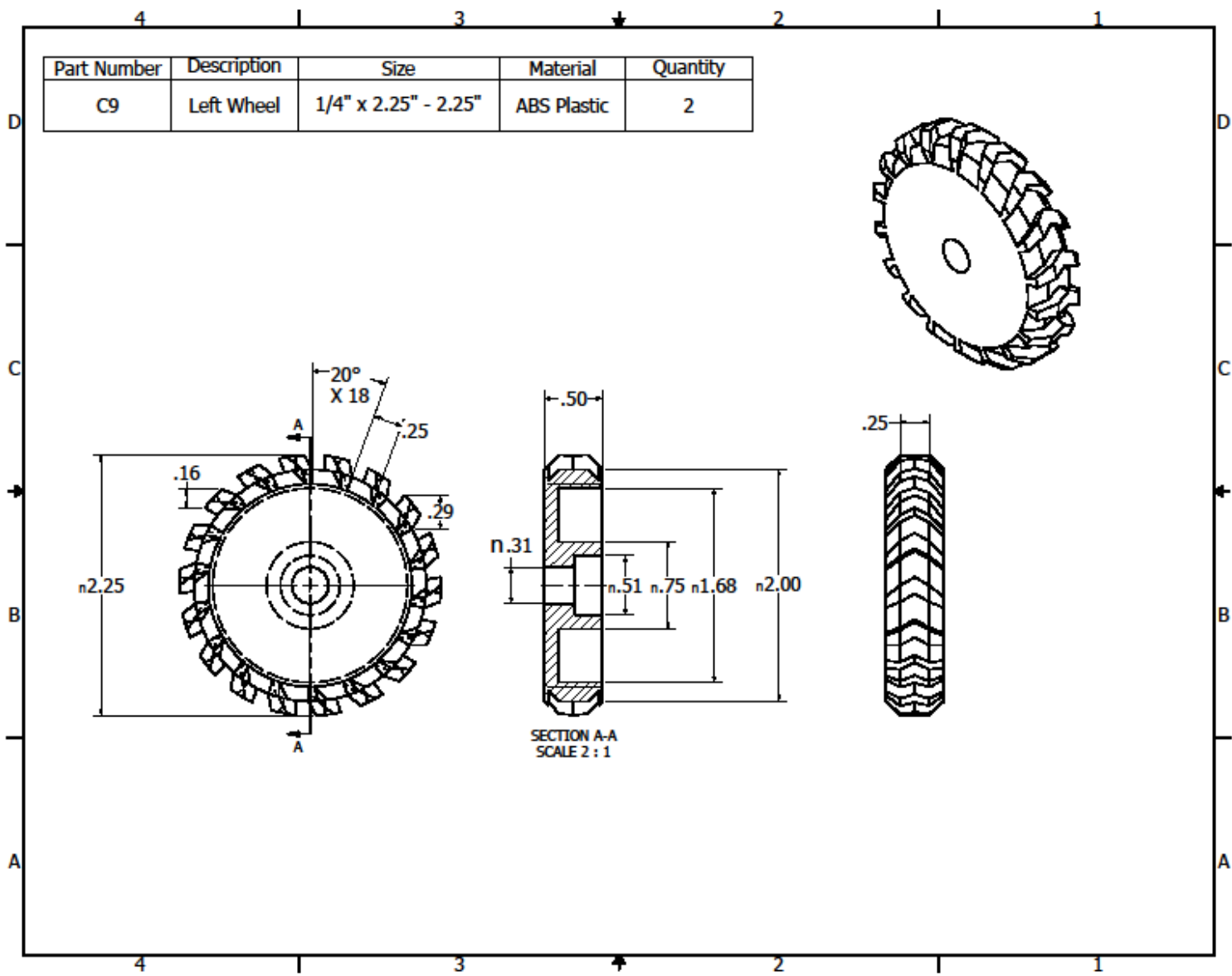
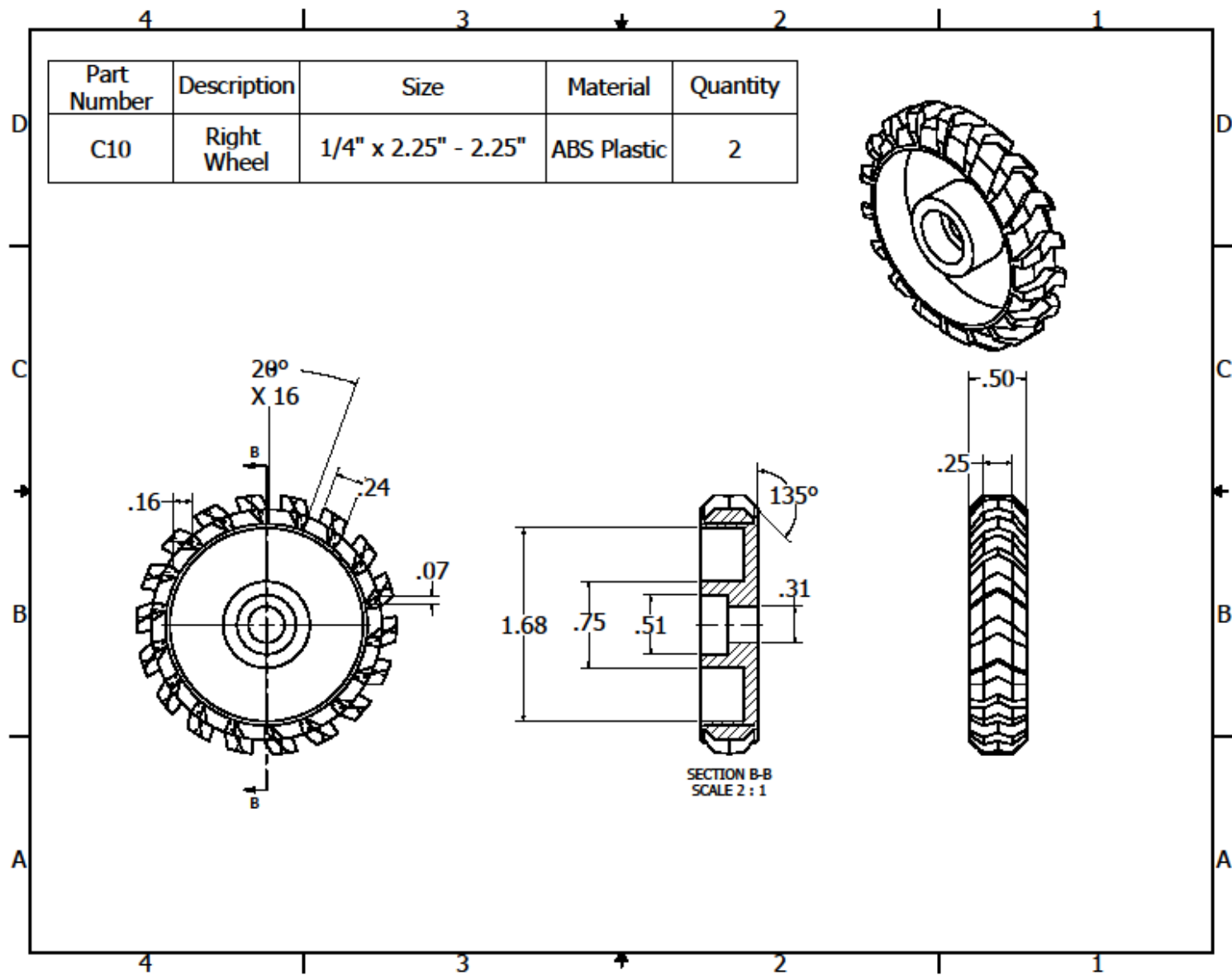

Figure A-9: Left Wheel



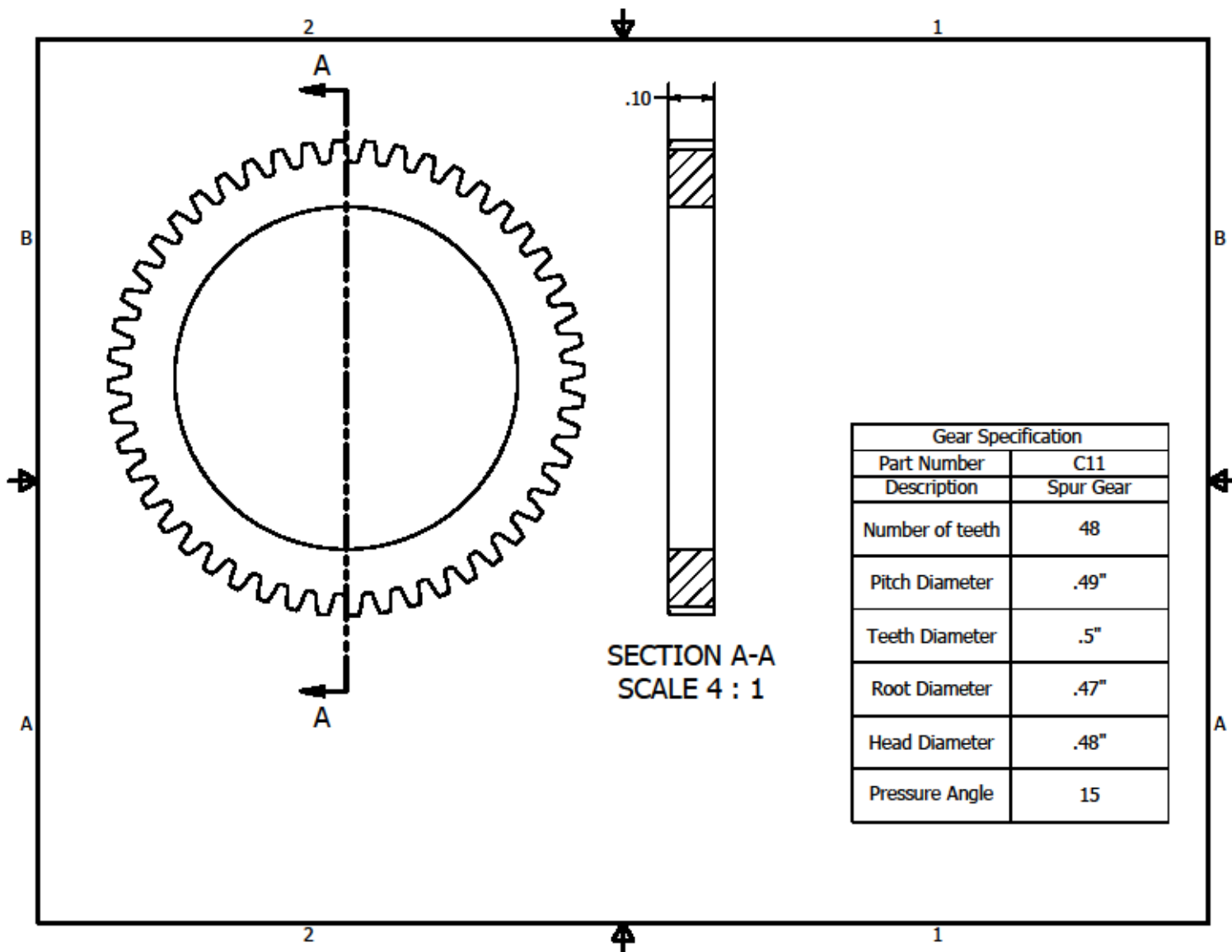

Figure A-11: Spur Gear

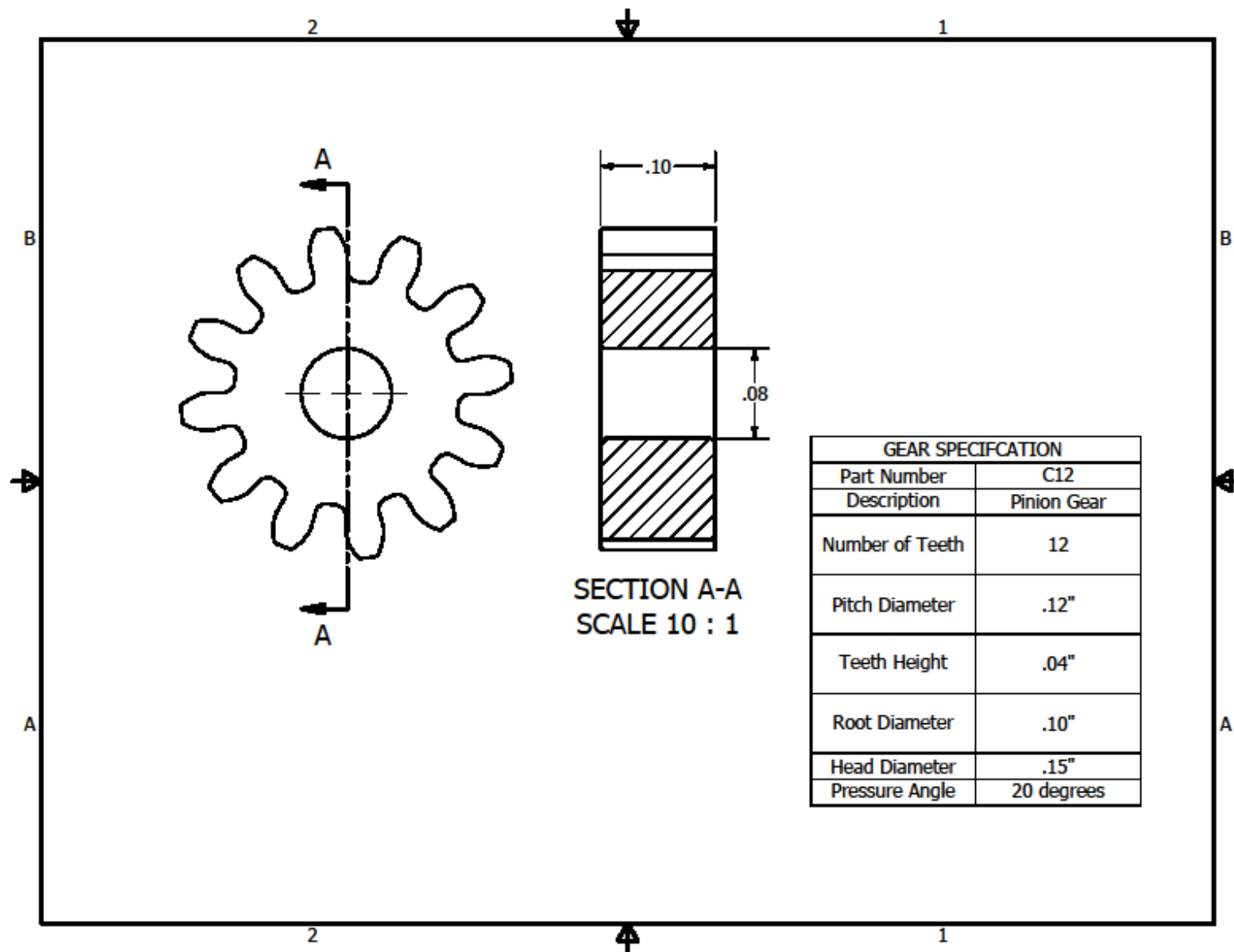

Figure A-12: Pinion Gear

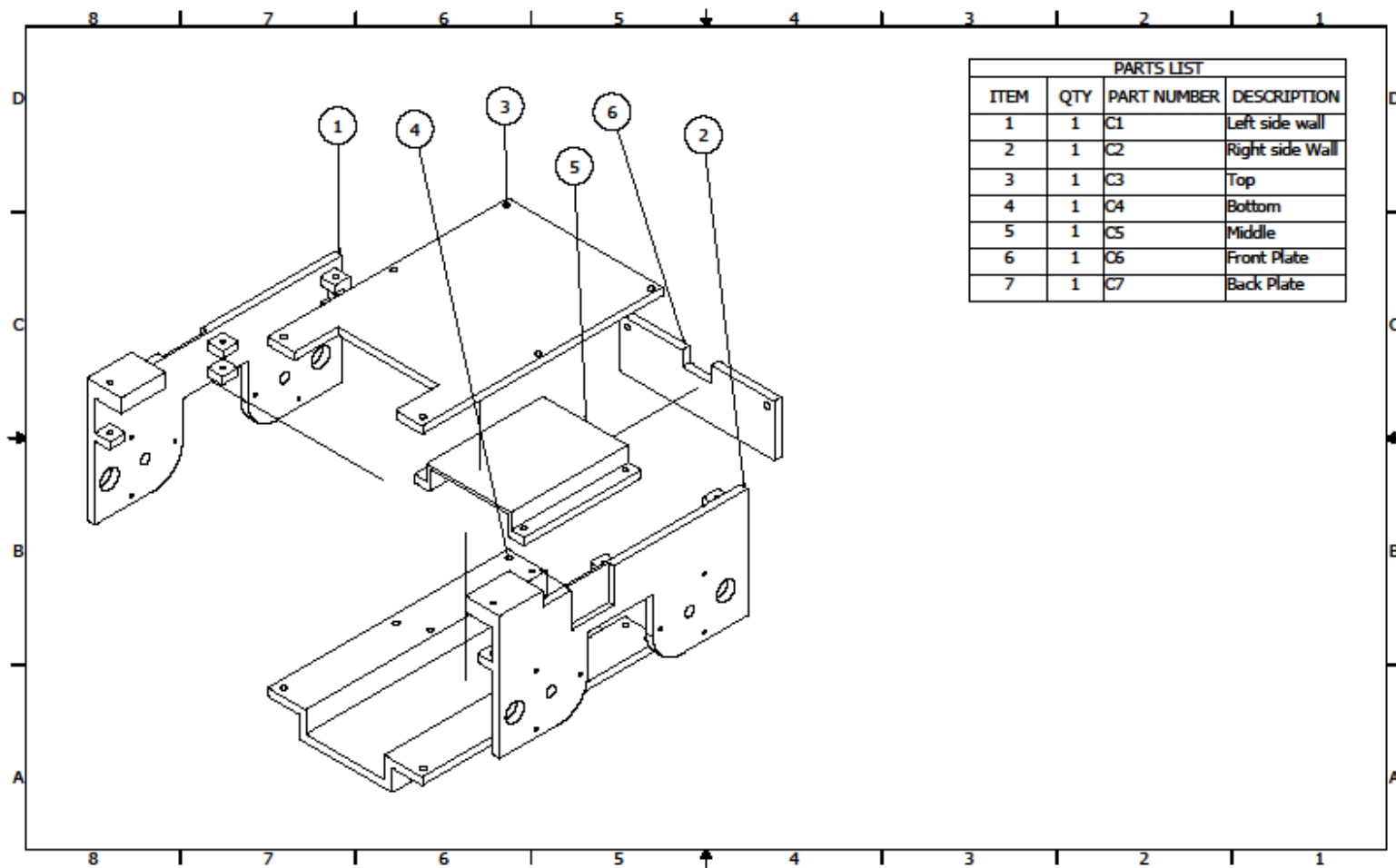

Figure A-13: Chassis Assembly

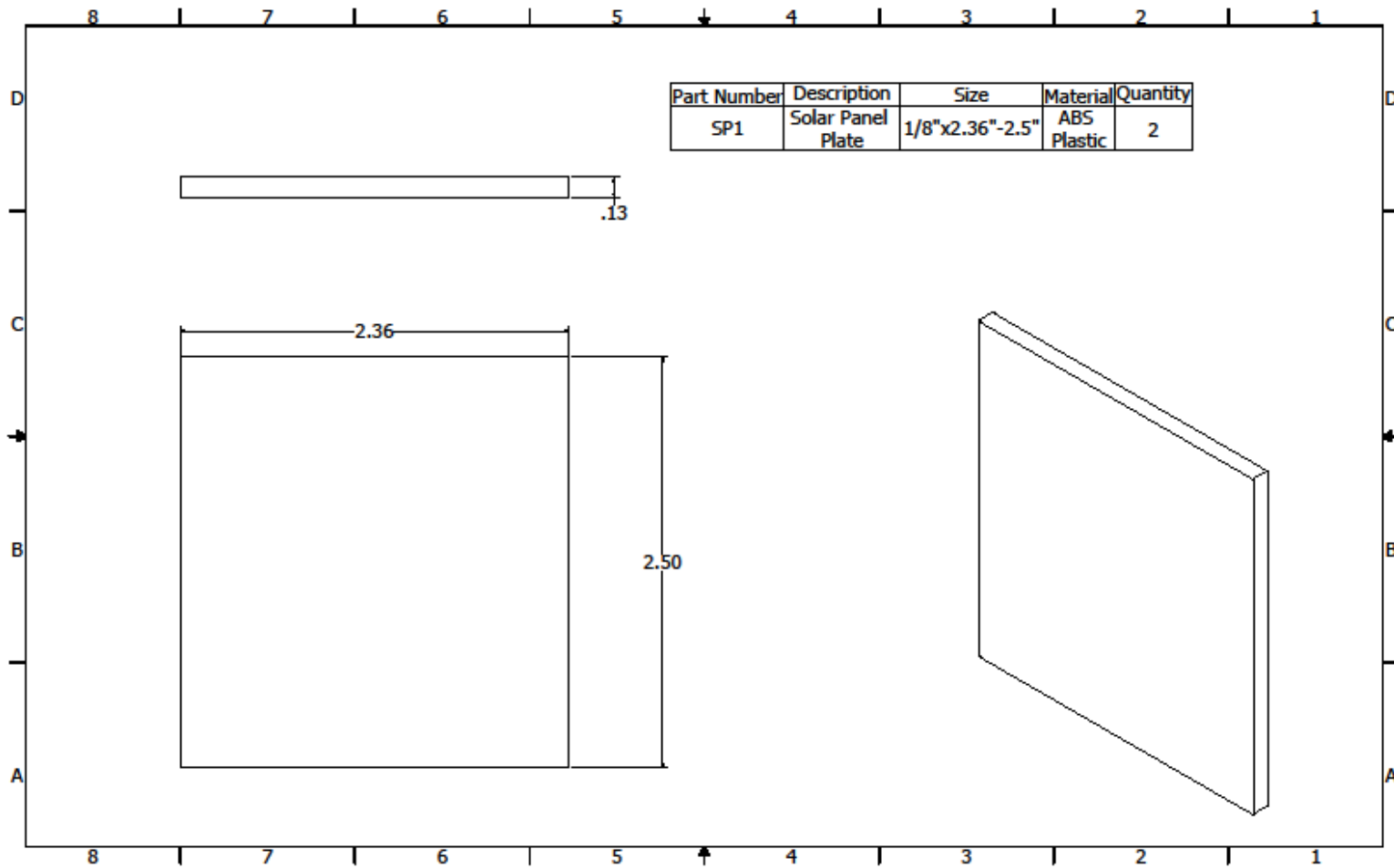

Figure A-14: Solar Panel Plate

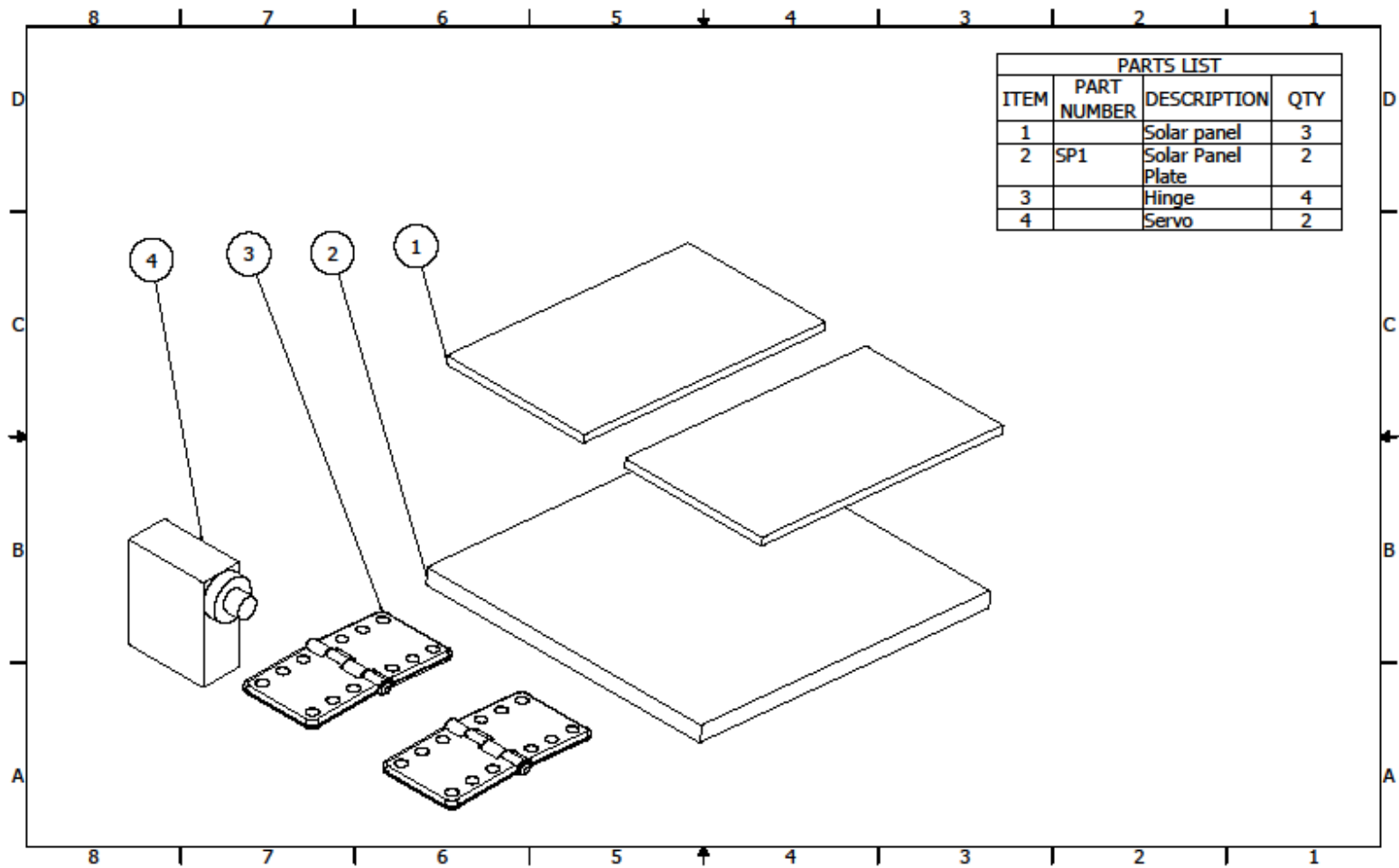

Figure A-15: Solar Panel Deployment Assembly

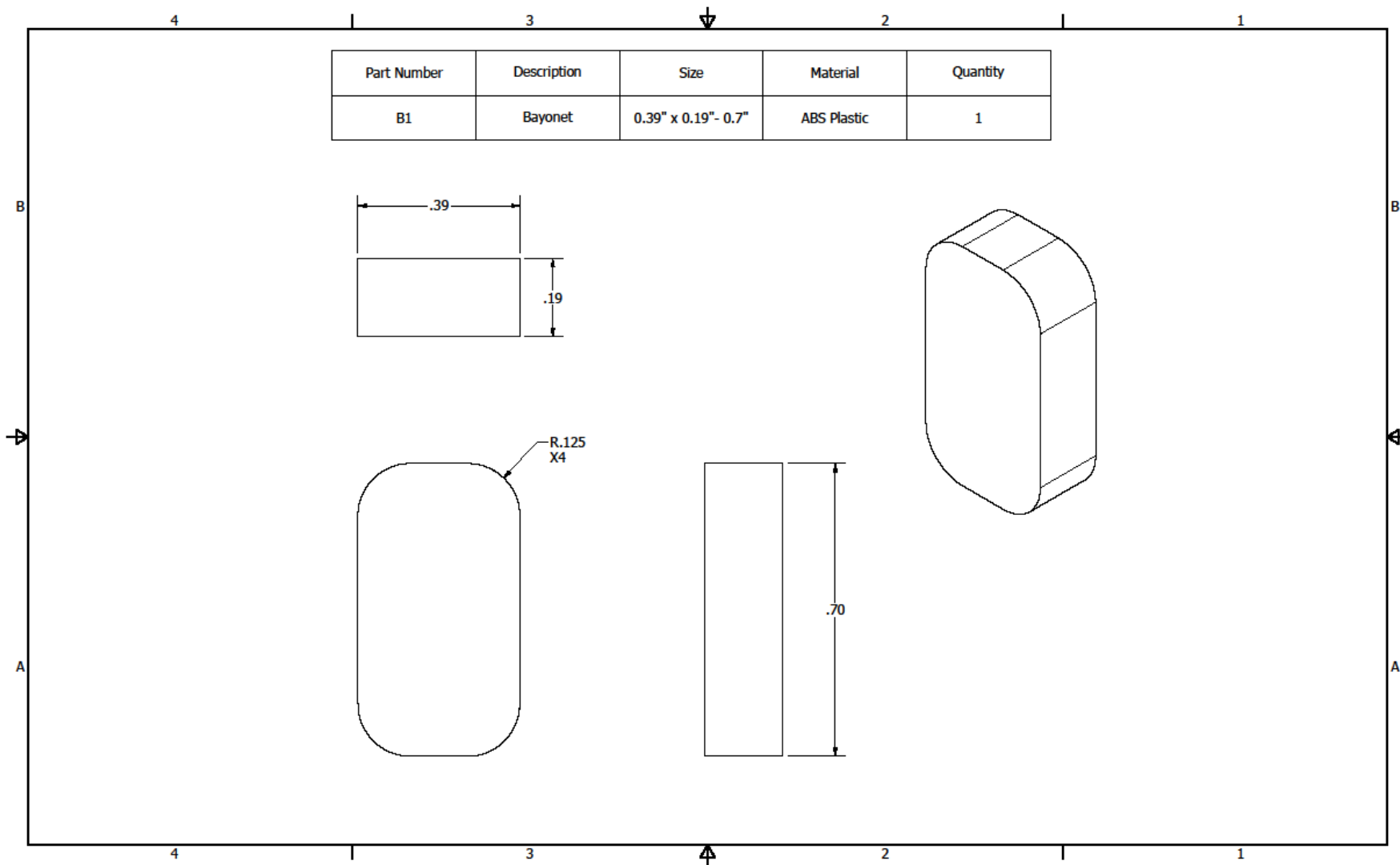

Figure A-16: Bayonet

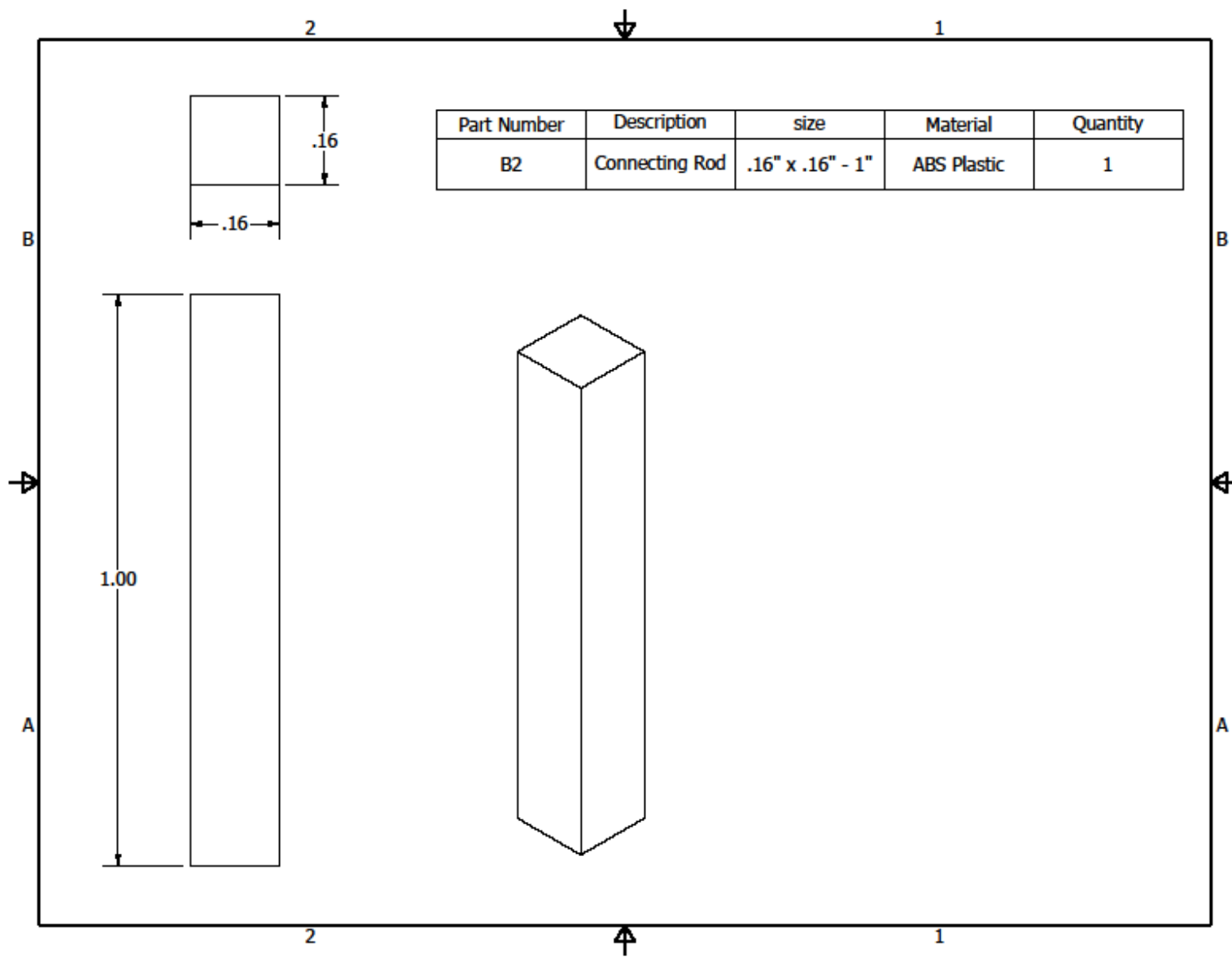

Figure A-17: Connecting Rod

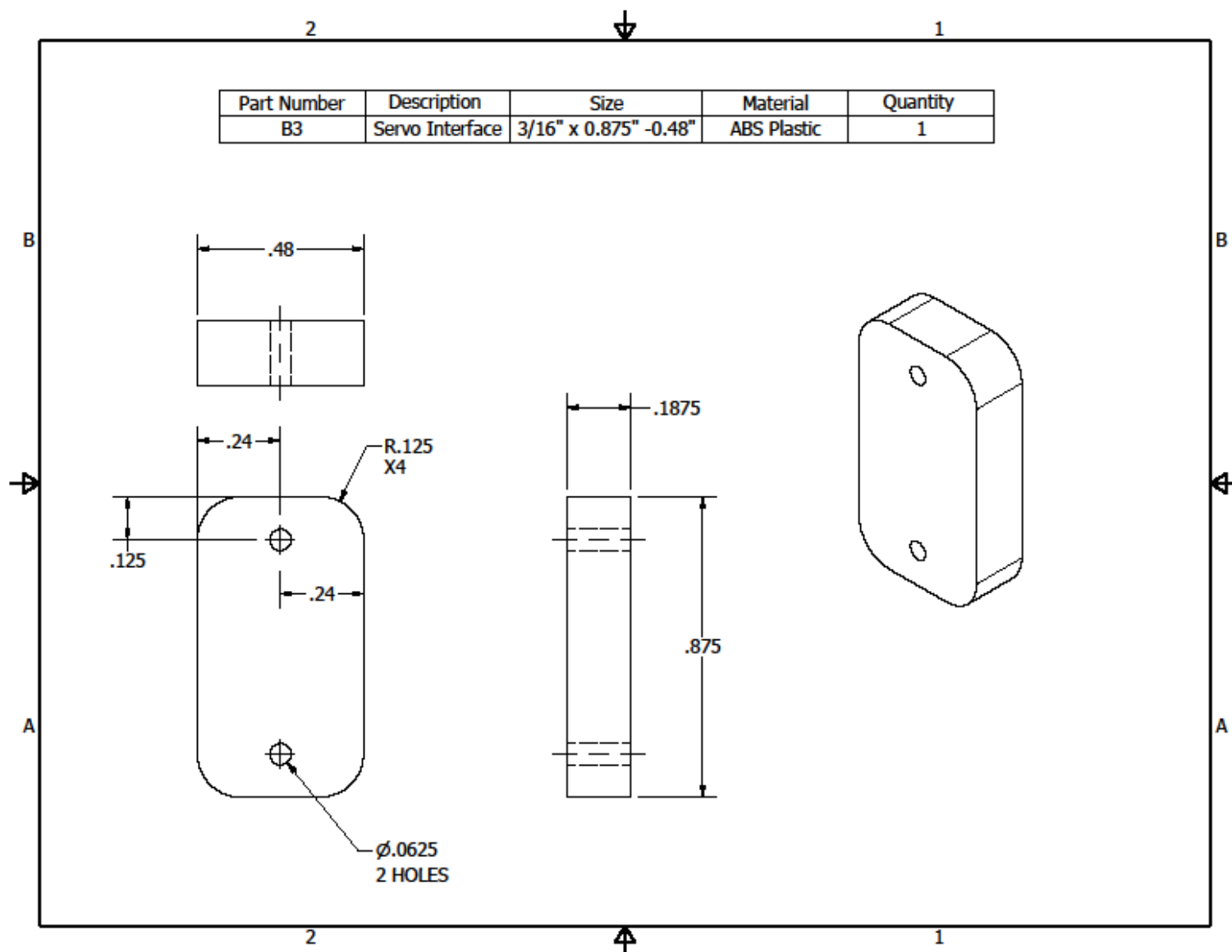

Figure A-18: Servo Interface

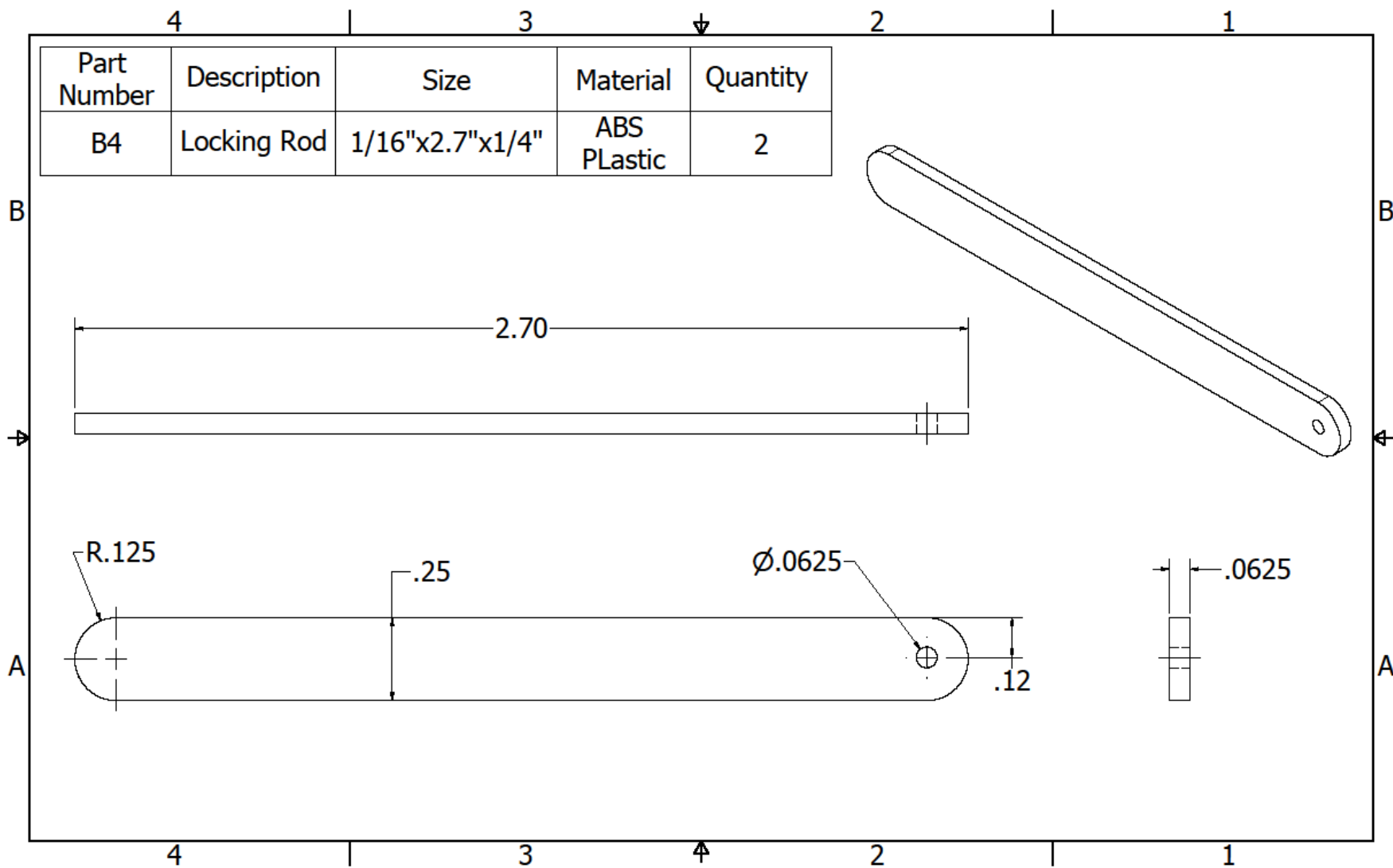

Figure A-19: Locking Rod

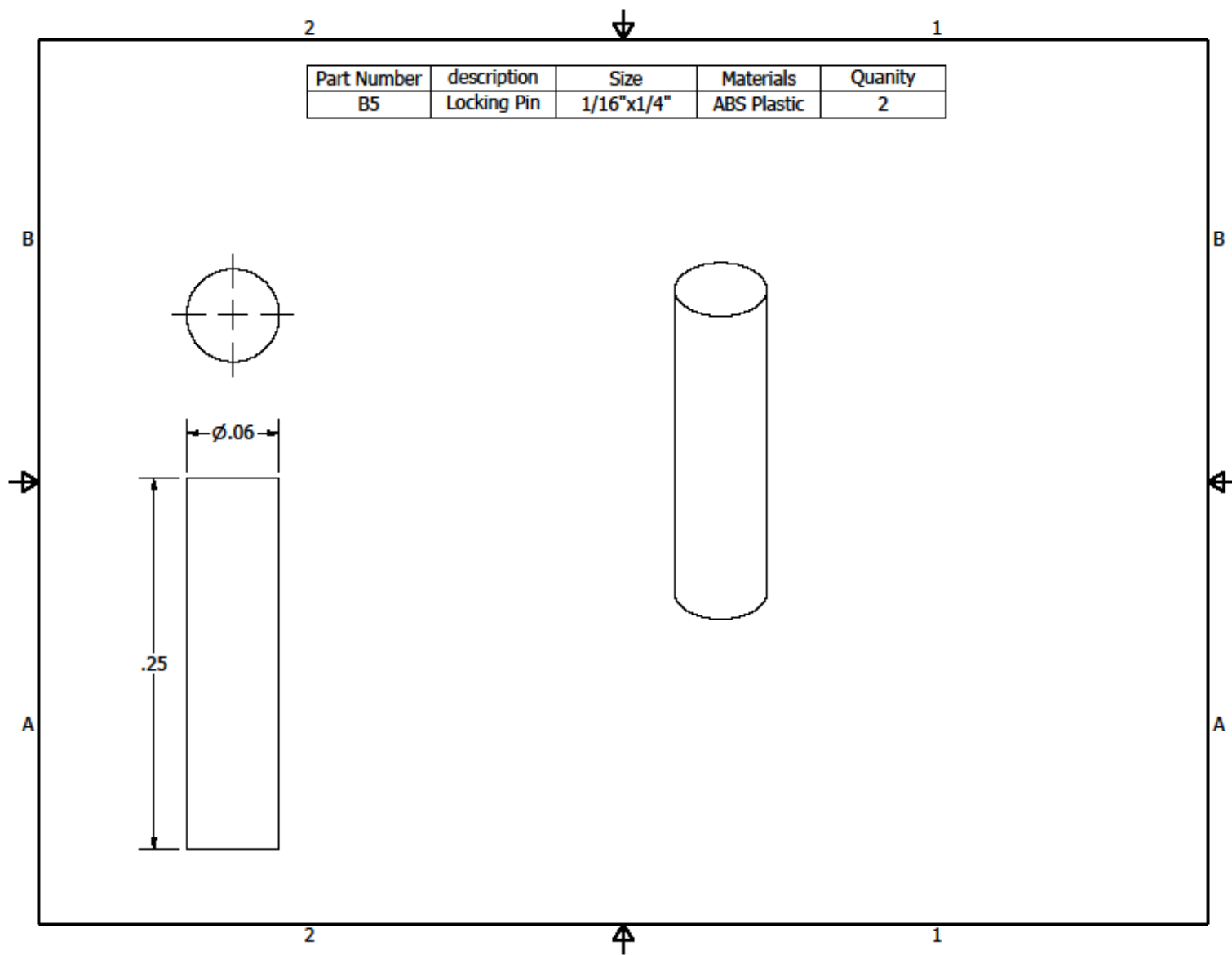

Figure A-20: Locking Pin

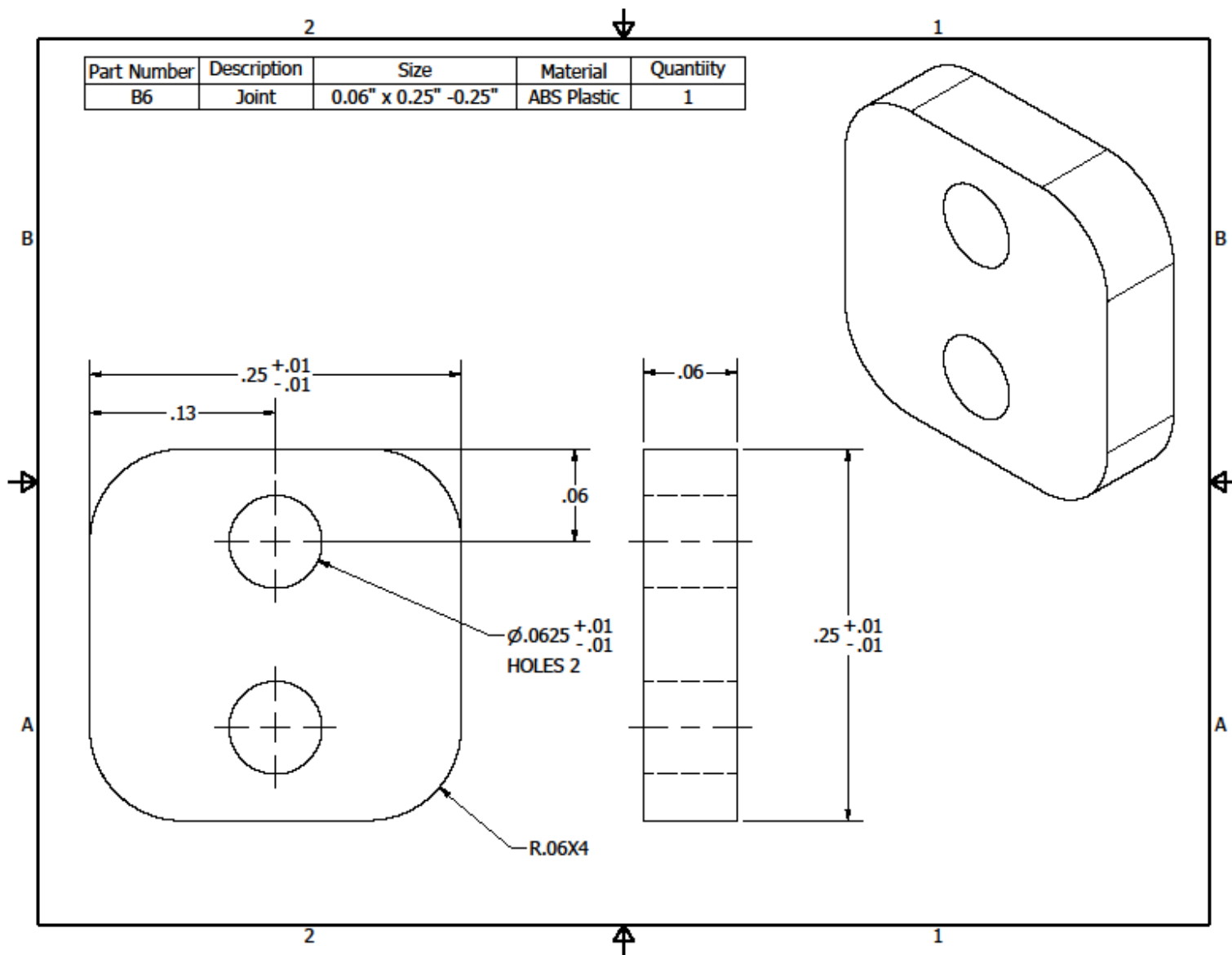

Figure A-21: Joint

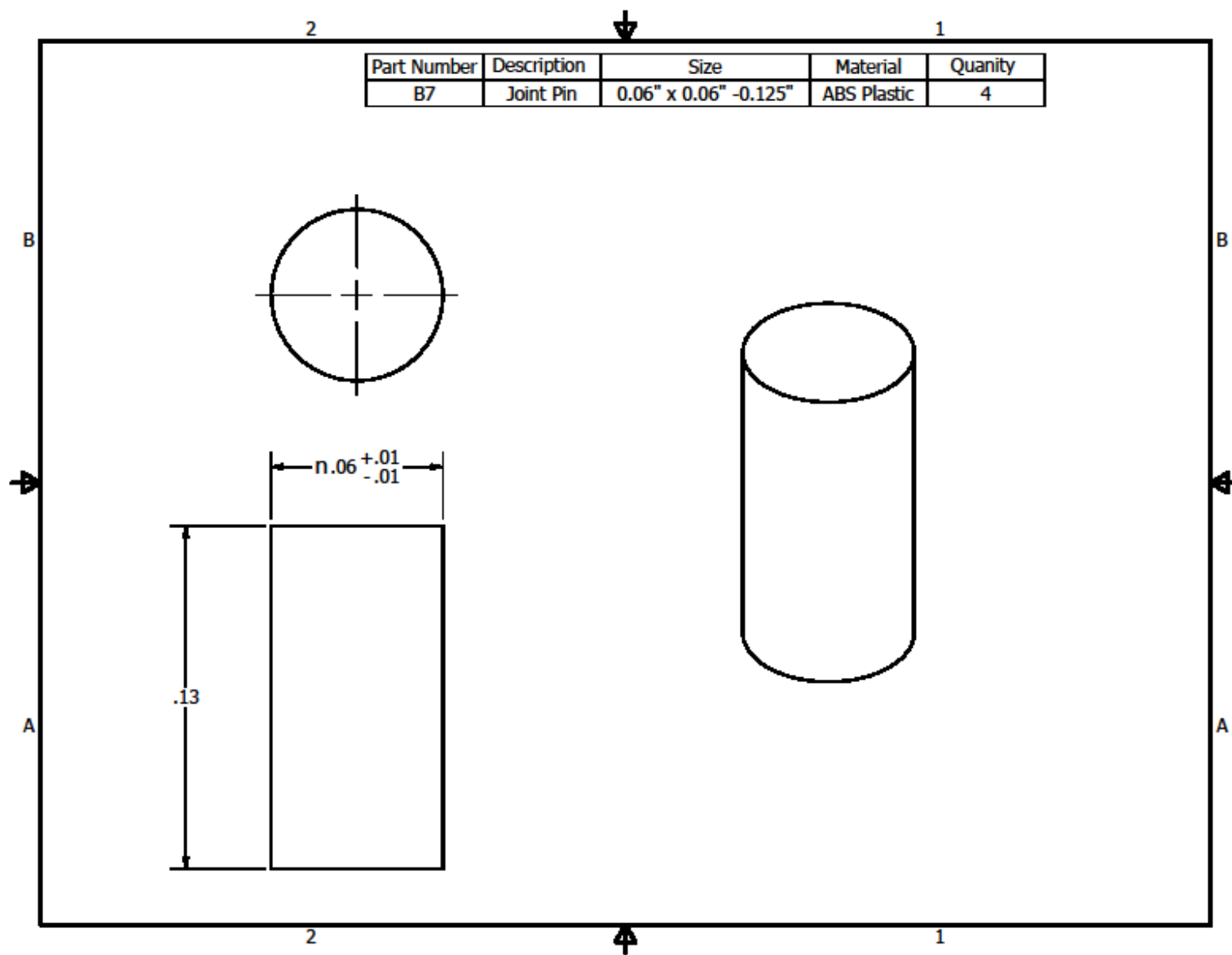

Figure A-22: Joint Pin

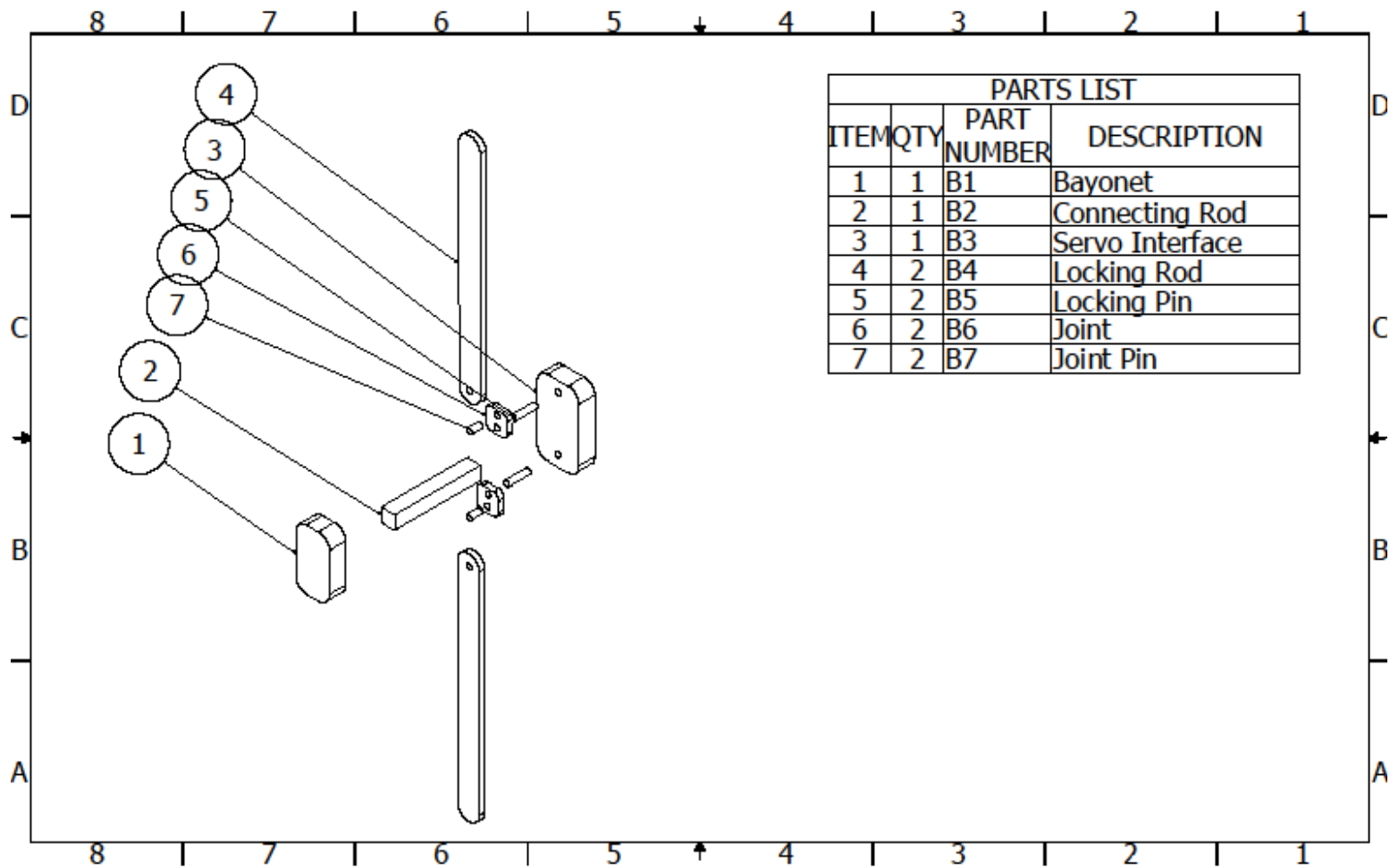

Figure A-23: Bayonet Fitting Assembly

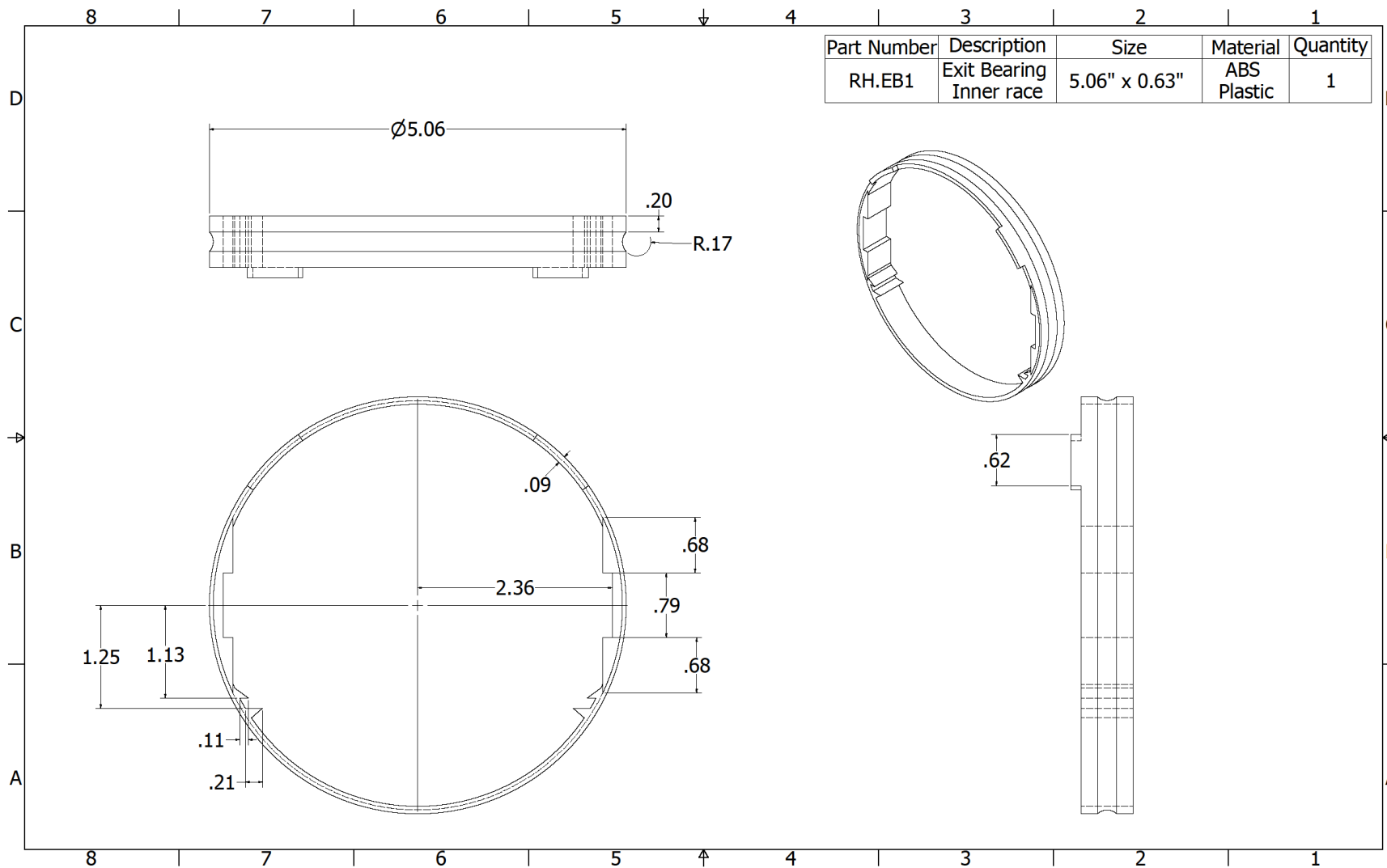

Figure A-24: Exit Bearing Inner Race

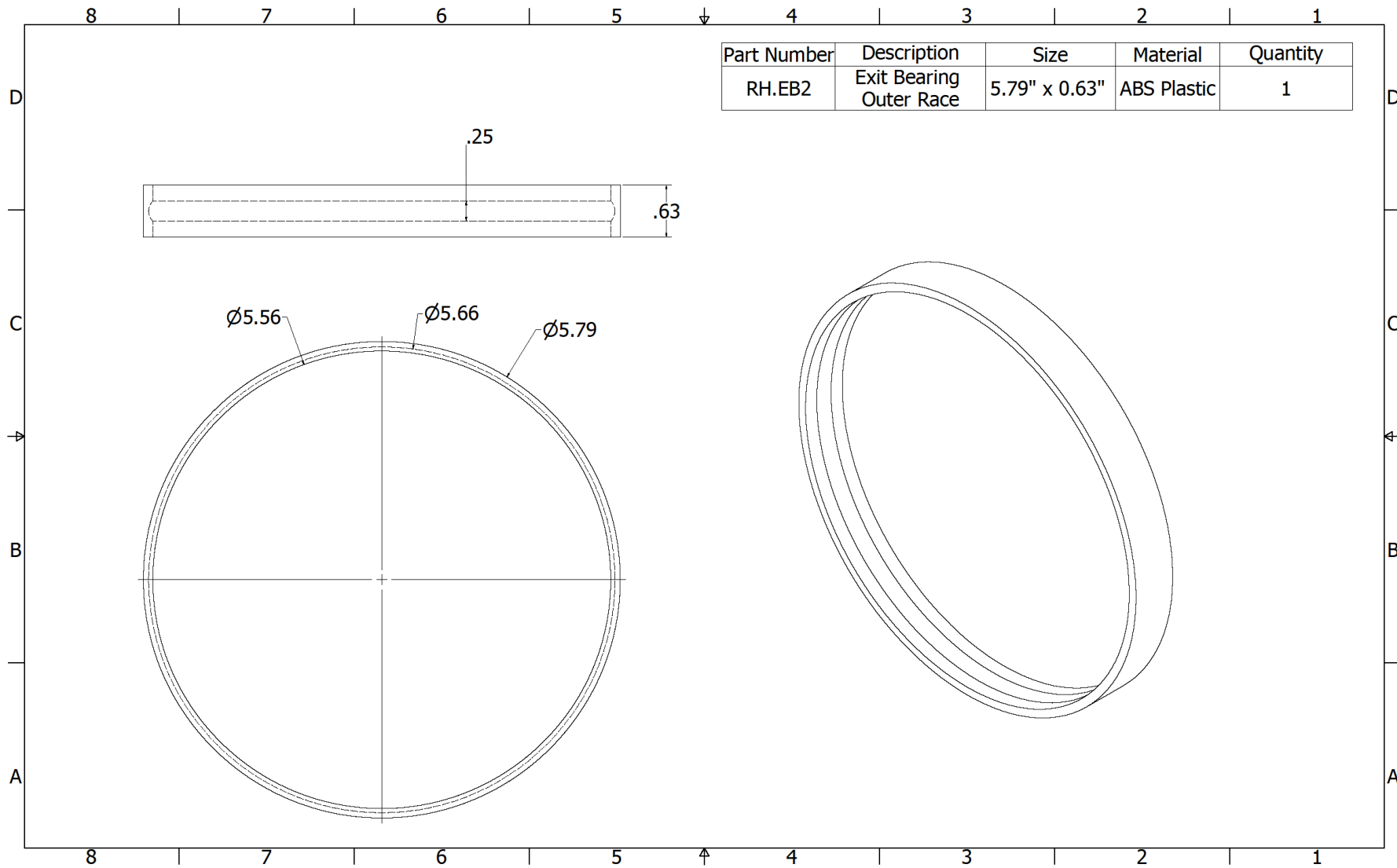

Figure A-25: Exit Bearing Outer Race

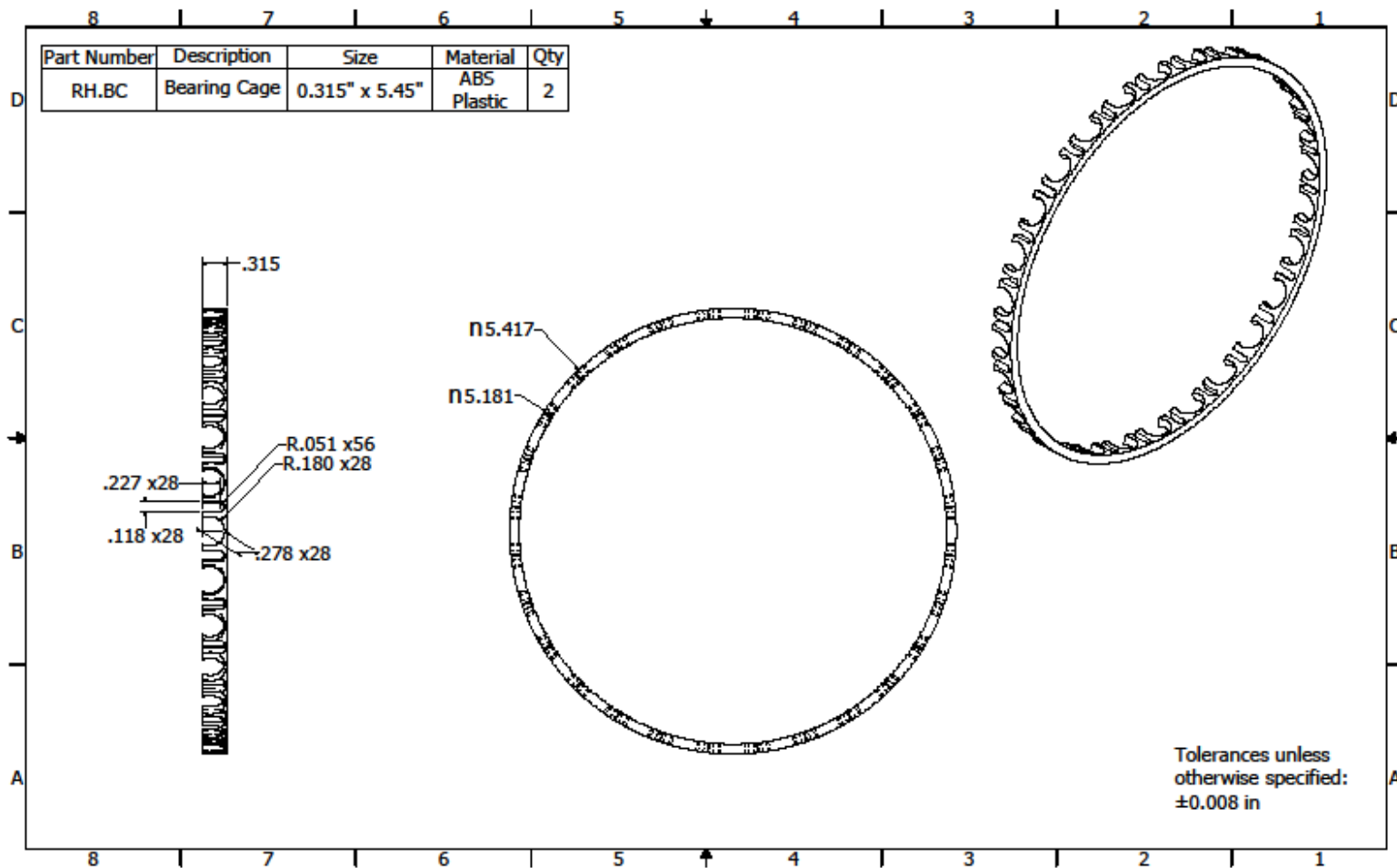

Figure A-26: Bearing Cage

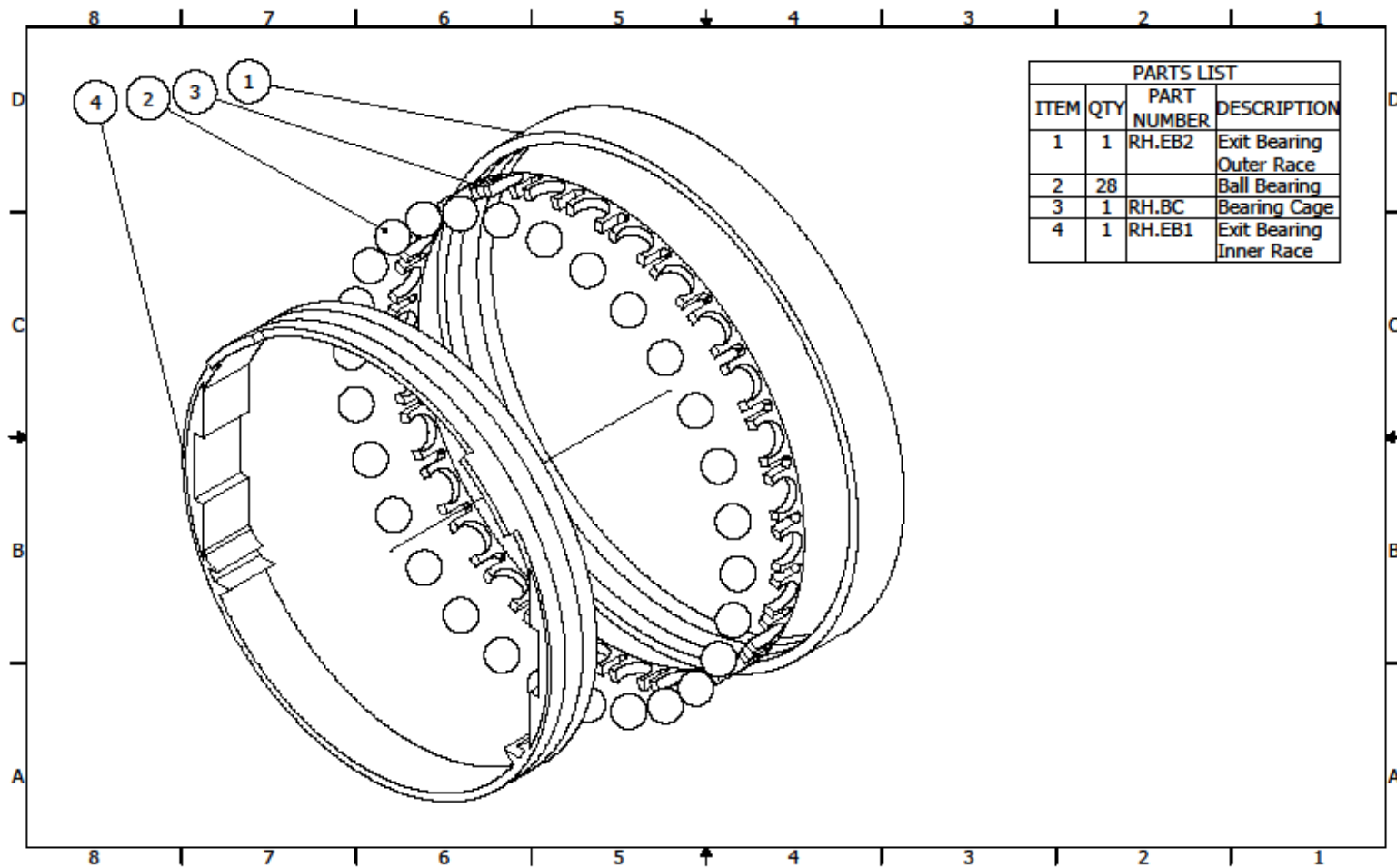

Figure A-27: Exit Bearing Assembly

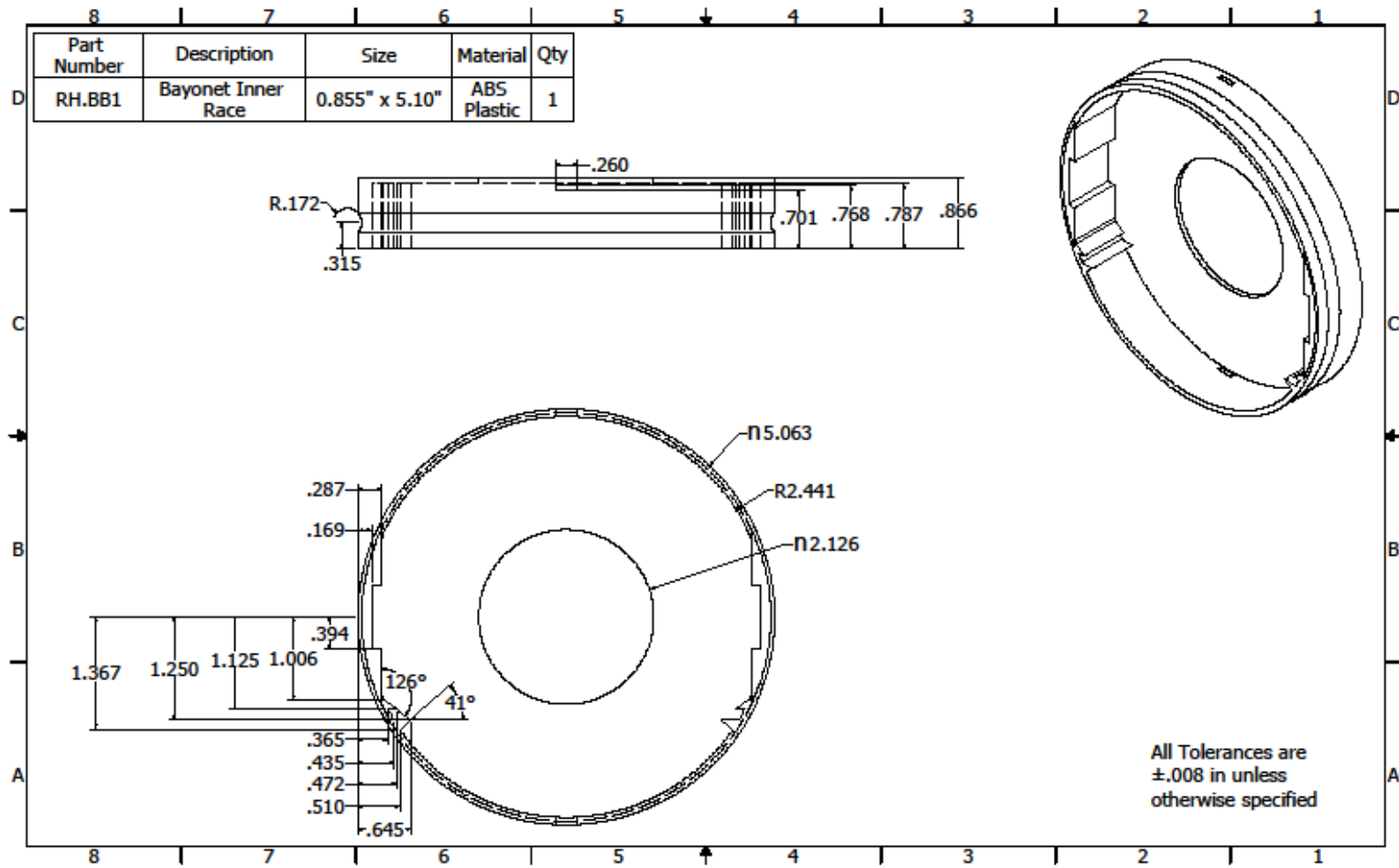

Figure A-28: Bayonet Bearing Inner Race

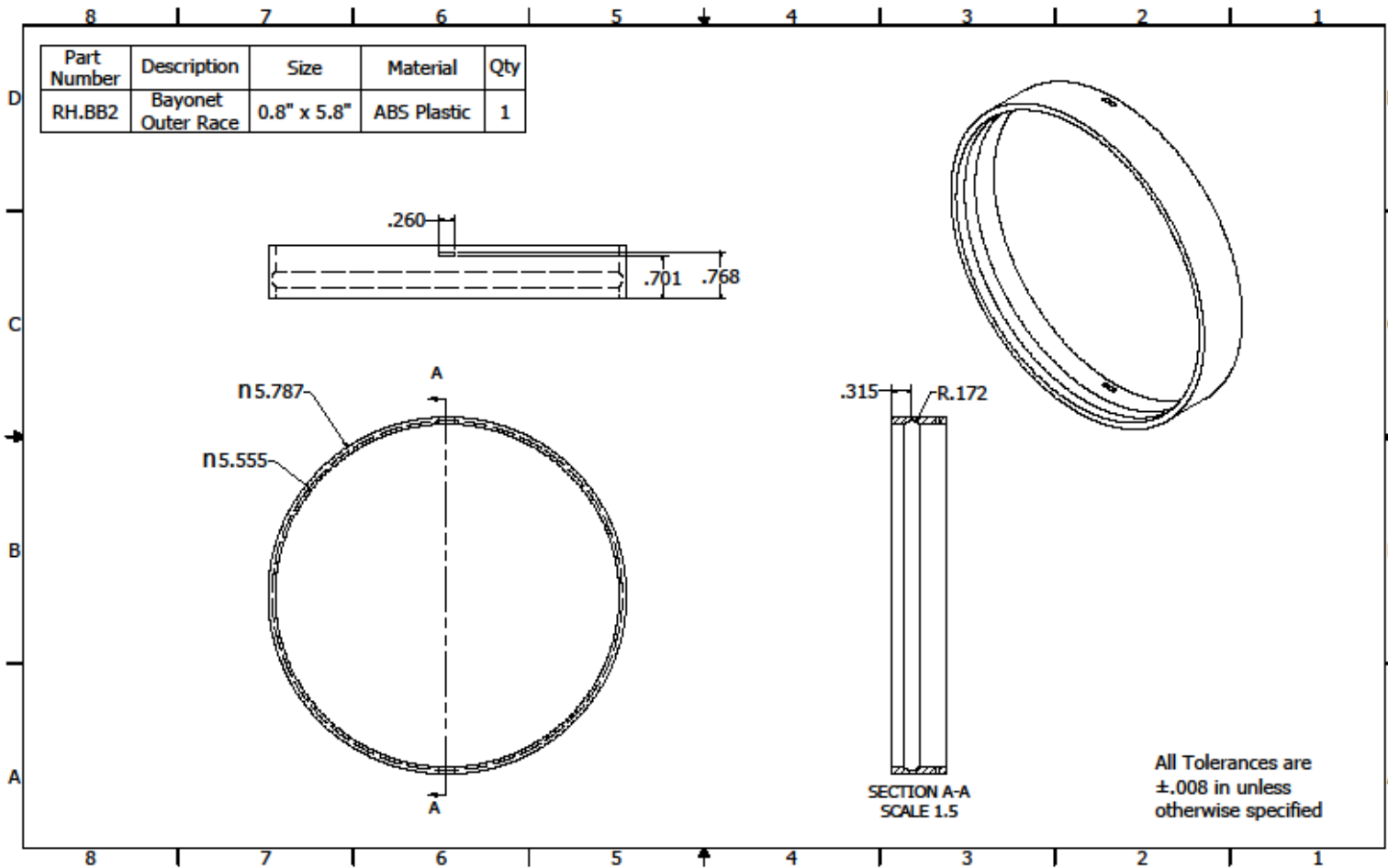

Figure A-29: Bayonet Bearing Outer Race

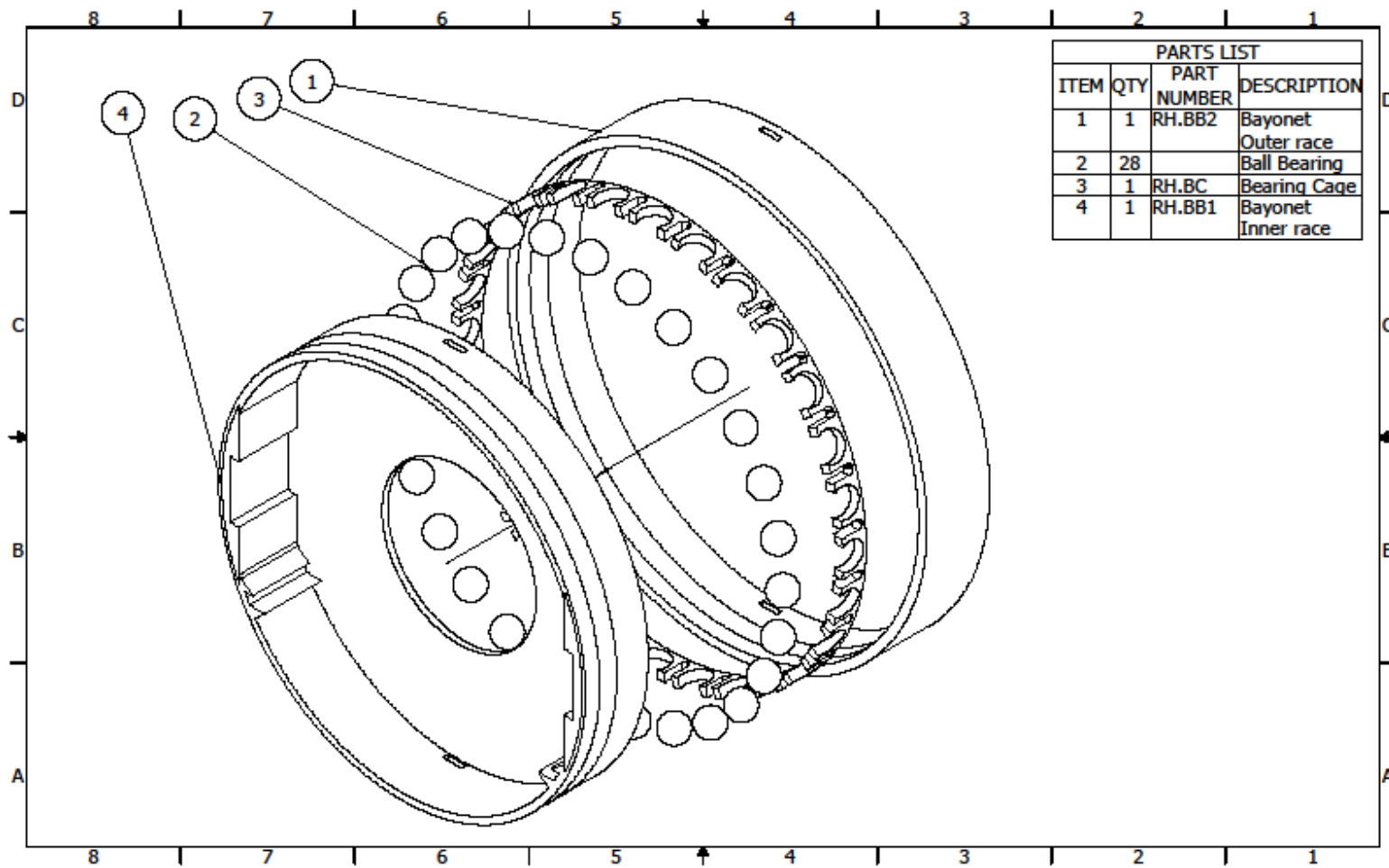

Figure A-30: Bayonet Bearing Assembly

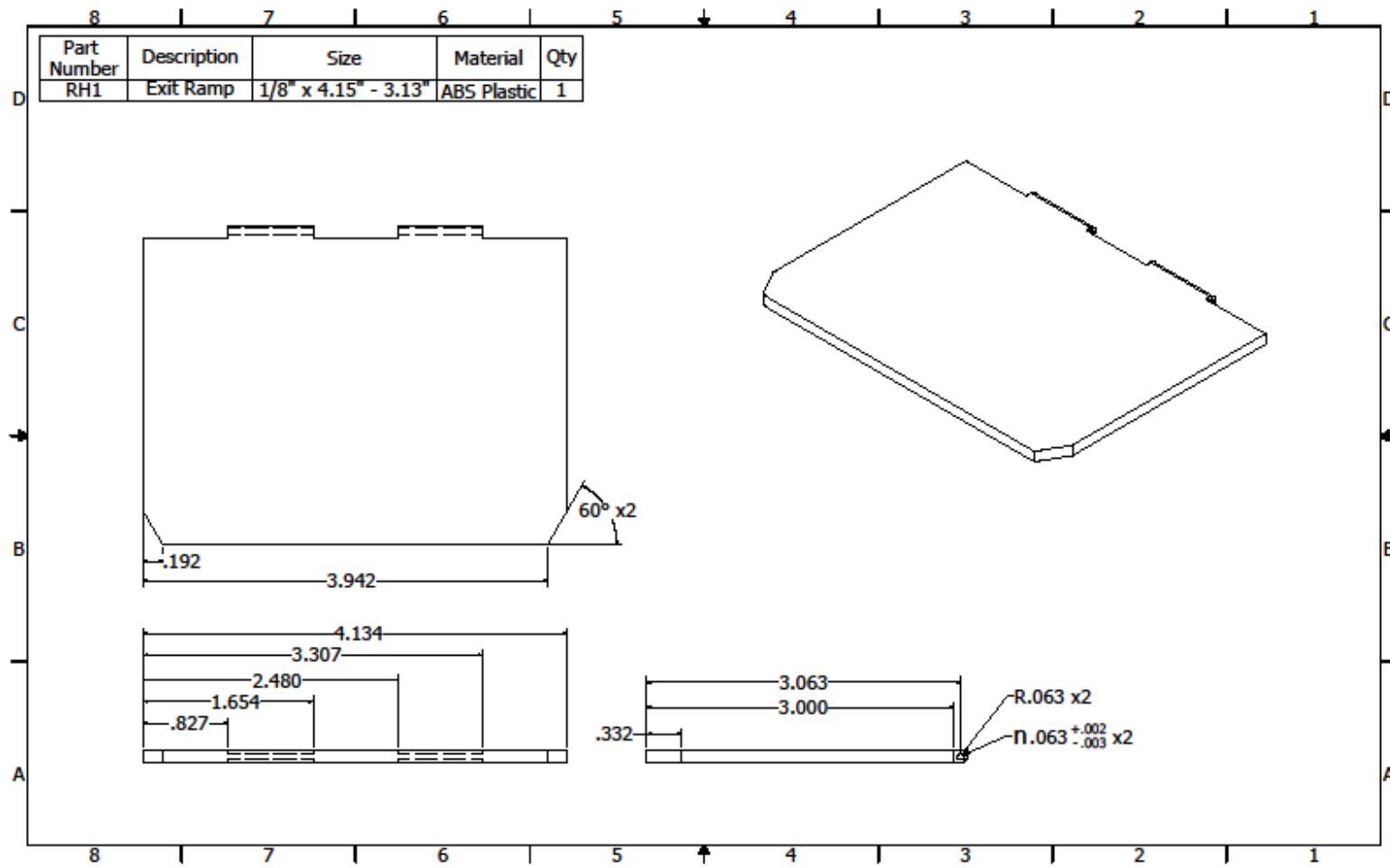

Figure A-31: Exit Ramp

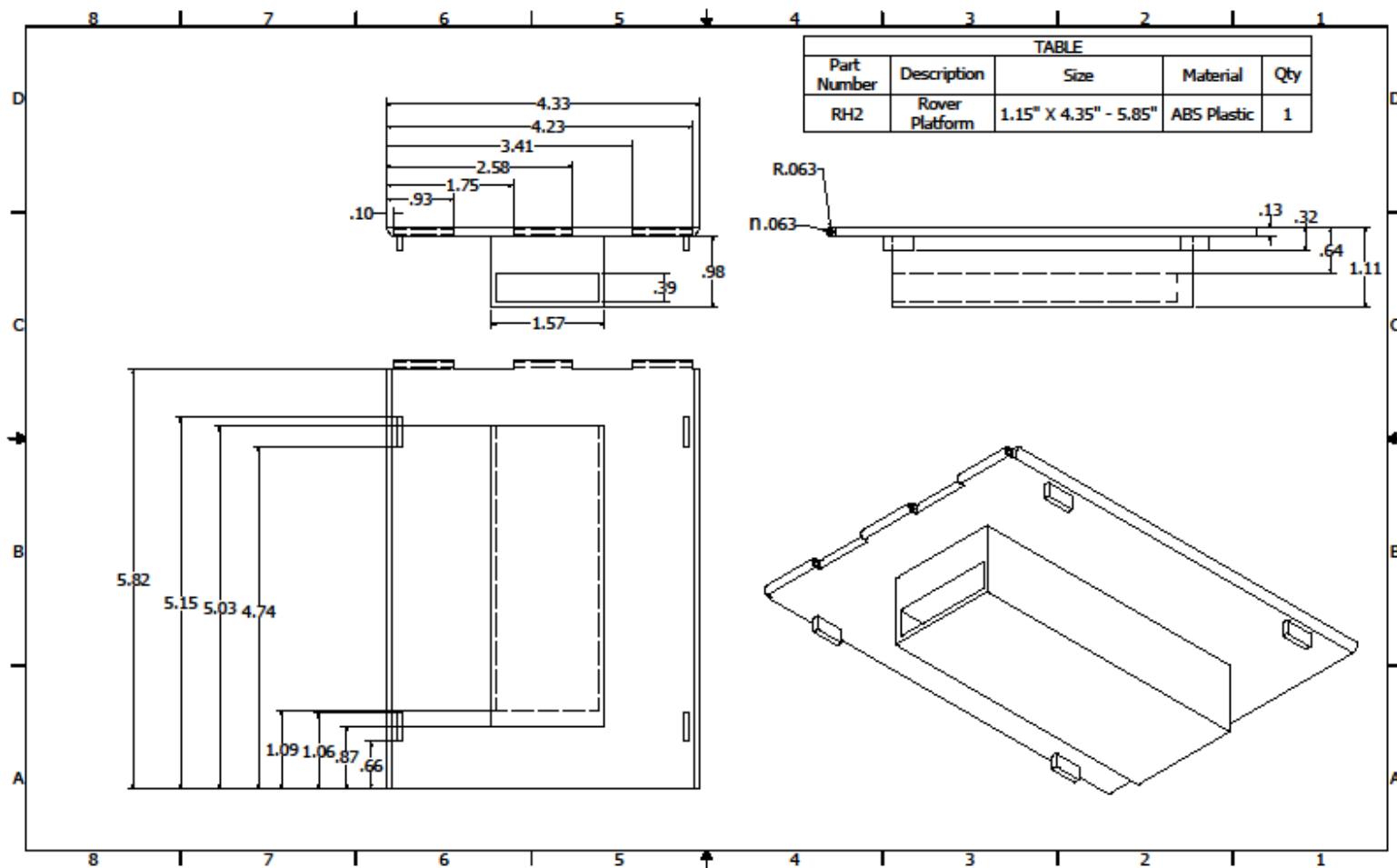

Figure A-32: Rover Platform

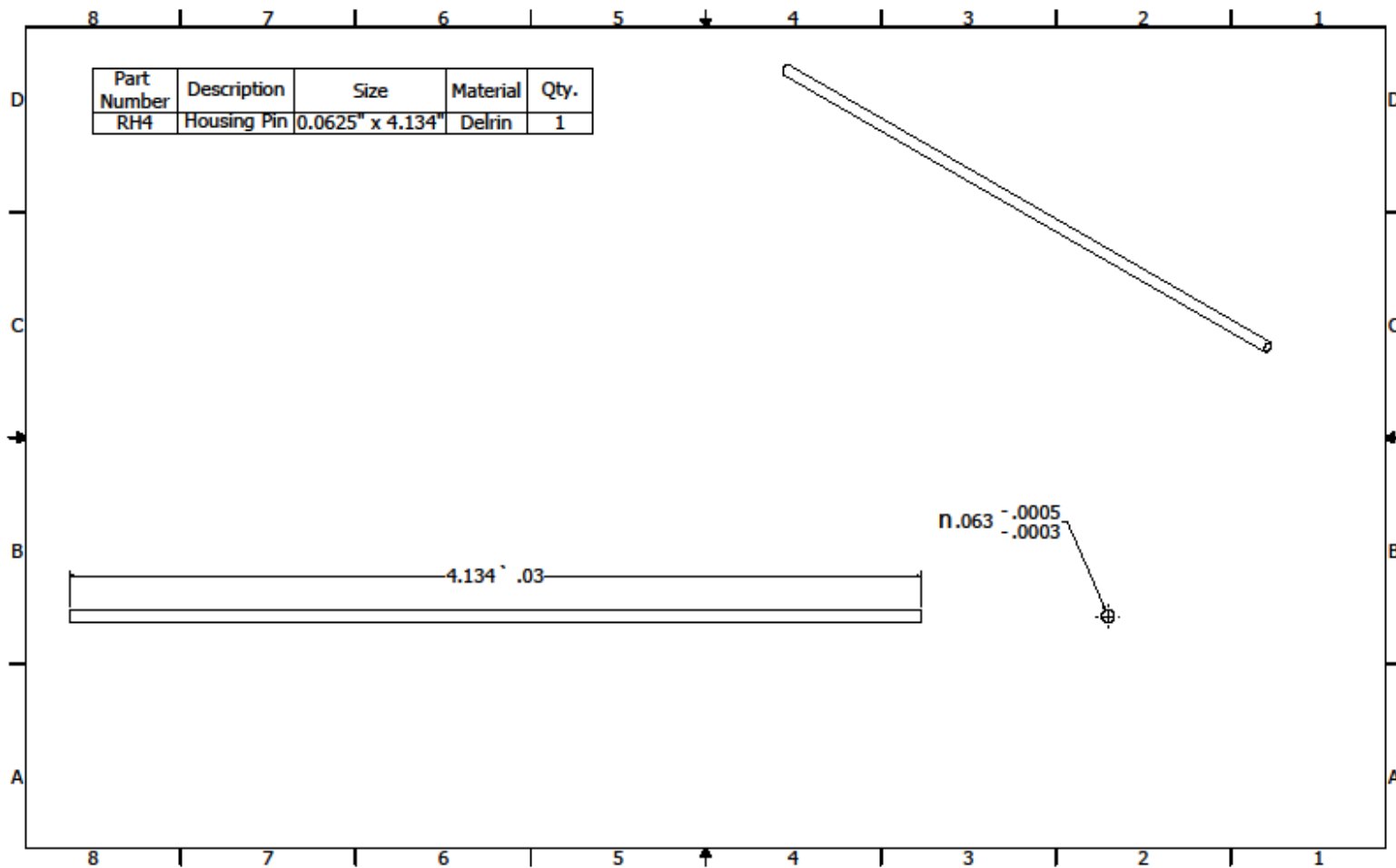

Figure A-33: Housing Pin

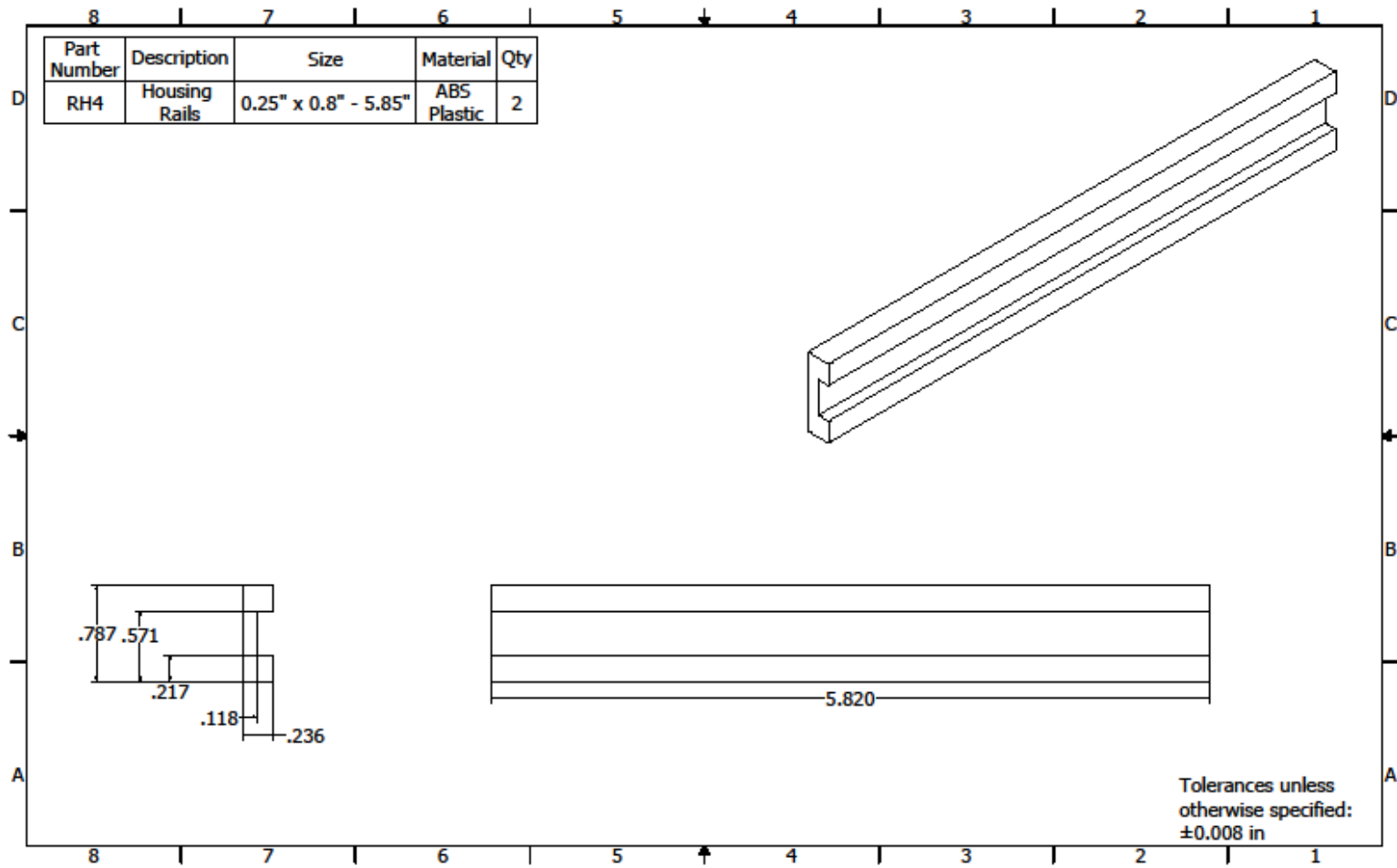

Figure A-34: Housing Rails

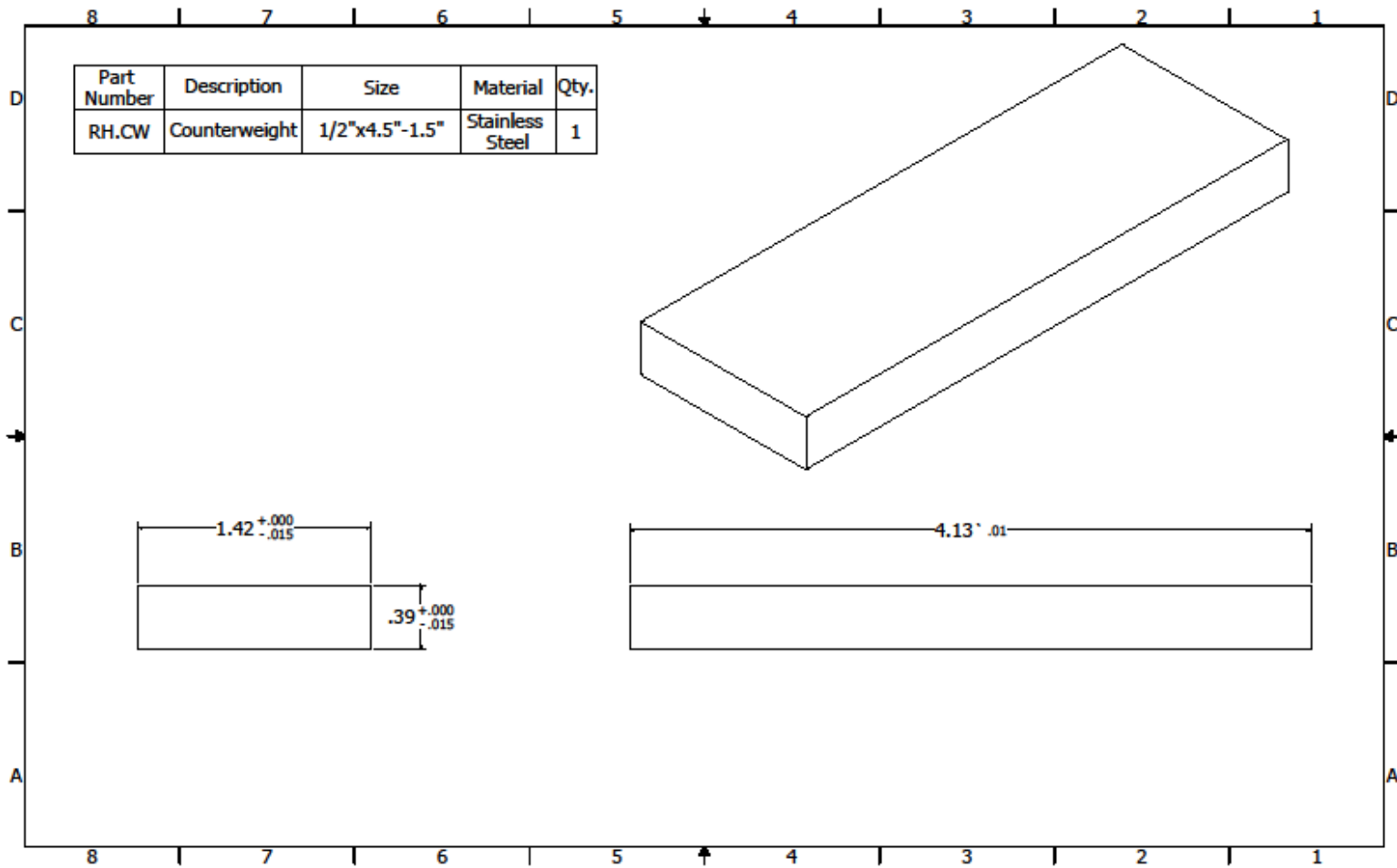

Figure A-35: Counterweight

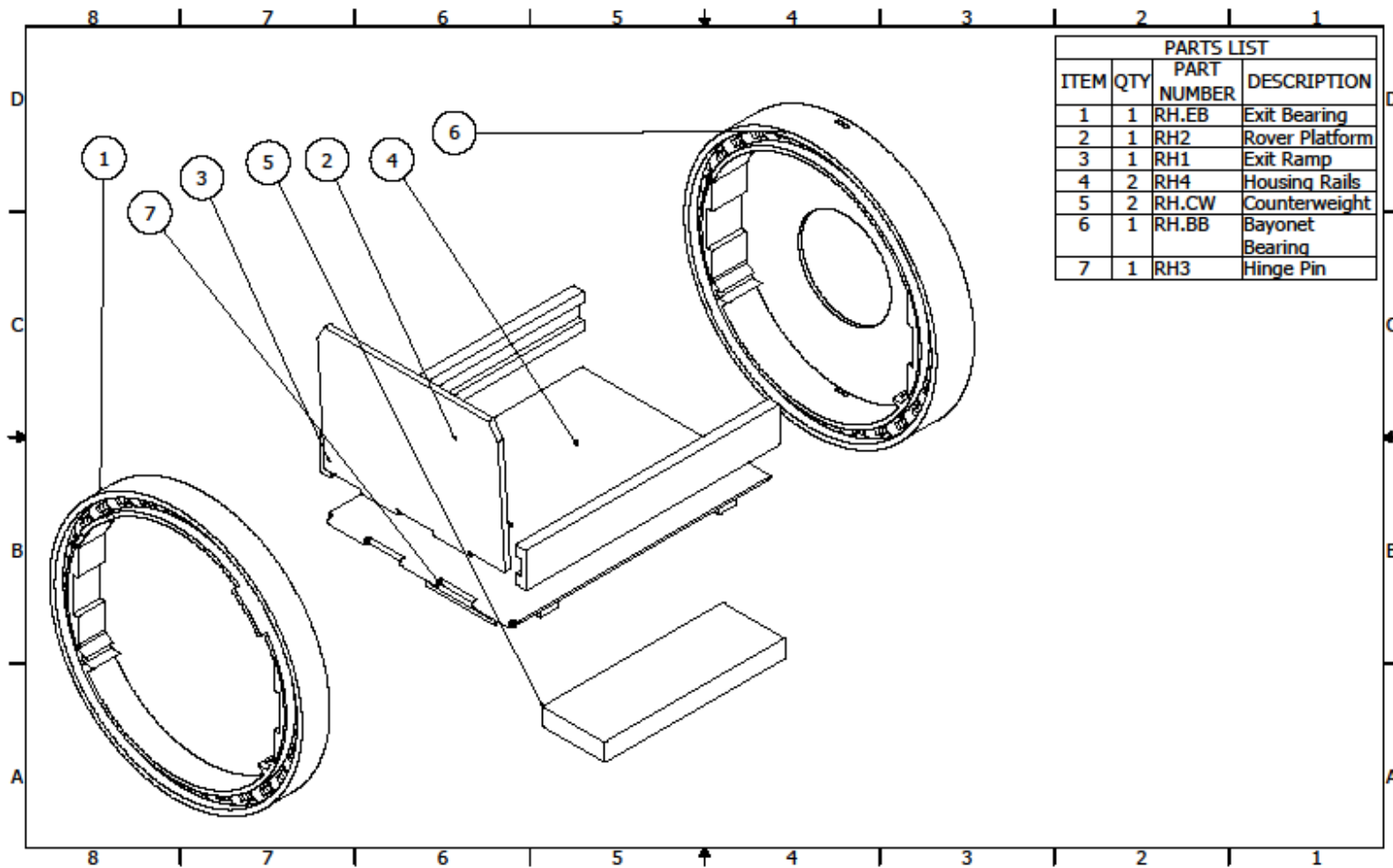

Figure A-36: Rover Housing Assembly

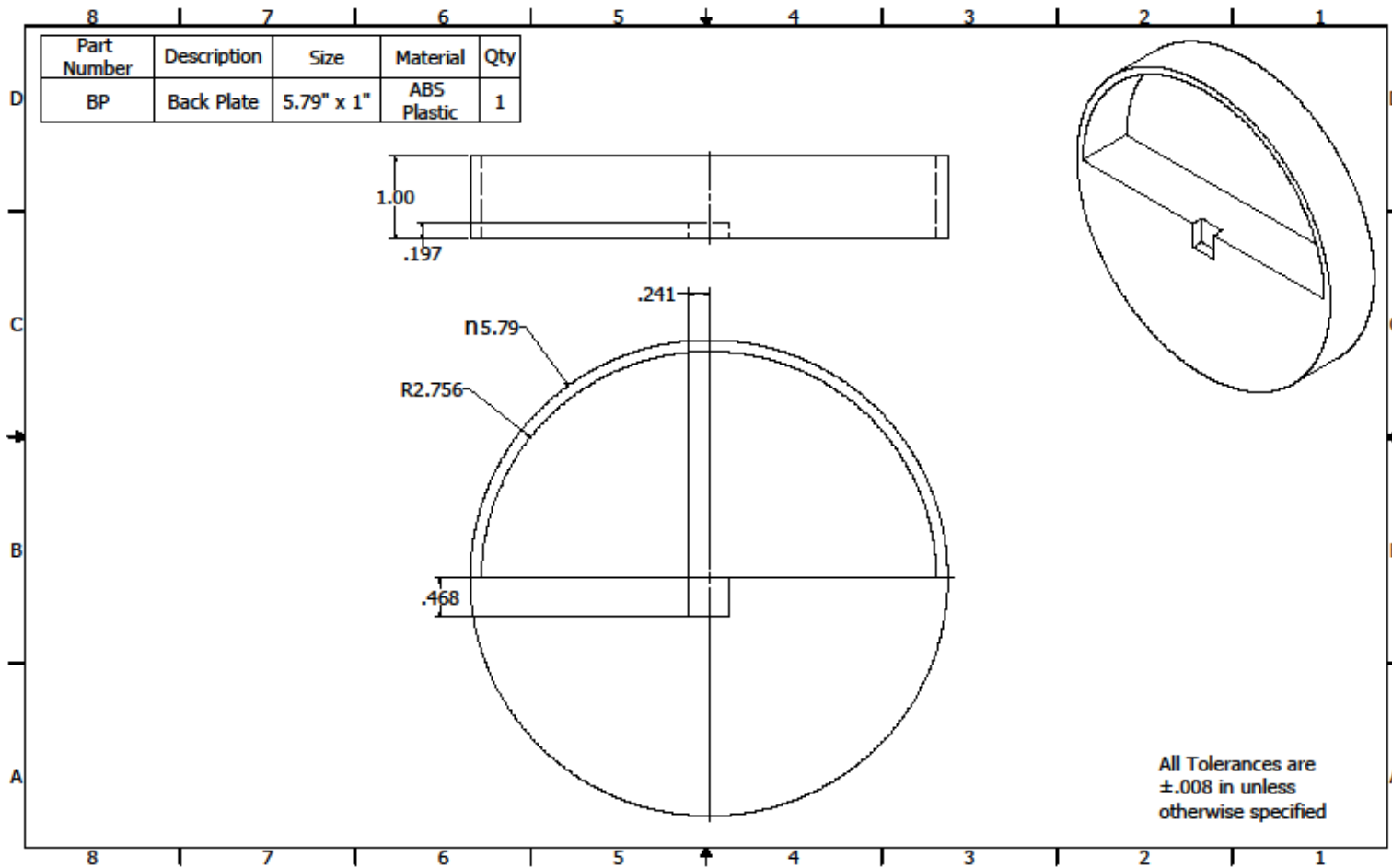

Figure A-37: Housing Back Plate

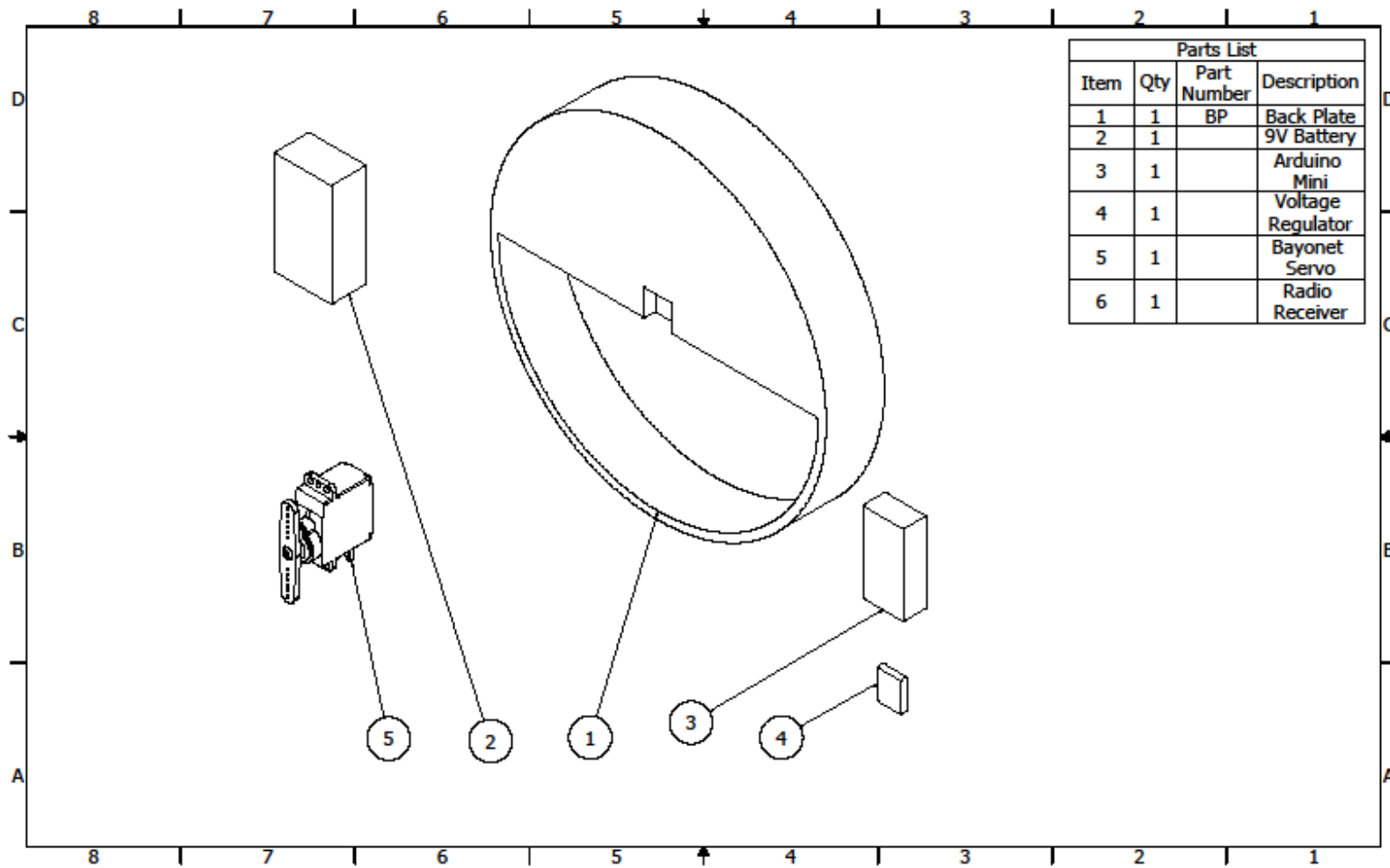

Figure A-38: Rear Payload Assembly

Appendix B – A Guide to Building a Level One Rocket

Constructing a High-Power Rocket

A guide on building the Raider 1



Introduction:

A team of Texas Tech students built the Raider 1, with the supervision and assistance of the safety officer, vehicle team lead, and mentor. The Raider 1 uses an Aerotech H283ST-15A Super Thunder and will be used for the Tripoli high power rocket certification 1 launch for the Vehicle Team Lead. This rocket follows the design of a larger launch vehicle and scaled down geometrically by a 1/3 ratio. Below is a manual that explains the basic construction and assembly of each component.

Nose cone:

The nose cone has been modeled as a solid 1/3 version of the nose cone that will be on the full-scale. While the full-scale version will be two separate sections, the sub scale will not need to be due to the absence of the GPS tracker that is in the upper chamber of the full-scale nose cone. The nose cone was 3D printed with ABS plastic filament, and due to the nature of DFM 3D printing, the surface had to be smoothed to get rid of the layered texture to reduce the. A new process was tested by using sandpaper for both dry and wet sanding on the nose cone, from 200 grit – 1200 grit with steps of approximately 200 grit in between sanding applications to create the smooth surface. Due to the success of this smoothing process, it will be utilized for all external 3D printed plastic parts of high powered rockets built in the future. Pictures were taken of the textures of the ABS layers from before and after the sanding process and can be seen in figure B1.



Fig B1

Motor Retainment:

The motor retainment system for the sub-scale rocket, though similar to the full scale, is not as complex due to the relative decrease of forces that are acting on it. The sub-scale rocket uses centering rings, a 38mm inner tube for an H motor, and a motor retainment ring that is epoxied into the airframe using the same epoxy that is used for the fin fillets. One can consider the encapsulating foam as a factor in this sub-assembly as well. The centering rings were designed to be slightly smaller than the inside diameter of the body tube and have a concentric hole that is slightly larger than the inner tube and to be made out of 2.7mm plywood. The tolerance on the centering rings were chosen to be a Class III medium fit. After designing the centering rings on a CAD software, the design was sent to a CNC wood router was used to cut out the centering rings to the exact dimensions. The CNC router is used many times on this build, and proper setup is critical to get perfect parts, therefore in order to prevent the plywood from slipping, double sided tape was used to hold the sheet on to the cutting table. This can be seen in figure B2:



Fig. B2

Converting the DXF file to a cutting path that the CNC machine can read is something that must be done by exporting a DXF file to a specialized CAM software that is compatible with the respective CNC machine. Figure B3 below shows the CNC router cutting out the centering rings.



Fig. B3

After the centering rings are cut out, final sanding was required to attain the Class III medium fit. This was done using a combination of sandpaper and a cylinder sanding bit on a drill and is shown in figure B4 below.



Fig.B4

After the centering rings are cut and sanded to size, one of the rings is epoxied onto the inner tube. Next, the fins will be added to the airframe and will undergo simultaneous construction with the motor retainment.

Fins:

The fins are made out of the same 2.7mm thick plywood as the bulkheads and retaining rings. The CNC router was used to cut out the shape from a piece of plywood. The design of these fins are scaled down to 1/3 of the full scale, not considering thickness.

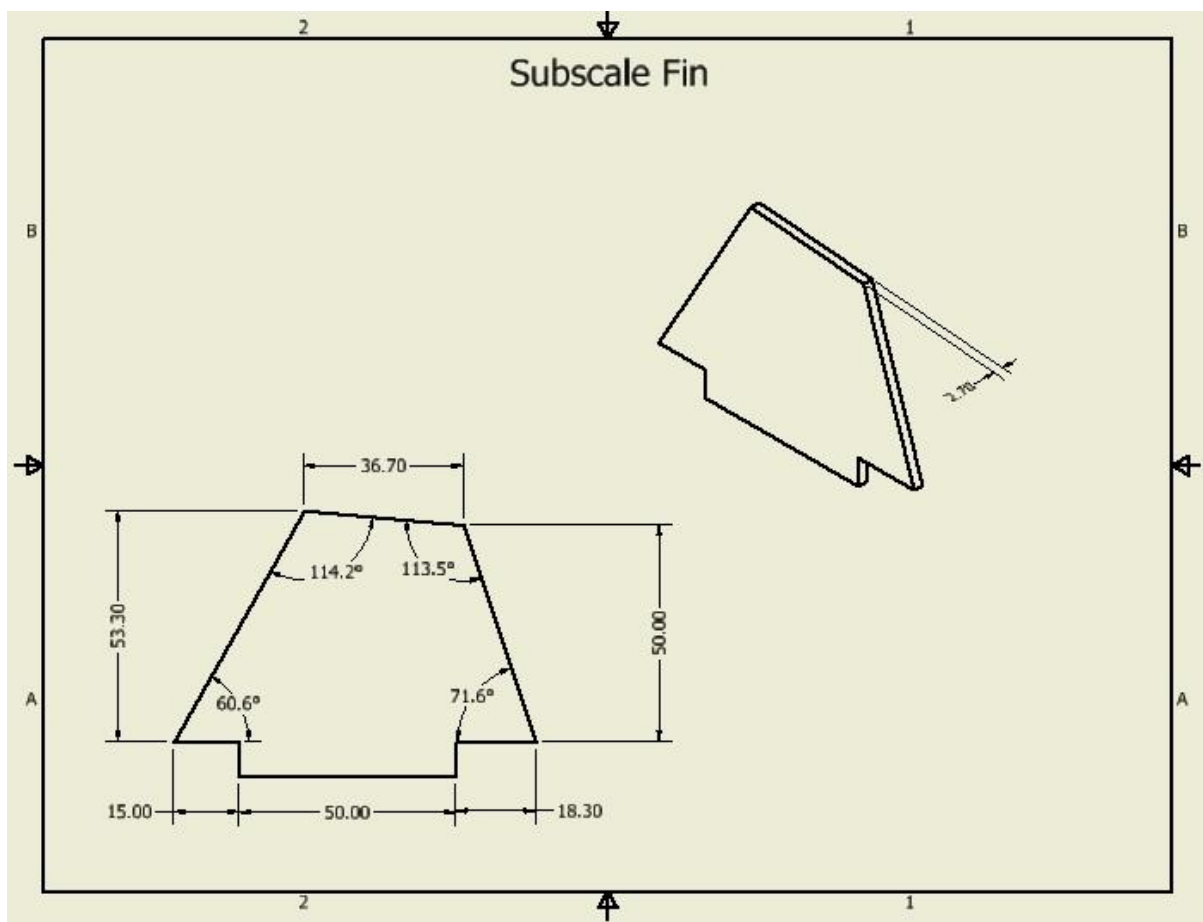

Fig.B5

Using the CNC router saved time and enhanced the precision of the final product. The result after the cuts are wooden fins with the exact same dimensions as the CAD model. Some post work is required to smooth the edges. This can be done by using heavy grit sand paper to de-burr and round the edges. Fin tabs were included, and can be seen in figure B6.



Fig.B6

Custom tooling was created to cut the fin slots. Because the fins must be oriented exactly 90 degrees from each other and equidistant, it was decided that the easiest way to cut the slots was to design and 3D print a jig/template that slides over the end of the airframe and has negative space where the fin tabs will be inserted into the airframe. This technique can be scaled up and used for larger diameter rockets and fins by simply changing the CAD design and printing a new template. This “jig” can be seen taped onto the airframe in figure B7.



Fig.B7

After lines were marked on the airframe for proper fin placement, they were milled out to match the thickness of the fins using a manual end-mill and a woodruff cutting bit. Using an end mill is optional, as a hand held rotary tool such as a Dremel can also be used if there is no access to precision machinery. The mill set up can be seen in figure B8.



Fig. B8

After milling the fin slots, the inner tube from the motor retainment section is then inserted and epoxied into place around the centering ring inside of the airframe. Be sure to leave enough room between the centering rings for the fin tabs. Then the fins are inserted through the slots in

the airframe and with the tab resting on the outside of the motor mount as seen in figure B9, epoxied into place. The fins will then be secured with additional fillets along the outside edges, flush with the airframe and encapsulated from the foam that is used around the motor mount.



Fig.B9

Once the fins are epoxied into place the two-part encapsulating foam is poured into the space between the inner tube and the airframe. Be careful to avoid pouring any foam directly into the inner tube and wipe the surface clean when done. The foam used is variable density and uses drops of water to change the expansion ratio. This is shown in figure B10 below:



Fig. B10

After the encapsulating foam has dried, it has been carved out using a Dremel tool to make room for the rear centering ring and motor retainment ring. These components were epoxied on before beginning the fillets on the fins, and will complete the motor retainment system (see figure B11).



Fig. B11

The fins are now affixed to the airframe by applying $\frac{1}{4}$ inch fillets of RocketPoxy along the root of the fin and the airframe. This enhances the rigidity of the fins and while maintaining an aerodynamic profile. First, the fin was taped off using masking tape to prevent over-epoxying. The 3.2-inch root of each side of the fin required 6grams of mixed epoxy and applied using the curved end of a popsicle to pack it into the edge and create the radius of the fillet. The fillet application setup is shown in figure B12. After the fillets have set for 30 minutes, it is safe to remove the tape, rotate the rocket and apply fillets to the next side. This is to be done four times and then allowed to cure overnight before use.



Fig. B12

Bulkheads:

Because the bulkheads are a major structural component of the rocket, they must be very rigid to withstand the shock of the parachutes tugging against it. Using the same material as the fins, and centering rings, circles were cut to match the inside diameters of the airframe and nose cone to provide a snug fit that will be easy to fillet with epoxy and create a seal. An airtight seal between the bulkheads and the airframe is critical to create a pressure vessel that will force the couplers to slide and shear pins to split and allow for parachute deployment during separation charge ignition. In order to create a stronger bulkhead, two pre-cut wood circles were laminated together using epoxy with a perpendicular grain pattern. This brought the thickness to roughly 1/4in. A hole was then drilled in the center of the bulkhead to mount the hardware that is used for the parachute shock chords. Due to the relatively small size and weight of this rocket, we chose to use 3/16" diameter eye bolts.

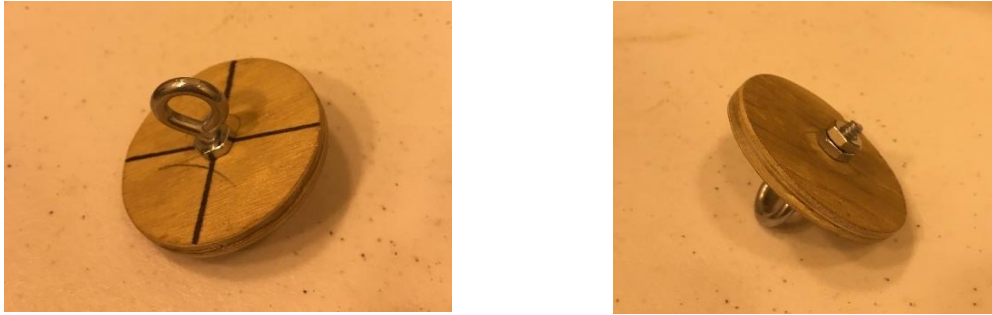

Fig. B13

Airframe:

The airframe of this rocket is made from 2.1 inch phenolic tubing which is lighter, and cheaper than blue tube and fiberglass. However it has spiral seams that stretch down the length of the airframe that were filled with epoxy and sanded smooth for reinforcement and to decrease drag. After the epoxy has set and been sanded, it was cut into lengths that were determined based on the components that will be kept inside. It was initially cut to length using a band saw, however any precision cutting tool can be used for this step. After the pieces were cut to length the fin slots were milled in the aft section (discussed in “Fins”). Other components were added to the rocket body, such as rail guides and threaded inserts for hardware that holds the E-Bay and couplers in position.



Fig. B14

The rail guides used are epoxied onto the outer surface of the airframe, in parallel, on the top and bottom of the aft section, with the bottom guide seated in the valley of two fins. The rail guides can be seen in figures B14 and B11. The threaded inserts were affixed to the inside of a coupler, concentric with 4 holes placed on each quarter of the tube. It is important that the coupler is inserted into the airframe and the holes be drilled through both the airframe and coupler to ensure proper alignment. The threaded inserts can be seen in figure B15.



Fig. B15

E-bay:

The general design our electronics bay was a sled held in place between to G-10 bulkheads with penetrations for ejection charges and parachute connections. The entire electronics bay would be contained within a coupler and inserted into the middle section of our sub scale model.

To construct the electronics bay we first started by making a sled which we could mount the altimeter on along with the battery. We chose to use 1/8th inch thick plywood along with 1/8th inch all thread for the main support material. In order to bond the two parts we used a liberal amount of G5000 which can be seen near the bottom of figure B16:



Fig B16

In order to ensure that we would still be able to fit the electronics bay inside its respective coupler we taped off each side of the plywood making a smooth line down the side and insuring no resistance upon final assembly. To verify this was not a problem we slid it into its coupler to make sure it fit.

When constructing the G-10 bulkheads we again used a CNC router to cut out the two bulkheads. These two bulkheads were slightly different as they needed to have an indent to fit inside the coupler while still being able to sit on top which is shown in figure B17 and figure B18:



Fig. B17



Fig. B18

Next we had to drill holes in order to accommodate the penetrations for our shock cords, ejection charges, and sled. The first penetration we added to the bulkheads was the center hole where which will be utilized to attach the shock cords to the electronics bay. To insure the holes were perfectly centered we used the CNC router to bore these holes. Now to ensure the two holes for the sled were aligned we carefully marked where the sled would need to penetrate the bulkhead then used the center hole to bolt both bulkheads together ensuring they did not move while drilling. The two ejection charge penetrations were slightly easier as they did not have to be so precisely placed on the bulkhead. These were again will drilled with the drill press while the bulkheads were still fastened together. The finished bulkheads can be seen below in figure B19:



Fig. B19

The next step in our build process was to add the hardware to help secure the shock cords and the ejection charges. For the ejection charge penetrations we used 1/16th inch diameter all thread with 2 nuts on either side. We decided to use all thread instead of simply running the wire through the bulkhead to create a more airtight seal to prevent the corrosive gasses released when the black power detonates from getting into the electronics bay. The two nuts on either side are used as an electrical connection clamping lead wires in place. Second we added a 3/16th inch eyebolt to secure the shock cords to the electronics bay. Again this will be secured by 2 nuts in either side of the bulkhead to lock the eyebolt in place. The finished assembly can be seen below in figure B20:

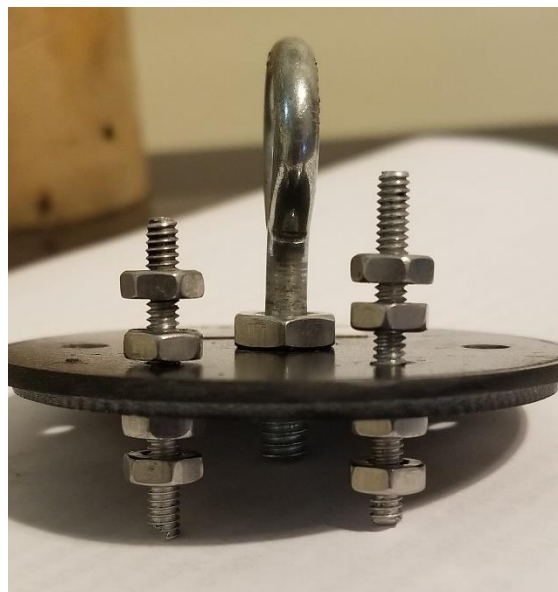

Fig. B20

Moving forward we worked on building the sled by attaching the altimeter and battery to the plywood sled. We first worked on placement of the two main components by laying them out and marking the plywood sheet with a sharpie assuring that the altimeter and battery mechanical connections did not interfere. With the altimeter requiring space off the back of the circuit board we had to countersink screws through the back of the plywood sheet in order to not obstruct the battery when we placed it on the sled. We then used a lock nut on the exposed threads to insure enough space between the pressure sensor on the altimeter and the sled. Finally we bolted the altimeter to the sled to secure it in place during flight. For the battery we drilled holes large enough for two 20 gauge wires and a medium sized zip tie. The zip tie was run underneath the altimeter and between the two terminals of the 9 volt battery and tightened to fasten the battery to the board. To enable the rocket to be activated on the launch pad we added a flip switch to the sled perpendicular to the direction of launch to help ensure the altimeter does not turn off during launch. The battery was then connected to the switch where heat shrink was used to ensure that the altimeter was not damaged and can be seen in figure B21:



Fig. B21

The final aspect of construction was to wire the electronics bay together and connect the ejection charge penetrations. We used a simple 9 volt connector attached to the wired directly into the altimeter where the black wire goes into the terminal most closely marked negative. The switch is then directly wired into the altimeter as specified by the altimeter. The two ejection charge leads were then connected to both bulkheads and labeled as either drogue or main. The wiring diagram in figure B21 is shown below:

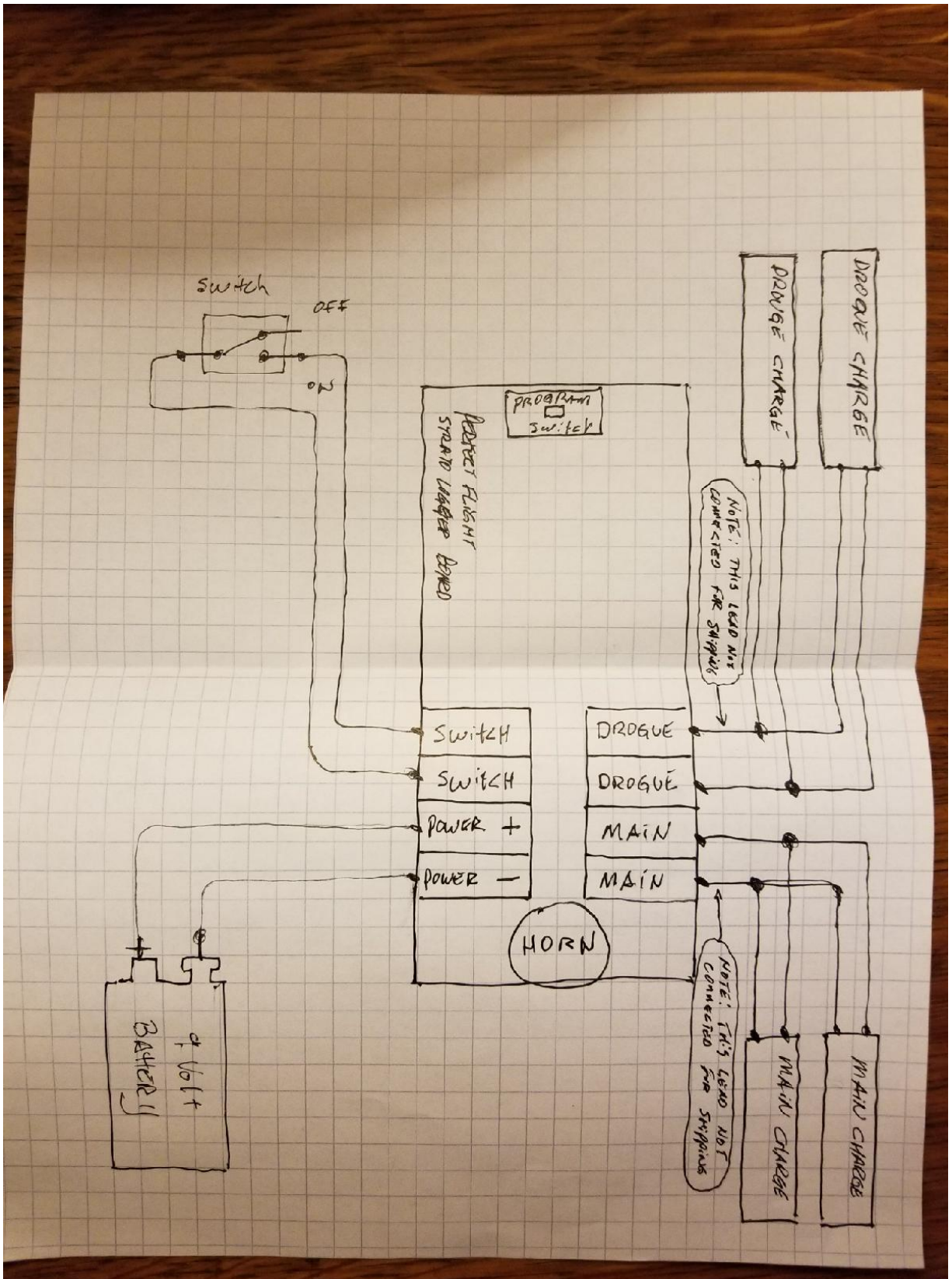

Fig. B21

With all the parts on the sled connected we slid the supporting bolts through the bulkhead and secured it with a series of nuts on either side making sure to lock the side of the main parachute in place and secure that bulkhead to the sled. We then took the electronics bay and put it in its respective coupler and secured the other bulkhead fully containing the electronics bay within its coupler housing. The finished electronics bay can be seen in figure B22:



Fig. B22

The final step of construction the electronics bay was to make it possible to turn on the altimeter from the outside of the rocket without taking it apart. To do this we carefully aligned a hole in the coupler where a small tool could reach in and flip the switch to turn on the altimeter. To ensure we had the orientation of this pin hole correct we drilled a guide hole that went through both the coupler and the airframe. This would help make sure we slid the electronics bay into the correct position. The pin hole we used to turn on the altimeter would also act as the pressure hole that would allow the altimeter to correctly measure the altitude of the rocket upon its decent.

Next we had to make the ejection charges which was done under close supervision from our mentor. The amount of black powder used for the ejection charge was again done by our mentor and came out to be .5 grams for both the drogue and main parachute deployment. To house the black powder we used .5 mL centrifuge tubes after drilling out a hole in the bottom that we could slide an electric match into. We then secured the electric match with electrical tape before packin the black powder in and filling with leftover insulation to help keep the black powder on the electric match.

With the electronics bay and ejection charges finished we moved on to attaching the shock cords to the airframe and to the electronics bay. Seeing how the shock cords need to be attached directly to the bulkheads the bulkheads receded into the air frame had to be tied before the bulk head was secured to the airframe. To attach the elastic shock cord to the bulkhead we utilized an improved clench knot before setting the bulkheads in the airframe and epoxying them in place; this can be seen in figure B23:

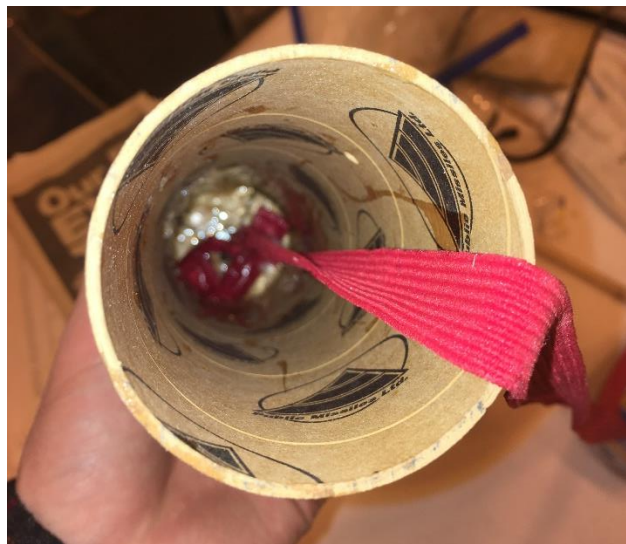

Fig. B23

To attach the shock cord to the electronics bay we needed to make sure that the elastic cord was protected from the detonation of the ejection charges. To make sure that the elastic shock cords were not damaged we had to attach Kevlar leaders to the shock cords and to do this we used a set of loops after tying together two separate bowline knots. We then used another bowline know to secure the Kevlar leader directly to the eyebolt coming out of the electronics bay.

Attaching the parachutes was done at the splice between the elastic shock cords and the Kevlar leader. The first step was to take the parachute and loop it through one of the bowline loops in the fashion show in figure B24:

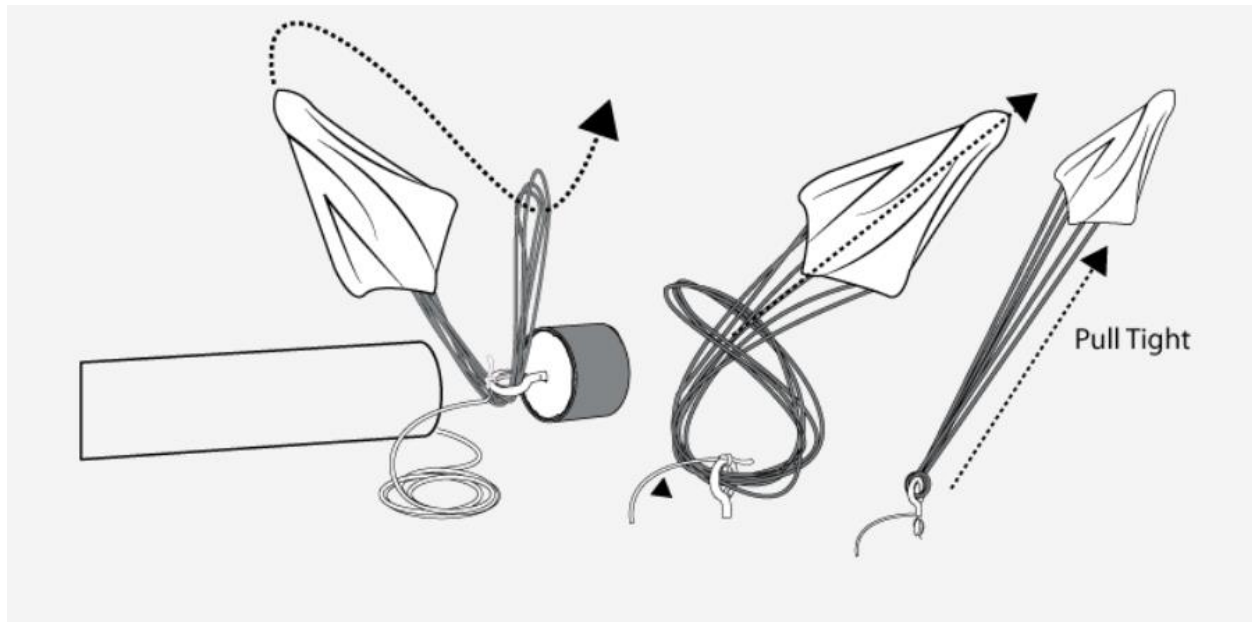

Fig. B24 (ApogeeRocket.com)

When connecting the parachute we had to add a fire blanket to help protect the parachute from the ejection charge blast. This fire blanket will also help protect the shock cord as most of the charge will be contained on the side with the Kevlar leader. The next step was to pack the parachute into the body of the rocket. This was done by folding the parachute up and taking the cords and wrapping them around the parachute before tightly rolling them in the fire blanket. The elastic shock cord was then pushed into the body of the rocket followed by the parachute itself. Finally all the section were put together and ready for launch. Connection between different sections was made with either screws if we wanted a secure connection or a snug fit if we were looking for separation at that section.

Arming and launch precautions:

After all of the components of the high-powered rocket have been created, and ground testing has been completed and passed inspection, the rocket must be assembled and armed on the launch pad. All components are to be inserted into the airframe in its respective orientation and checked for proper fitment. If anything, out of the ordinary is noticed at this stage, it is important that extra inspection takes place to ensure no part fails during launch. Once the rocket is assembled, the motor was inserted into the mount and held in place by the retaining ring. Only when the rocket has been loaded on the launch pad and by a certified high-powered rocket personnel, or under their

supervision should the igniter be inserted into the motor. When inserting the electric igniter take caution to make sure leads are disconnected from the power source and that the igniter is pushed all the way up the length of the fuel grain. During time of launch be sure that the Tripoli and/or NAR safety code is followed, and that all personnel and flammable materials are a safe distance away (see figure B25).

Minimum spectator and Participant Safe Distance Standoffs

Total Installed Impulse, N-s		Motor type	Non-Complex		Complex	
			feet	meters	feet	meters
0.01 to	160	High Power G or smaller	100	30	200	61
160.01	320	H	100	30	200	61
320.01	640	I	100	30	200	61
640.01	1280	J	100	30	200	61
1,280.01 to	2,560	K	200	61	300	91
2,560.01 to	5,120	L	300	92	500	152
5,120.01 to	10,240	M	500	153	1,000	305
10,240.01 to	20,480	N	1,000	305	1,500	457
20,480.01 to	40,960	O	1,500	457	2,000	610

Fig. B25

Appendix C – Reese Technology Center Safety Protocol

RAIDER AEROSPACE SOCIETY REESE TECHNOLOGY CENTER SAFETY PROTOCOL

**The following safety procedures are posted on site frequently as a constant reminder.*

Document Disclosure: This document has been drafted per request of Texas Tech professor, Dr. Gale, in order to appropriately ensure efficiency and safety during the use of this facility.

Tool Disclosure: For specific procedures and regulations, refer to the RoboRaider's Safety Exam:

https://docs.google.com/forms/d/e/1FAIpQLSep1fB0_4bH5-M5h1R-F5xtqwybu_13TJ_1IAHWV1XxpgKnpQ/viewform

**Equipment is used at your own risk and neither the Raider Aerospace Society nor Reese Technology Center accepts any responsibility*

Members of R.A.S. will adhere to the following:

4.2.1 Behavior and Conduct:

- Horseplay or aggressive actions towards any and all persons at the facility will not be tolerated
- The consumption, possession, and the presence of alcohol will not be tolerated on the facility property
- Members will be limited to a maximum of two guests to avoid overcrowding
- All food and drinks must be kept out of construction zones
- Access to equipment other than that owned by R.A.S. must be approved by a credible representative of ownership
- Members should NEVER run inside of the workspace building
- NEVER use equipment you are not familiar with and haven't been introduced to by an authorized officer
- Never work in poor lit areas
- Keep yourself well balanced and never overreach.
- Never work with material that is broken or unclean.
- Always consult a RAS officer before using any special equipment or setups.
- Never stand near danger zones or close to anyone operating equipment.

4.2.2 General Equipment Behavior:

- Always keep hands, arms, or legs out of the cutting path of equipment.
- Position your body out of harms way while operating any equipment.
- NEVER use faulty equipment that is subject to replacement.
- NEVER test the sharpness or temperature of a tool with an appendage of a body.
- Equipment will be used solely for its functions and are not to be considered toys.
- The appropriate use of tools for a given action must be considered in order to avoid error in equipment performance and protection.
- Only authorized members may use both the given equipment of the facility and equipment purchased by the organization.
- Equipment is not to be removed from the premises unless for club events or repairs.
- Properly use secure support surfaces while operating any equipment in order to ensure safety to both equipment and adjacent people.
- Always store or secure tools away from potential harm to yourself, other person(s), or the equipment itself.
- Cutting edges must be sharp and within operating conditions.
- Equipment should always be adjusted and calibrated before attempting a given task.
- Always consult a RAS officer before making adjustments or performing maintenance to equipment.
- Never force or apply uneven pressure while performing any tasks with equipment.

4.2.3 Cleanup and Awareness:

- Keep workspaces clear and organized.
- Keep isles clear of loose materials.
- Never use your hand or body parts to remove scraps or shavings away from equipment operating area.
- Remove any special attachments from equipment as well as reset both safety guards and standard settings to equipment.
- Don't leave spills or hazardous materials unattended.
- All equipment and tools will be returned to their designated storage area(s)/container(s).
- Maintain cleanliness of equipment to insure equipment functions properly.

4.2.4 Clothing Standards and PPE (Personal Protective Equipment):

- Always use personal protective equipment while operating any equipment.
- Complete coverage of feet must be worn.
- Hair should be secured with proper hair accessories.
- Jewelry must be removed before using any equipment.
- No baggy clothing will be worn while using equipment.
- Pants must be worn while using equipment..
- Shirts should be tucked in and long sleeves neatly rolled up.
- Do not wear gloves while operating equipment unless handling rough materials.
- Wear ear protection while around working around loud equipment.
- Use proper ventilation and wear masks to avoid breathing in harmful material debris.

4.2.5 Shop Maintenance:

- If you are not certain on cleaning procedures or cannot identify spilled substances, notify a RAS officer immediately.
- Always know location of fire extinguishers and how to use them.
- Always keep cabinet doors and drawers closed.
- If you disconnect power to a machine at the circuit breaker, use a lock out system or put up a sign: “Don’t Connect.”

4.2.6 Chemical Use and Storage:

- Chemicals include but are not limited to:
 - Potassium nitrate, ammonium, perchlorate, ammonium nitrate and potassium chloride, liquid oxygen, oxidizers, lithium, fluorine, methane, water, etc.
- All chemicals must be properly secured and stored when not in use.
- Any chemicals with noxious and flammable fumes must remain in airtight containers until directly in use.
- All flammable materials must be properly stored within given fire cabinets.
- While handling any dangerous fumes proper use of the fume hood, masks, goggles, lab coat, and gloves must be enforced.
- Chemical expiration’s must be documented and properly disposed of.
- Disposal of chemicals must be done properly and safely.
- Chemicals must be properly and eligibly labeled.

4.2.7 Materials:

- Materials include but are not limited to:
 - PVC pipe, wood, aluminum, steel, carbon fiber, polyethylene, G10 blue tube, polyurethane, polystyrene, various plastics and foams, ABS plastic, black powder, Epoxy, etc.

4.2.8 Hand Tools:

- Tools include but are not limited to:
 - Non-powered equipment such as: screwdrivers, pliers, hammers, etc.
- Hand tools are to be used in a safe manner at all times and should never be used outside of their designed purpose.
- Proper maintenance and replacement of hand tools should be exercised by all RAS members.

4.2.9 Power Tools:

- Tools include but are not limited to:
 - Table saw, Band saw, power drill, drill press, routing tools, sander, jig saw, circular saw, lathe, etc.
- Electric Power tools must be grounded or double insulated to prevent electric shock. If equipment does not meet that standard, it will not be used.
- Re-assure power tool as been turned off before connecting to a power source to avoid any unscripted equipment actions.
- Always make sure equipment has been turned off and unplugged before any adjustments or maintenance is performed.
- Always wait for machine to reach operating position/speed before use.
- Unplug or turnoff any equipment not being used

4.2.10 Specialized Machine and Equipment:

- Policies and procedures for any heavy equipment not listed above will be added under this given section as the need arises.

**Failure to adhere to the policies listed above will result in being given a warning appropriate to the offense. Repeated offenses will prompt a suspension and possible removal from construction activities*

Appendix D – Material Safety Data Sheets

Adjustable Density Expanding Foam

(See backside of this sheet for foam density adjustment)



WARNING: Do not burn or hotwire cut this or any urethane based foam product because toxic fumes will be released.

Encapsulate your pin joints with PML Adjustable Density Expanding Foam instead of using structural epoxy filler for a quick, strong and easier to form bond. Our special lightweight foams designed to resist the heat of a motor causing them to melt or other flame products to heat it or deteriorate.

If you have never used Adjustable Density Expanding Foam, we recommend that you start with a small batch and adjust it to its pinning capabilities. A full cup of foam is 100ml and how much is expanded? Once you've got the foam until it's fully expanded because you can easily run the cork around.

* Expandable liquid foam will not readily pour into cavities smaller than 1/8" wide.

When mounting motor mount without air frame, do not glue lower connecting ring to back for faster removal. Use tape tabs on connecting ring to hold it in place.

Lock film to motor table using epoxy. Apply an epoxy fillet to both sides of each pin. Be sure you seal all gaps between pin and slot.

Be sure all gaps in connecting ring are sealed with epoxy.

Once fully cured and pinned, cap off excess foam with black wax blade.

Pin it so you can see the foam. Release the end of the airframe until there is clearance for the connecting ring.

Mix a 1 pint batch of foam (approximately 400ml) vigorously for 30 seconds. Pour mixture into glass between motor mounting ring and airframe in circular motion. Allow each batch of foam to expand, cure, and cool before applying the next batch. Be sure you seal any gaps in the foam with foam.

Now epoxy the connecting ring in place.

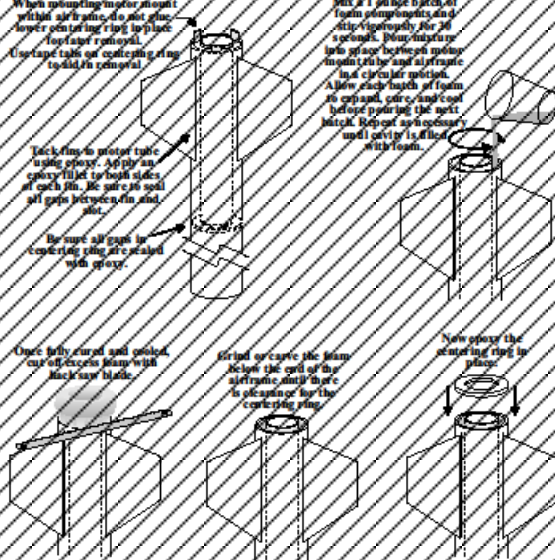

Public Missile, Ltd. Adjustable Density Expanding Foam

By combining equal parts of A and B, the foam expands to about 10 times its original liquid volume. The result is a 6 lb density (per cubic foot) rigid foam that is extremely strong and still relatively light weight. This is perfect for filling air and space where the highest strength is required and weight is not a pin point. However, as the volume increases, it loses strength. Strength reduction may be desirable. When the purpose of filling, ducting, or insulation is to insulate and additional air loss will factor in large volumes, weight may be the primary concern.

Either that, or several batches of foam densities. It is much easier to lower the density of a high density foam as needed. This type of adjustable foam is highly reactive to small amounts of water. Even the humidity in the air can slightly alter the expansion ratio. The primary method of adjusting the foam is, the higher the expansion ratio, the more likely adding small amounts of water to the mix will, we can adjust the expansion ratio.

After other methods of compression are available, 2 parts liquid foam expands to about 20 times original volume depending on the size of the batch. The 20:1 ratio is a lowest density and strength. It should be adjusted down.

Our new Adjustable Density Foam starts as a denser foam that can easily be adjusted using just a few drops of water.

Below is a photograph showing the results of adding various amounts of water to the mix of foam. The difference of just adding one drop of water is dramatic. Keep in mind that if you double the batch size, you will need to double the water amount to achieve the same expansion ratio. A little experimentation is highly recommended before actual use in your project.

When using that cubic 2.0oz expansion foam in a cavity with top markings, you will have just 30-45 minutes to get and secure the pin. Most often lets lets us add the water to Part A before adding Part B to save time.

Do not exceed 5 drops of water per 40ml total batch size. The foam may expand drastically and lose many of its strength and void filling characteristics or simply collapse. The first indications that you are near the limit is an abundance of large bubbles in the foam.

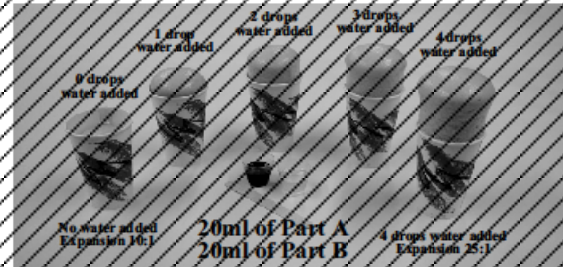

Here are a few examples of what we consider small and large volumes:

...When doing a pin on a 2.0oz expansion foam on a 2.1" airframe with a 1/8" motor mount, this would be considered a small volume so a higher density may be optimum.

...When doing a pin on a 2.0oz expansion foam on a 2.5" airframe with a 1/8" motor mount, this would be considered a medium/large volume so a lower density may be optimum.

...When doing a pin on a 2.0oz expansion foam on a 6.0" airframe with a 1/8" motor mount, this would be considered a large volume so the lowest density mix would be optimum. The same would hold true for filling applications. Even the lowest density foam will greatly strengthen any location.

Since a fair amount of heat is generated during the expansion and curing process, it is highly recommended that you fill large cavities with multiple smaller batches rather than one large batch. Allow each batch to expand, cure, and cool before adding the next batch.



AeroTech Division, RCS Rocket Motor Components, Inc.

Safety Data Sheet

Prepared in accordance with 29 CFR § 1910.1200 (g)

Section 1. Identification

Product identifier: AeroTech-branded Model rocket motor, high power rocket motor, hobby rocket motor, composite rocket motor, rocket motor kit, rocket motor reloading kit with the trade names White Lightning™, Blue Thunder™, Black Jack™, Black Max™, Redline™, Warp-9™, Mojave Green™, Metalstorm™, Metalstorm DM™ or Propellant X™.

Manufacturer: RCS Rocket Motor Components, Inc., 2113 W 850 N, Cedar City, UT 84721, 435-865-7100, emergency response number: Infotrac (352) 323-3500

Recommended use: Propulsion for hobby rockets.

Section 2. Hazard Identification

Hazard classification: Explosive 1.4S (under 30 grams per motor or propellant grain) and explosive 1.4C (30 to 62.5 grams per motor or propellant grain).

Signal word: Flammable

Hazard statement: Caution: Rocket motors and reload kits are flammable; rocket motors may become propulsive in a fire. All propellants give off varying amounts of Hydrogen Chloride and Carbon Monoxide gas when burned, Mojave Green propellant also produces Barium Chloride.

Pictograms:



Precautionary Statement: Do not smoke near rocket motors and reload kits and keep away from open flames and other heat sources.

Description of any hazards not otherwise classified: N/A

Unknown toxicity statement: N/A



Material Safety Data Sheet (MSDS-BP)

PRODUCT IDENTIFICATION	
Product Name	BLACK POWDER
Trade Names and Synonyms	N/A
Manufacturer/Distributor	GOEX, Inc. (Doyline, LA) & various international sources
Transportation Emergency	800-255-3924 (24 hrs — CHEM - TEL)

PREVENTION OF ACCIDENTS IN THE USE OF EXPLOSIVES

The prevention of accidents in the use of explosives is a result of careful planning and observance of the best known practices. The explosives user must remember that he is dealing with a powerful force and that various devices and methods have been developed to assist him in directing this force. He should realize that this force, if misdirected, may either kill or injure both him and his fellow workers.

WARNING

All explosives are dangerous and must be carefully handled and used following approved safety procedures either by or under the direction of competent, experienced persons in accordance with all applicable federal, state, and local laws, regulations, or ordinances. If you have any questions or doubts as to how to use any explosive product, **DO NOT USE IT** before consulting with your supervisor, or the manufacturer, if you do not have a supervisor. If your supervisor has any questions or doubts, he should consult the manufacturer before use.



Pro150 Rocket Motor Reload Kit SAFETY DATA SHEET

Page: 1 of 9
Version: 2.01 / EN
Rev. Date: 2017-03-23

1.0 PRODUCT / COMPANY IDENTIFICATION

1.1 Product Identifier

Product Name: Pro150 Rocket Motor Reload Kit

Synonyms: Rocket Motor, Hobby Rocket Motor, HPR Reload Kit, Solid Rocket Fuel

Part Numbers: Reload kit: P150R-Y-#G-XX
Where: Y = reload type (A = adjustable delay, C = C-slot)
= number of grains, &
XX = propellant type

1.2 Relevant Identified Uses

Product Use: Solid fuel motor for propelling rockets

1.3 Details of the Supplier of the SDS

Manufacturer / Supplier: Cesaroni Technology Inc.
P.O. Box 246
2561 Stouffville Rd.
Gormley, Ont.
Canada L0H 1G0
E-mail: res@csaroni.com

1.4 Emergency Telephone Numbers

Telephone Numbers:

Product Information: Tel: +1-905-887-2370 Fax: +1-905-887-2375

24 Hour Emergency Telephone Number: Tel: +1-613-996-6666 (CANUTEC)

2.0 HAZARDS IDENTIFICATION

2.1 Classification

Classification: Explosive Article – Division 1.3 (UN GHS – ST-SG-AC10-30-Rev5e)
(WHMIS 2015 – Canada, HazCom 2012 – USA, Regulation (EC) No. 1272/2008 (CLP) – EU, 67/548/EEC or 1999/45/EC – EU)

2.2 Label Elements

Signal Word: Danger **GHS Pictogram:**



Hazard Statement: H203 Explosive; Fire, Blast or Projection Hazard

Precautionary Statements

P210 Keep away from heat/sparks/open flames/hot surfaces. No smoking

P250 Do not subject to grinding/shock/friction.

P370+P380 In case of fire: Evacuate Area.

P372 Explosion risk in case of fire.

P373 DO NOT fight fire when fire reaches explosives.

P401 Store in accordance with local/regional/national regulations.

P501 Dispose of in accordance with local/regional/national regulations.

2.3 Other Hazards

Emergency Overview:

These articles contain cylinders of ammonium perchlorate composite propellant, encased in inert plastic parts. The SRM 3.0 rocket motors are classified as explosives, and may cause serious injury, including death if used improperly. All explosives are dangerous and must be handled carefully and used following approved safety

MATERIAL SAFETY DATA SHEET

Acculam™ Epoxyglas



Accurate Plastics, Inc.
18 Morris Place
Yonkers, New York 10705-1929
Phone (914) 476-0700
FAX (914) 476-0527
www.accumlam.com

Section 1. Chemical Product and Company Identification

<i>Product name</i> Acculam™ Epoxyglas	<i>Trade Name</i> NEMA Grades G10, G11, FR4, FR 5
<i>Manufacturer</i> Accurate Plastics, Inc. 18 Morris Place Yonkers, NY 10705-1929	<i>IN CASE OF EMERGENCY:</i> Tel: 914-476-0700 Chemtrec:
<i>Date of Preparation:</i> 11/29/07	<i>Replaces:</i> 10/20/04
<i>Preparers Name</i> KJ Soltys	

Section 2. Composition, Information on Ingredients

Component Information		Exposure Limits	
Chemical Name	CAS #	TLV, TWA ACGIH	OSHA PEL, TWA
Fiberglass	65997-17-3	10 mg/m ³ (dust)	15 mg/m ³ (total dust) 5 mg/m ³ (respirable)
Epoxy Resin	25036-25-3	N/A	N/A

Dust generated during grinding, cutting, or drilling fiber glass reinforced plastic contains respirable fiber shaped plastic (organic) particles which has an OSHA PEL of 5 mg/m³ and nonrespirable fibrous glass dust regulated by OSHA as noted above. Bromine may be an integral part of the polymer matrices of some laminate grades.

N/A = Not Applicable

Section 3. Hazards Identification

Dust generated during machining and grinding operations may cause skin or eye irritation. Fumes from thermal decomposition or burning may irritate eyes, nose, and throat. Minimize operator exposure to dust and fumes.	
Routes of Exposure	Symptoms
Inhalation	Inhalation of dust during machining and grinding operations may cause moderate irritation to mucous membranes and coughing.
Skin	Contact with dust may cause moderate irritation.
Eyes	Contact with dust may cause moderate eye irritation, itching and redness.
Ingestion	Not determined
Cancer	OSHA: N/A IARC: N/A NTP: N/A
Chronic	Dust generated during grinding, cutting, or drilling fiber glass reinforced plastic produces respirable fiber shaped plastic (organic) particles whose concentration increases proportionally with dust concentration. These particles are not classified as carcinogenic by IARC or NTP. However, prolonged inhalation of dust can produce lung disease.



CARBON COMPOSITES, INC.

MATERIAL SAFETY DATA SHEET

SECTION 1 - PRODUCT IDENTIFICATION

Manufacture's Name
Carbon Composites, Inc.

Emergency Telephone No.
(978) 840-0707

Address
12 Jytek Park
Leominster, MA 01453-5932

Telephone No. for Information
(978) 840-0707

Product Name
Rigidized Carbon Felt Insulation
Carbon Fiber Composite

Date Prepared
January, 2002
Updated December 4, 2009

Synonyms
Carbon/Graphite Felt Insulation
Graphite Foil Laminate
Carbon Fiber Composite Laminate, CFC, Carbon/Carbon

SECTION 2 - INGREDIENTS (INERT & HAZARDOUS)

Composition	%	CAS #	OSHA PEL	ACGIH TLV
Carbon/Synthetic Graphite	99.9+	7440-44-0 7782-42-5	15 mg/m ³	10 mg/m ³

SECTION 3 - PHYSICAL / CHEMICAL DATA

Boiling Point	N/A	Melting Point	N/A
Evaporation Rate (Butyl Acetate = 1)	N/A	Solubility in Water	Negligible
Vapor Pressure (mm Hg)	N/A	Vapor Density (Air = 1)	N/A
Specific Gravity (H ₂ O = 1)	0.13 – 0.25	Volatiles by Weight	Negligible @ RT
Carbon Fiber Composite	1.3 – 1.5 g/cc		

Appearance and Odor
Gray solid laminate, Gray-black fibrous felt; negligible odor

SECTION 4 - FIRE AND EXPLOSION HAZARD DATA

Flash Point	N/A	Flammable Limits	LEL – N/A; UEL – N/A
Extinguishing Media	Water, CO ₂ , Sand	Extinguishing Media to Avoid	N/A

Special Fire Fighting Procedures N/A, Difficult to Ignite

Unusual Fire and Explosion Data

Graphite and carbon dusts are normally not explosive, but these may weakly contribute if the event is initiated by another explosive dust or gas. Graphite and carbon dusts are electrically conductive; dust accumulations may cause electrical short circuits or other electrical malfunctions.

Innofil^{3D} make anything!



MATERIAL SAFETY DATA SHEET
according to Regulation (EU) No. 1907/2006

Innofil3D ABS

1. IDENTIFICATION OF THE SUBSTANCE/PREPARATION AND OF THE COMPANY / UNDERTAKING

Product information

Trade name : Innofil3D ABS

Chemical name : Acrylonitrile Butadiene Styrene

Chemical family : Thermoplastic Copolymers

Use : Monofilament for 3D printing

Company : Innofil3D BV.
Eerste Bokslotweg 17
7821 AT Emmen

Telephone : +31 (0)591 69 2117

Telefax : +31 (0)591 69 3456

2. HAZARDS IDENTIFICATION

- a. Classification of substance or mixture**
Classification – REGULATION (EC) No 1272/2008
This product is not classified as dangerous according to EC criteria.
Classification according to EU Directive 67/548/EEC or 1999/45/EC
This product is not classified as dangerous according to EC criteria.
- b. Label elements**
Labelling – REGULATION (EC) No 1272/2008
This product is not classified as dangerous according to EC criteria.
- c. Other hazards**
No information available



DATA SHEET: G5000 HIGH STRENGTH EPOXY

Description: G5000 is a two component filled epoxy with high strength bonds for joining fiberglass and carbon fiber composites with extremely high shear strengths. It also has excellent adhesion to metals, plastics, woods, and ceramics as well. Cures to a very high strength bond that is also non-brittle to eliminate flexing cracks. Easy to mix 1 to 1 ratio by weight and volume. Mixes to a smooth creamy paste that when applied eliminates drips, sagging, or runoff. Does not require any thickening or strength additives as epoxy is ready to use as supplied. The adhesive cures relatively quickly and can be handled within a few hours. Cures to an easy to paint off white color but pigment can be easily added to provide almost any color desired.

It has excellent mechanical properties, high shear and peel strength, great adhesion, good chemical and environmental resistance, good thermal shock resistance and very low shrinkage. It has low exotherm during cure for filling large mass voids.

Uses: Joining and bonded fiberglass, carbon fiber, composites, any where a high strength non-brittle bond is needed. Great for attaching composite rocket fins, bulk plates, nose cone hardware and especially for professional grade fin fillets.

Mixing and Cure Instructions:

Ratio by weight:	Resin	100	Hardener	100
Ratio by volume:	Resin	100	Hardener	100
Pot life (100 gram mass at 72°F)	=	30 to 40 minutes	ASTM D2471	
Handling time	=	3 to 4 hours		
Full cure	=	6 to 8 hours		

Physical Properties (@ 72°F/22°C):

Color	Off white but can be pigmented to black or any color.		
Shore "D" hardness	85	ASTM D2240	
Viscosity Resin	Paste		
Viscosity Hardener	Paste		
Viscosity Mixed	Paste		
Specific gravity, Resin	1.52		
Specific gravity, Hardener	1.48		
Specific gravity mixed	1.50		
Tensile strength	7,600 psi	ASTM D638	
Compression strength	14,800 psi	ASTM D695	
Elongation at break %	6.3%	ASTM D638	
Typical operating temperature	-50°F to 175°F		
Maximum use temperature	225°F (107°C)		
Deflection temperature	150°F (66°C)	ASTM D648	
Shelf Life	1-1/2 Years		

Notice: This information is presented to assist the user in determining whether our products are suitable for his intended use. The user assumes all risks and liability in connection therewith. No warranty or representation express or implied shall apply to these products. Seller's only obligation shall be to replace quantity of this product which has proven to not substantially comply with the data presented. Seller shall not be responsible for property loss or damage direct or consequential arising out of use of this product(s) or inability to use this product(s). See material safety data sheet before using.

Bibliography

Aerospaceweb.org | Ask Us - Rocket Nose Cones and Altitude,
www.aerospaceweb.org/question/aerodynamics/q0151.shtml.

Arduino Uno R3.” Elektor, www.elektor.com/arduino-uno-r3

Baker, Wilfred E., et al. Similarity methods in engineering dynamics: theory and practice of scale modeling. Revised ed., Elsevier, 1993.

Blue Tube 2.0.” Always Ready Rocketry, www.alwaysreadyrocketry.com/.

Components, Inc© Apogee. “Your Model Rocket Success Is Our Mission!” Model Rockets & How-To Rocketry Information, www.apogeerockets.com/.

“DMLS Design Guidelines.” DMLS Design Guidelines | Direct Metal Laser Sintering | Stratasys Direct, www.stratasysdirect.com/resources/design-guidelines/direct-metal-laser-sintering.

“G10 Material Properties.” MatWeb - The Online Materials Information Resource, MatWeb, www.matweb.com/search/datasheet.aspx?matguid=8337b2d050d44da1b8a9a5e61b0d5f85&ckc k=1.

Miele, Angelo. Applied mathematics in aerospace science and engineering: Plenum Press, 1994.

Murphy, Glenn. Similitude in engineering. Ronald Press Co., 1950.

Niskanen, Sampo. “Technical Documenttion.” OpenRocket - Documentation, 10 May 2013, openrocket.info/documentation.html.

Parkin, Charles M. *The Rocket Handbook for Amateurs; an Illustrated Guide to the Safe Construction, Testing, and Launching of Model Rockets*. J. Day Co., 1959.

PLA vs ABS: Filaments for 3D Printing Explained & Compared.” All3DP, 5 Jan. 2018, all3dp.com/pla-abs-3d-printer-filaments-compared/.

Raider Aerospace Society. Preliminary Design Review. Raider Aerospace Society, 2018, Preliminary Design Review.

“SparkFun Triple Axis Accelerometer Breakout - MMA8452Q (with Headers).” BOB-13926 - SparkFun Electronics, www.sparkfun.com/products/13926.

Sutton, George P. *Rocket propulsion elements: an introduction to the engineering of rockets*. 6th ed., A Wiley Interscience Publication, 1992.

Uroda, Frank R. ““We Have Epoxy for Most Rocket Building Applications. Our Adjustable Density Foam Is Excellent for Fin Root Potting.”” PML Rocket Epoxy and Foam, m.publicmissiles.com/adhesives.aspx.